

# DRAFT

## PRELIMINARY ENGINEERING REPORT

Florida Department of Transportation

Florida's Turnpike Enterprise

Poinciana Parkway Extension Connector Project Development and Environment (PD&E) Study

From CR 532 to North of I-4/SR 429 Interchange

Osceola and Polk Counties, Florida

Financial Management Number: 446581-1

ETDM Number: 14445

February 2023

The environmental review, consultation, and other actions required by applicable Federal environmental laws for this project are being, or have been, carried out by the Florida Department of Transportation (FDOT) pursuant to 23 U.S.C. §327 and a Memorandum of Understanding dated May 26, 2022, and executed by the Federal Highway Administration and FDOT.

# PROFESSIONAL ENGINEER CERTIFICATION

## PRELIMINARY ENGINEERING REPORT

Project: Poinciana Parkway Extension Connector Project Development and Environment  
(PD&E) Study from CR 532 to North of I-4/SR 429 Interchange

ETDM Number: 14445

Financial Project ID: 446581-1-22-01

Federal Aid Project Number: N/A

This preliminary engineering report contains engineering information that fulfills the purpose and need for the Poinciana Parkway Extension Connector Project Development & Environment Study from CR 532 to North of I-4/SR 429 Interchange in Osceola and Polk Counties, Florida. I acknowledge that the procedures and references used to develop the results contained in this report are standard to the professional practice of transportation engineering as applied through professional judgment and experience.

I hereby certify that I am a registered professional engineer in the State of Florida practicing with Kimley-Horn and Associates, Inc., and that I have prepared or approved the evaluation, findings, opinions, conclusions, or technical advice for this project.



# TABLE OF CONTENTS

<u>Section</u>	<u>Page Number</u>
1.0 PROJECT SUMMARY .....	1-1
1.1 PROJECT DESCRIPTION.....	1-1
1.2 PURPOSE & NEED.....	1-3
1.2.1 Primary Purpose and Need.....	1-3
1.2.2 Secondary Purpose and Need.....	1-4
1.3 COMMITMENTS.....	1-5
1.4 ALTERNATIVES ANALYSIS SUMMARY.....	1-6
1.5 DESCRIPTION OF PREFERRED ALTERNATIVE .....	1-7
1.6 LIST OF TECHNICAL DOCUMENTS.....	1-7
2.0 EXISTING CONDITIONS .....	2-1
2.1 ROADWAY .....	2-2
2.1.1 SR 429.....	2-2
2.1.2 I-4.....	2-4
2.1.3 CR 532.....	2-5
2.1.4 South Old Lake Wilson Road.....	2-5
2.1.5 Poinciana Parkway (SR 538).....	2-5
2.2 RIGHT-OF-WAY.....	2-6
2.3 ROADWAY CLASSIFICATION .....	2-6
2.4 ADJACENT LAND USE.....	2-7
2.5 ACCESS MANAGEMENT CLASSIFICATION .....	2-12
2.6 DESIGN AND POSTED SPEEDS.....	2-12
2.7 VERTICAL AND HORIZONTAL ALIGNMENT.....	2-13
2.8 PEDESTRIAN ACCOMMODATIONS.....	2-16
2.9 BICYCLE FACILITIES.....	2-16
2.10 TRANSIT FACILITIES.....	2-16
2.11 PAVEMENT CONDITION.....	2-16
2.12 TRAFFIC VOLUMES AND OPERATIONAL CONDITIONS.....	2-17
2.13 INTERSECTION LAYOUT AND TRAFFIC CONTROL.....	2-19
2.14 RAILROAD CROSSINGS.....	2-21

2.15	CRASH DATA AND SAFETY ANALYSIS .....	2-21
	2.15.1 <i>Crash Data Analysis</i> .....	2-21
	2.15.2 <i>Mainline and Interchange Crashes</i> .....	2-22
	2.15.3 <i>Intersection Crashes</i> .....	2-26
2.16	DRAINAGE.....	2-31
2.17	SOILS AND GEOTECHNICAL DATA.....	2-34
2.18	UTILITIES.....	2-36
	2.18.1 <i>Utility Coordination</i> .....	2-36
	2.18.2 <i>Existing Utility Facilities</i> .....	2-38
2.19	LIGHTING.....	2-39
2.20	SIGNS.....	2-40
2.21	AESTHETICS FEATURES.....	2-44
2.22	BRIDGES AND STRUCTURES.....	2-44
3.0	PROJECT DESIGN CONTROLS & CRITERIA.....	3-1
3.1	ROADWAY CONTEXT CLASSIFICATION.....	3-1
3.2	DESIGN CONTROL AND CRITERIA.....	3-1
4.0	ALTERNATIVES ANALYSIS.....	4-1
4.1	PREVIOUS PLANNING STUDIES.....	4-1
4.2	NO-BUILD (NO-ACTION) ALTERNATIVE .....	4-2
4.3	TRANSPORTATION SYSTEMS MANAGEMENT & OPERATIONS ALTERNATIVE (TSM&O).....	4-2
4.4	FUTURE CONDITIONS .....	4-2
4.5	BUILD ALTERNATIVE(S).....	4-3
	4.5.1 <i>Poinciana Parkway (SR 538) Typical Section</i> .....	4-9
	4.5.2 <i>SR 429 Typical Section</i> .....	4-9
	4.5.3 <i>I-4 Typical Section</i> .....	4-10
	4.5.4 <i>Poinciana Parkway (SR 538) at CR 532 Interchange</i> .....	4-11
	4.5.5 <i>Poinciana Parkway (SR 538)/I-4/SR 429 Interchange</i> .....	4-12
	4.5.6 <i>SR 429 at Sinclair Road Interchange</i> .....	4-15
	4.5.7 <i>Proposed Structures</i> .....	4-16
4.6	COMPARATIVE ALTERNATIVES EVALUATION.....	4-32
	4.6.1 <i>Geometric Characteristics</i> .....	4-34

4.6.2	<i>Utility Impacts</i> .....	4-34
4.6.3	<i>Drainage</i> .....	4-37
4.6.4	<i>Environmental Impacts</i> .....	4-37
4.6.5	<i>Stakeholder Input</i> .....	4-39
4.6.6	<i>Comparison of Advantages and Disadvantages</i> .....	4-40
4.7	SELECTION OF THE PREFERRED ALTERNATIVE.....	4-41
5.0	PROJECT COORDINATION & PUBLIC INVOLVEMENT.....	5-1
5.1	AGENCY COORDINATION.....	5-1
5.2	PUBLIC INVOLVEMENT.....	5-1
6.0	DESIGN FEATURES OF THE PREFERRED ALTERNATIVE.....	6-1
6.1	ENGINEERING DETAILS OF THE PREFERRED ALTERNATIVE.....	6-1
6.1.1	<i>Typical Sections</i> .....	6-1
6.1.2	<i>Bridges and Structures</i> .....	6-2
6.1.3	<i>Right-of-Way and Relocations</i> .....	6-13
6.1.4	<i>Horizontal and Vertical Geometry</i> .....	6-13
6.1.5	<i>Bicycle and Pedestrian Accommodations</i> .....	6-13
6.1.6	<i>Multi-Modal Accommodations</i> .....	6-13
6.1.7	<i>Access Management</i> .....	6-13
6.1.8	<i>Intersection and Interchange Concepts</i> .....	6-14
6.1.9	<i>Intelligent Transportation System and TSM&amp;O Strategies</i> .....	6-14
6.1.10	<i>Utilities</i> .....	6-14
6.1.11	<i>Drainage and Stormwater Management Facilities</i> .....	6-14
6.1.12	<i>Floodplain Analysis</i> .....	6-15
6.1.13	<i>Transportation Management Plan</i> .....	6-17
6.1.14	<i>Special Features</i> .....	6-19
6.1.15	<i>Design Variations and Design Exceptions</i> .....	6-19
6.1.16	<i>Cost Estimates</i> .....	6-19
6.2	SUMMARY OF ENVIRONMENTAL IMPACTS OF THE PREFERRED ALTERNATIVE.....	6-20
6.2.1	<i>Future Land Use</i> .....	6-20
6.2.2	<i>Section 4(f)</i> .....	6-20
6.2.3	<i>Cultural Resources</i> .....	6-20

6.2.4 *Wetlands*..... 6-21  
6.2.5 *Protected Species and Habitat*..... 6-21  
6.2.6 *Essential Fish Habitat* ..... 6-25  
6.2.7 *Highway Traffic Noise*..... 6-25  
6.2.8 *Contamination*..... 6-28

## LIST OF FIGURES

<u>Figure</u>	<u>Page Number</u>
Figure 1-1: Project Location Map.....	1-2
Figure 2-1: Study Area.....	2-1
Figure 2-2: Typical Section – Planned SR 429 .....	2-4
Figure 2-3: Typical Section – Planned I-4 BtU from CR 532 to SR 429.....	2-4
Figure 2-4: Typical Section – Planned CR 532.....	2-5
Figure 2-5: Typical Section – Planned Poinciana Parkway (SR 538).....	2-6
Figure 2-6: Existing Land Use .....	2-9
Figure 2-7: Major Developments .....	2-11
Figure 2-8: 2020 (Existing) Peak Hour Volumes .....	2-18
Figure 2-9: Existing Intersection Layout and Control .....	2-20
Figure 2-10: Crash Locations along the SR 429 and I-4 Mainline.....	2-23
Figure 2-11: Crash Data Summary – SR 429 Mainline from MP 0 to MP 2.....	2-24
Figure 2-12: Crash Data Summary – I-4 Mainline.....	2-25
Figure 2-13: Crash Data Summary – SR 429 at Sinclair Road Ramps.....	2-26
Figure 2-14: Crash Locations along CR 532 and US 17/US 92.....	2-27
Figure 2-15: Crash Data Summary – CR 532 & Lake Wilson Road Intersection.....	2-28
Figure 2-16: Crash Data Summary – CR 532 & US 17/92 Intersection.....	2-29
Figure 2-17: Crash Data Summary – CR 532 Mid-Block.....	2-30
Figure 2-18: Floodplain Map.....	2-33
Figure 2-19: Soils Map .....	2-35
Figure 2-18: Overhead Traffic Signs.....	2-41
Figure 4-1A: Alternative 1 (1 of 2).....	4-5
Figure 4-1B: Alternative 1 (2 of 2).....	4-6
Figure 4-2A: Alternative 2 (1 of 2).....	4-7
Figure 4-2B: Alternative 2 (2 of 2).....	4-8
Figure 4-3: Poinciana Parkway (SR 538) Proposed Six-Lane Typical Section .....	4-9
Figure 4-4: SR 429 Proposed Typical Section.....	4-10
Figure 4-5: I-4 Proposed Typical Section .....	4-10

Figure 4-6: Alternative 1 through the Poinciana Parkway (SR 538)/I-4/SR 429 Interchange.....	4-13
Figure 4-7: Alternative 2 through the Poinciana Parkway (SR 538)/I-4/SR 429 Interchange.....	4-14
Figure 4-8: Proposed System-to-System Ramp Designations.....	4-15
Figure 4-9: Typical Section for Ramp A1.....	4-17
Figure 4-10: Typical Section for Ramp A2.....	4-17
Figure 4-11: Typical Section for Ramp A3.....	4-18
Figure 4-12: Typical Section for Ramp B1.....	4-18
Figure 4-13: Typical Section for Ramp B2.....	4-19
Figure 4-14: Typical Section for Ramp B3.....	4-19
Figure 4-15: Typical Section for Ramp C1.....	4-20
Figure 4-16: Typical Section for Ramp C2.....	4-20
Figure 4-17: Typical Section for Ramp C3.....	4-21
Figure 4-18: Typical Section for Ramp D1.....	4-21
Figure 4-19: Typical Section for Ramp D2.....	4-22
Figure 4-20: Typical Section for Northbound and Southbound Poinciana Parkway (SR 538)....	4-22
Figure 4-21: Typical Section for Ramp A1.....	4-24
Figure 4-22: Typical Section for Ramp A2.....	4-24
Figure 4-23: Typical Section for Ramp A3.....	4-25
Figure 4-24: Typical Section for Ramp B1.....	4-25
Figure 4-25: Typical Section for Ramp B2.....	4-26
Figure 4-26: Typical Section for Ramp B3.....	4-26
Figure 4-27: Typical Section for Ramp C1.....	4-27
Figure 4-28: Typical Section for Ramp C2.....	4-27
Figure 4-29: Typical Section for Ramp C3.....	4-28
Figure 4-30: Typical Section for Ramp D1.....	4-28
Figure 4-31: Typical Section for Ramp D2.....	4-29
Figure 4-32: Typical Section for Northbound and Southbound Poinciana Parkway (SR 538)....	4-29
Figure 4-33: Typical Section for SR 429 over CR 532.....	4-30
Figure 4-34: Typical Section for Sinclair Road.....	4-30
Figure 4-35: Typical Section for SR 429 over Sand Hill Road.....	4-31
Figure 4-36: Potential Utility Impacts.....	4-36

Figure 6-1: Bridge Typical Section for Poinciana Parkway (SR 538) over I-4.....6-2

Figure 6-2: Bridge Typical Section for Poinciana Parkway (SR 538) over Davenport Creek .....6-3

Figure 6-3: Typical Section for Ramp A1.....6-3

Figure 6-4: Typical Section for Ramp A2.....6-4

Figure 6-5: Typical Section for Ramp A3.....6-5

Figure 6-6: Typical Section for Ramp B1 .....6-5

Figure 6-7: Typical Section for Ramp B2 .....6-6

Figure 6-8: Typical Section for Ramp B3 .....6-7

Figure 6-9: Typical Section for Ramp C1 .....6-7

Figure 6-10: Typical Section for Ramp C2.....6-8

Figure 6-11: Typical Section for Ramp C3.....6-9

Figure 6-12: Typical Section for Ramp D1 over Westbound I-4.....6-9

Figure 6-13: Typical Section for Ramp D1 over Pond .....6-10

Figure 6-14: Typical Section for Ramp D2 over I-4.....6-10

Figure 6-15: Typical Section for Ramp D2 over Davenport Creek.....6-11

Figure 6-16: Typical Section for Poinciana Parkway (SR 538) over CR 532.....6-11

Figure 6-17: Typical Section for SR 429 over Sand Hill Road.....6-12

Figure 6-18: Noise Sensitive Sites.....6-27

## LIST OF TABLES

<u>Table</u>	<u>Page Number</u>
Table 2-1: Roadway Number of Lanes.....	2-2
Table 2-2: Existing Interchanges.....	2-3
Table 2-3: Existing Roadway Right-of-Way.....	2-6
Table 2-4: Roadway Functional Classification .....	2-7
Table 2-5: Study Area FLUCFCS Summary and Acreage .....	2-8
Table 2-6: Access Management Classification .....	2-12
Table 2-7: Design and Posted Speed Limits .....	2-12
Table 2-8: Existing Horizontal Alignment and Criteria.....	2-14
Table 2-9: Existing Vertical Alignment and Criteria.....	2-14
Table 2-10: Pedestrian Facilities .....	2-16
Table 2-11: Bicycle Facilities.....	2-16
Table 2-12: 2020 (Existing) Annual Average Daily Traffic .....	2-17
Table 2-13: 2020 (Existing) AM/PM Peak Hour Intersection Level of Service/Delay (s/veh).....	2-19
Table 2-14: I-4 and SR 429 Corridor Crashes and Severity by Year .....	2-21
Table 2-15: Number of Crashes by Location and Year .....	2-22
Table 2-16: Crash Rates and Safety Ratios for 2014 through 2018 .....	2-31
Table 2-17: Utility Contact Information.....	2-37
Table 2-18: Existing Lighting.....	2-40
Table 2-19: Existing Bridge Structures .....	2-46
Table 2-20: Existing Box Culverts .....	2-46
Table 3-1: Design Control Criteria .....	3-1
Table 4-1: CAP-X Analysis Summary – Poinciana Parkway (SR 538) at CR 532.....	4-11
Table 4-2: CAP-X Analysis – Poinciana Parkway (SR 538) at CR 532 Northbound Ramp.....	4-11
Table 4-3: CAP-X Analysis – Poinciana Parkway (SR 538) at CR 532 Southbound Ramp.....	4-12
Table 4-4: CAP-X Analysis Summary – SR 429 at Sinclair Road .....	4-15
Table 4-5: CAP-X Analysis Summary – SR 429 at Sinclair Ramps.....	4-16
Table 4-6: Evaluation Matrix .....	4-33
Table 4-7: Potential Utility Conflicts.....	4-35



Table 4-8: Comparison of Advantages and Disadvantages ..... 4-40

Table 6-1: Anticipated Right-of-Way for Preferred Ponds..... 6-15

Table 6-2: Floodplain Encroachments..... 6-16

Table 6-3: Cost Estimate for the Preferred Alternative ..... 6-20

Table 6-4: Federal Protected Species Effect Determinations..... 6-23

Table 6-5: State Protected Species Effect Determinations ..... 6-24

Table 6-6: Potentially Feasible and Reasonable Noise Barrier Evaluation Summary..... 6-26

Table 6-7: Summary of Potential Contamination Sources..... 6-28

## LIST OF APPENDICES

### Appendix

Appendix A: Value Engineering Resolution Memorandum

Appendix B: Typical Sections for the Preferred Alternative

Appendix C: Preferred Alternative Concept

Appendix D: Vertical Profile Sheets for the Preferred Alternative

Appendix E: Long Range Estimates (LRE) Summary for the Preferred Alternative

## 1.0 PROJECT SUMMARY

### 1.1 Project Description

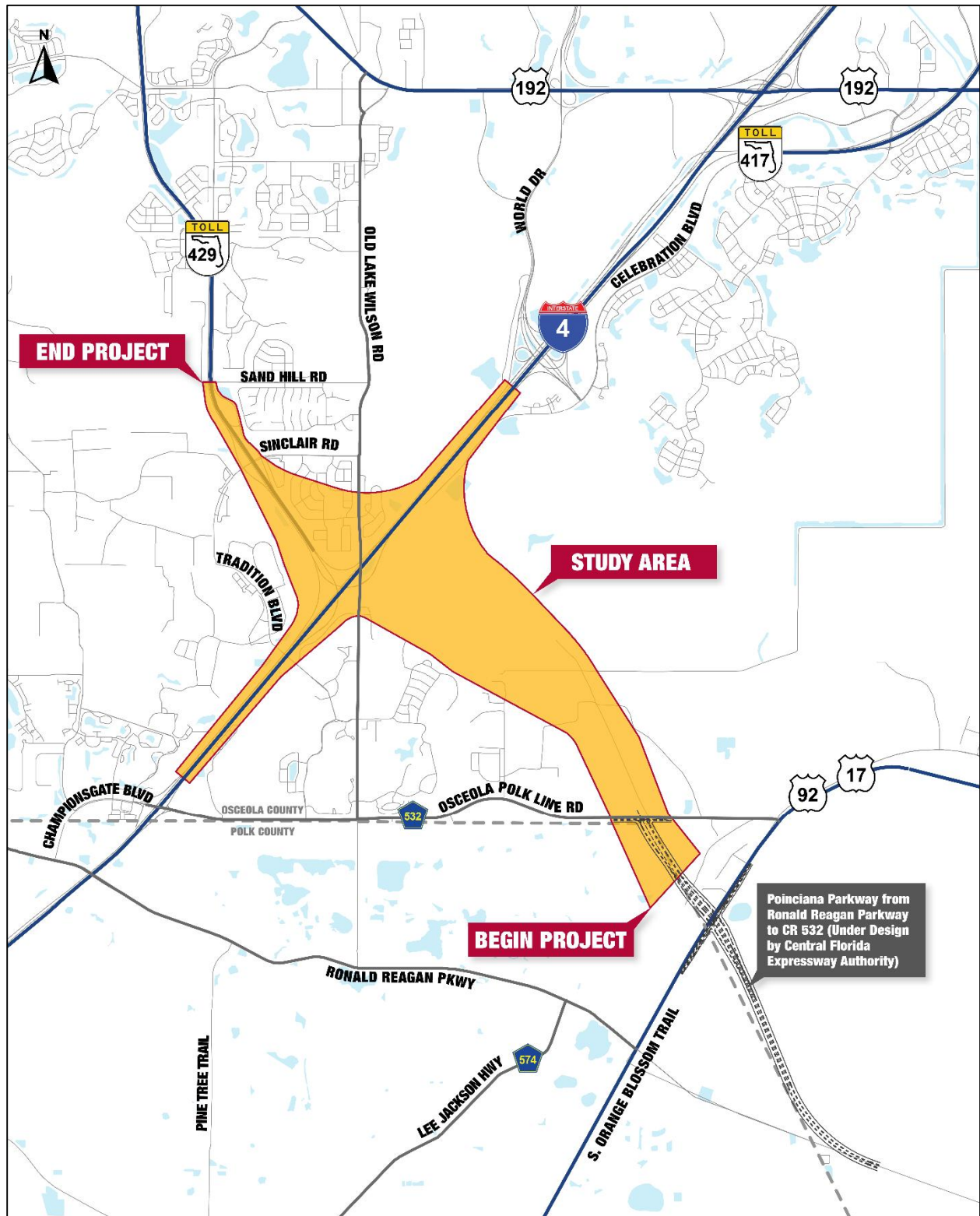
The project involves extending Poinciana Parkway (SR 538) from County Road 532 (CR 532) to the Interstate 4 (I-4)/State Road 429 (SR 429) interchange, modifying the I-4/SR 429 interchange to accommodate the Poinciana Parkway (SR 538) connection, and increasing capacity of the segment of SR 429 from the I-4/SR 429 interchange to the SR 429/Sinclair Road interchange. The total project length is 4.97 miles.

Poinciana Parkway (SR 538) is a section of a future, six lane limited access toll facility, often referred to as the "Southern Beltway". The Southern Beltway would provide a regional, limited access facility that connects I-4 on the west to the interchange of Boggy Creek Road/SR 417 on the east, a distance of approximately 50 miles. The westernmost portion of the Southern Beltway is referred to as the Poinciana Parkway.

The existing interchange at I-4 and SR 429 is a full access interchange with no connection to the south. Currently, I-4 provides six lanes (three lanes in each direction) and SR 429 provides four lanes (two lanes in each direction).

The study area (see Figure 1-1), which includes portions of unincorporated Osceola and Polk Counties, is comprised of residential land uses, the 2,226-acre Reunion Resort, and conservation lands under the jurisdiction of the Reedy Creek Improvement District (RCID). Although there are no municipalities in the study area, the project includes the unincorporated areas of Loughman and Poinciana. There are also numerous undeveloped parcels with residential and planned development future land use designations, wetland systems, and overhead and underground utility corridors. CR 532 follows the county line between Polk County on the south and Osceola County on the north.

Figure 1-1: Project Location Map



## 1.2 Purpose & Need

The purpose of this project is to complete the missing link in the Poinciana Parkway (SR 538) between the planned terminus at County Road 532 (CR 532) to the Interstate 4 (I-4)/State Road 429 (SR 429) interchange. The project will also address future congestion on SR 429 from the I-4/SR 429 interchange to the SR 429/Sinclair Road interchange.

### 1.2.1 Primary Purpose and Need

#### 1.2.1.1 Systems Linkage

The Poinciana Parkway (SR 538) currently terminates at the intersection of US 17/92 and Ronald Reagan Parkway/County Road 54 (CR 54). As part of a separate effort, the Poinciana Parkway (SR 538) is being extended approximately 1.75 miles north to CR 532. Therefore, this project would complete the remaining 2.5-mile gap in the Poinciana Parkway (SR 538) between CR 532 and I-4/SR 429.

Previous travel demand forecasting efforts have estimated that approximately 50,000 to 60,000 vehicles per day are projected to use the Poinciana Parkway (SR 538) between Poinciana and the I-4/SR 429 interchange by year 2050.

In the No-Build condition, once the separate in-progress Poinciana Parkway (SR 538) effort is completed, to reach I-4 from Poinciana, motorists would therefore be required to exit the limited-access Poinciana Parkway (SR 538) and travel approximately 2.5 miles on CR 532, an urban minor arterial. In addition, to access SR 429, motorists would then be required to travel an additional 1.5 miles on a congested portion of I-4. Therefore, motorists would travel approximately four miles total to reach SR 429. This would add a substantial number of trips to I-4, CR 532 and other local roadways, thereby increasing travel times and adding congestion on both I-4 and the local roadway network.

Finally, this approximately two-mile gap in the Poinciana Parkway (SR 538) would create a disjointed section in the overall 50-mile Southern Beltway, a limited access facility, intended to connect to the Western Beltway/SR 429, providing a regional beltway around Metro Orlando.

#### 1.2.1.2 Transportation Demand

Based on travel demand forecasts presented in the Florida's Turnpike Enterprise's 2019 Traffic Trends Report, in the No-Build condition, without capacity improvements, the segment of SR 429 between I-4 and Sinclair Road will not meet level of service (LOS) standards (LOS C) by the year 2030. Further congestion would be anticipated between 2030 and 2050, the project's design year. LOS will be used as a primary measure of effectiveness. The LOS target for state roads during peak travel hours is "D" in urban areas, per the State Highway System Policy No. 000-525-006c. The Build Alternative would be designed to meet the established LOS D target to the greatest extent practicable in Design Year 2050.

### 1.2.1.3 Project Status

The Poinciana Parkway (SR 538) was initially developed by the Osceola County Expressway Authority (OCX). OCX was formed by legislation in 2010 and ultimately incorporated into the Central Florida Expressway Authority (CFX) in 2014. This project was recommended as part of the OCX 2040 Master Plan, which planned a new limited access facility from I-4 in Osceola County to the Boggy Creek Road/SR 417 interchange in Orange County. The projects in the OCX Master Plan have since been adopted by CFX, except for this approximately 4.5-mile project, known as the I-4/Poinciana Connector.

The project, as currently planned, is listed in the MetroPlan Orlando 2045 Metropolitan Transportation Plan (i.e., Long Range Transportation Plan) Cost Feasible Plan (adopted December 9, 2020, revised March 9, 2022) as an FTE cost feasible project (MTP ID # 1055). The Project Development and Environment (PD&E) study for this project is included in the current Metroplan Orlando Transportation Improvement Program (TIP) for Fiscal Years (FY) 2021/22 – 2025/26 (adopted July 7, 2021, revised February 9, 2022) and the current State Transportation Improvement Program (STIP) for FY 2022/23 – 2025/26.

### 1.2.2 Secondary Purpose and Need

Additional needs for the project were identified through the PD&E Study process and are described below.

#### 1.2.2.1 Safety

The Poinciana Parkway Extension Connector (PPEC) is needed to enhance safety. Between 2014 and 2018, there were 1,147 crashes along I-4 and 42 crashes along SR 429 within the study limits. The estimated economic crash cost for these crashes is about \$171 million dollars along I-4 and \$14 million along SR 429 over the five years. Six fatal crashes were reported along the I-4 corridor. One fatal crash was reported along SR 429 within the study limits.

Between 2014 and 2018, there were 128 crashes along US 17/92 and 478 crashes along CR 532 within the study limits. There was one fatal crash that occurred along US 17/92. Two fatal crashes were reported within the study limits of CR 532. The estimated economic crash cost is about \$25 million dollars for US 17/92 and \$64 million for CR 532 over the five years. Congestion is a major contributing factor to crashes. In the No-Build condition, congestion would likely continue to rise leading to an increase in crashes.

### 1.2.2.2 Travel Times and Reliability

The extension of Poinciana Parkway (SR 538) is needed to improve travel time reliability. The current lack of a direct connection from Poinciana Parkway (SR 538) to I-4 and SR 429 results in significant congestion on I-4, CR 532, and S. Old Lake Wilson Road which produces significant delays and reduces travel time reliability. The existing travel pattern requires travelers from the south to take CR 532 to get to either I-4 or SR 429. The PPEC will create a more direct connection between Poinciana Parkway (SR 538), I-4, and SR 429, and relieve the section of I-4 between CR 532 and SR 429. The proposed improvements are expected to cut travel distances in half for PPEC users and reduce travel times substantially for these users, as well as those on I-4 during peak periods.

### 1.2.2.3 Emergency Response

Currently, Poinciana has a population of approximately 70,000 people. This high population combined with limited roads accessing Poinciana results in significant congestion on local roadways. The PPEC will increase access to Poinciana and provide improved emergency response times and improved evacuation routes.

## 1.3 Commitments

1. FDOT will re-initiate ESA Section 7 Consultation with the USFWS during the final design phase to support permitting and to address potential impacts to listed species.
2. The FDOT will conduct design-phase coverboard surveys in accordance with the most recent USFWS guidelines to verify activity and occupancy status of the blue-tailed mole skink and sand skink. Mitigation for impacts to occupied sand skink habitat will be provided as needed. Once the survey is completed, FDOT will then reinitiate formal consultation for the sand skink.
3. During the design and permitting phases of this project, the FDOT will coordinate with USFWS to determine if any additional Florida scrub-jay surveys are needed. Mitigation for impacts to occupied Florida scrub-jay habitat will be provided as needed.
4. The most recent version of the USFWS' Standard Protection Measures for the Eastern Indigo Snake will be adhered to during construction of the proposed project.
5. FDOT commits to continuing the Section 106 process by conducting the level of cultural resource survey or documentation appropriate for the proposed pond sites during the final design phase. Consultation with the SHPO, and appropriate parties as needed, regarding both this additional cultural resource effort and the official project effects finding will be completed thereafter to conclude the Section 106 process.

6. FDOT is committed to the construction of feasible and reasonable noise abatement measures at the noise impacted locations described above, contingent upon the following conditions:
  - a. Final recommendations on the construction of abatement measures is determined during the project's final design and through the public involvement process;
  - b. Detailed noise analyses during the final design process support the need, feasibility, and reasonableness of providing abatement;
  - c. Cost analysis indicates that the cost of the noise barrier(s) will not exceed the cost-reasonable criterion;
  - d. Community input supporting types, heights, and locations of the noise barrier(s) is provided to the District Office; and
  - e. Safety and engineering aspects as related to the roadway user and the adjacent property owner have been reviewed, and any conflicts or issues resolved.
7. FDOT commits to continued coordination with Osceola County regarding whether PPEC crosses over the proposed Celebration Boulevard Extension or proposed Celebration Boulevard Extension crosses over the PPEC.

#### 1.4 Alternatives Analysis Summary

Two Build Alternatives were evaluated in addition to the No-Build Alternative. Both Build Alternatives are identical except for differences at the Poinciana Parkway (SR 538)/I-4/SR 429 interchange. Below is a summary of the alternatives considered by segment and interchange:

- Poinciana Parkway (SR 538) Typical Section
  - Six lane typical section consisting of three travel lanes in each direction.
- SR 429 Typical Section
  - Twelve lane typical section consisting of four collector-distributor (C-D) lanes in each direction and two travel lanes in each direction.
- I-4 Typical Section
  - Twelve lane typical section consisting of four general use lanes in each direction and two managed lanes in each direction. This typical section is consistent with proposed improvements identified by the I-4 Beyond the Ultimate (BtU) project.
- Poinciana Parkway (SR 538) at CR 532 Interchange
  - Partial diamond interchange providing access to/from the north.



- Poinciana Parkway (SR 538)/I-4/SR 429 Interchange
  - Alternative 1: Provides system-to-system connections with the Poinciana Parkway (SR 538) southbound lanes located south of the Florida Gas Transmission (FGT) and Gulfstream facilities and the northbound lanes located north of the FGT and Gulfstream facilities.
  - Alternative 2: Similar to Alternative 1 except both directions of the Poinciana Parkway (SR 538) mainline are located south of the FGT and Gulfstream facilities.
- SR 429 at Sinclair Road Interchange
  - Modifications to existing diamond interchange.

The No-Build Alternative assumes no improvements to the roadway network except for routine maintenance. The No-Build remains a viable alternative throughout the PD&E Study.

### 1.5 Description of Preferred Alternative

The Preferred Alternative (Alternative 2) proposes the following elements:

- Extension of Poinciana Parkway (SR 538) from CR 532 to I-4 with a six lane typical section (three lanes in each direction).
- Construction of a partial diamond interchange along Poinciana Parkway (SR 538) at CR 532 providing access to/from the north.
- Expansion of the I-4/SR 429 interchange to include system to system connections with Poinciana Parkway (SR 538). The northbound and southbound lanes of Poinciana Parkway (SR 538) would be located south the FGT and Gulfstream facilities.
- Widening of SR 429 from I-4 to Sinclair Road to include twelve lanes (four C-D lanes in each direction and two travel lanes in each direction).
- Modification to the existing interchange at SR 429 and Sinclair Road to include additional turn lanes and signalization.
- Widening of I-4 in the vicinity of the Poinciana Parkway (SR 538)/I-4/SR 429 interchange to include 12 lanes with four general use lanes in each direction and two managed lanes in each direction.

### 1.6 List of Technical Documents

Below is a list of all technical documents that were prepared as part of this PD&E Study.

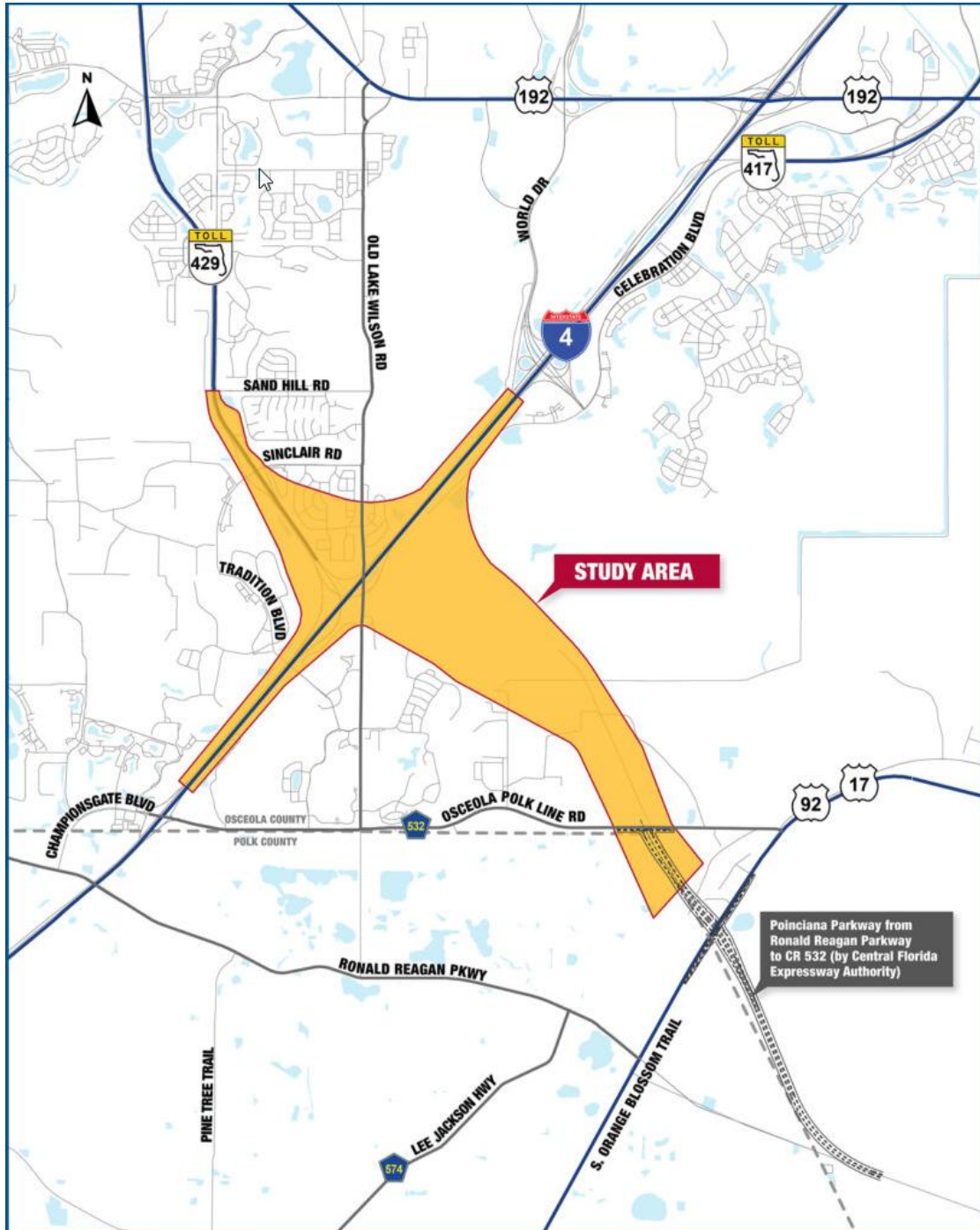
- Location Hydraulics Report
- Pond Siting Report
- Utilities Assessment Report

- Sociocultural Effects Evaluation
- Cultural Resource Assessment Survey
- Natural Resource Evaluation
- Air Quality Technical Memorandum
- Noise Study Report
- Contamination Screening Evaluation Report
- Section 4(f) Memo
- Conceptual Stage Relocation Plan
- Environmental Assessment

## 2.0 EXISTING CONDITIONS

The study area for the PPEC PD&E study is illustrated in Figure 2-1. The study area extends from south of CR 532 to Sand Hill Road and along I-4, from east of CR 532 to west of World Drive.

Figure 2-1: Study Area



## 2.1 Roadway

PPEC is a proposed new expressway which would extend from the portion of Poinciana Parkway (SR 538) currently under design by CFX. The extension of the mainline would start south of CR 532 and travel north to SR 429 at I-4. Modifications to SR 429 are included from I-4 to the north of Sand Hill Road.

The existing typical section and planned number of lanes for roadways in the study area are identified in Table 2-1.

Table 2-1: Roadway Number of Lanes

Roadway	From	To	Number of Lanes	
			Existing	Planned
SR 429	I-4	Sand Hill Road	4	8
I-4	CR 532	World Drive	6	12
CR 532	S. Old Lake Wilson Road	US 17/92	2	4
Sinclair Road	West of SR 429	East of SR 429	4	4
Sand Hill Road	West of SR 429	S. Old Lake Wilson Road	2	2
S. Old Lake Wilson Road	CR 532	Sand Hill Road	2	4
Connector Road	Sinclair Road	Sand Hill Road	2	2
Poinciana Parkway (SR 538)	US 17/92	CR 532	0	6*

\*Expandable to eight lanes

More detailed information about key roadways affecting potential concepts is provided below.

### 2.1.1 SR 429

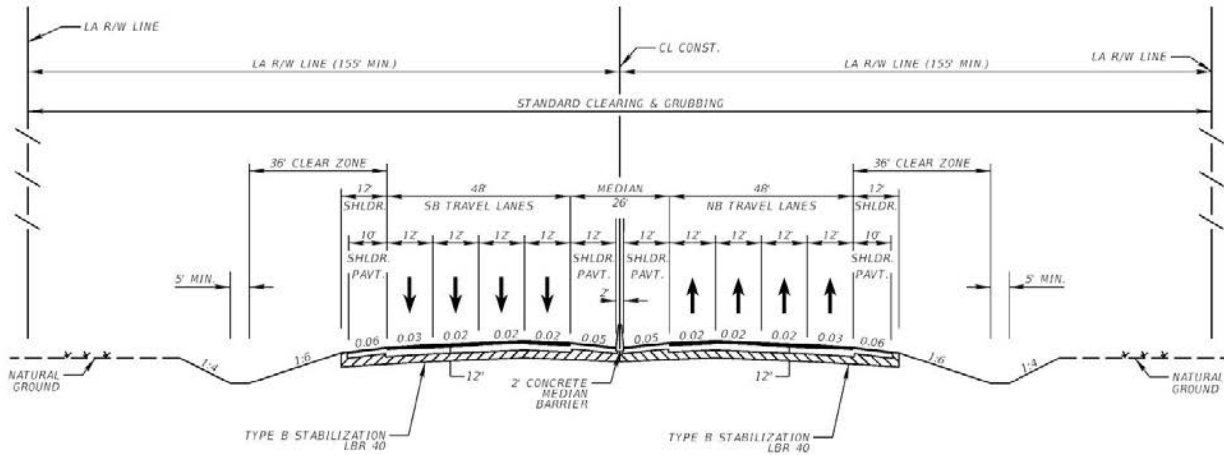
Within the study area, the SR 429 typical section includes four 12-foot lanes with a 64-foot median. ROW varies with a standard width of 300-feet. Interchanges are provided at I-4 and at Sinclair Road as described in Table 2-2.

Table 2-2: Existing Interchanges

Ramp Number/Name	Ramp Movement	Ramp Description
SR 429 at I-4		
Ramp A	Southbound SR 429 to Westbound I-4	One-lane system-to-system ramp. 15-foot lane with 8-foot outside shoulders (4 feet paved) and 6-foot inside shoulders (2 feet paved).
Ramp B	Eastbound I-4 to Northbound SR 429	One-lane system-to-system ramp with bridge on third level. 15-foot lane with 10-foot outside shoulders and 18-foot inside shoulders.
Ramp C	Southbound SR 429 to Eastbound I-4	One-lane system-to-system ramp with bridge on second level. 15-foot lane with 8-foot outside shoulders and 20-foot inside shoulders.
Ramp D	Westbound I-4 to Northbound SR 429	One-lane system-to-system ramp. 15-foot lane with 8-foot outside shoulders (4 feet paved) and 6-foot inside shoulders (2 feet paved).
SR 429 at Sinclair Road		
Ramp E	Sinclair Road to Southbound SR 429	One-lane ramp with toll plaza. 15-foot lane with 6-foot outside shoulders (2 feet paved) and 6-foot inside shoulders (4 feet paved).
Ramp F	Northbound SR 429 to Sinclair Road	One-lane ramp with toll plaza. 15-foot lane with 6-foot outside shoulders (2 feet paved) and 6-foot inside shoulders (4 feet paved).
Ramp G	Sinclair Road to Northbound SR 429	One-lane ramp. 15-foot lane with 6-foot outside shoulders (2 feet paved) and 6-foot inside shoulders (4 feet paved). Ramp connects to Connector Road between Sinclair Road and Sand Hill Road which is two lanes (12-foot lanes in each direction).
Ramp H	Southbound SR 429 to Sinclair Road	One-lane ramp. 15-foot lane with 6-foot outside shoulders (2 feet paved) and 6-foot inside shoulders (4 feet paved).

FTE is conducting a separate PD&E Study to widen Western Beltway (SR 429) from I-4 to Seidel Road (FPID: 446164-1-22-01). SR 429, from Sinclair Road to Seidel Road, currently has a four-lane divided typical section with a 56-foot median. The PD&E Study is evaluating improving this portion of SR 429 to an eight-lane expressway with a 26-foot median, as illustrated on Figure 2-2.

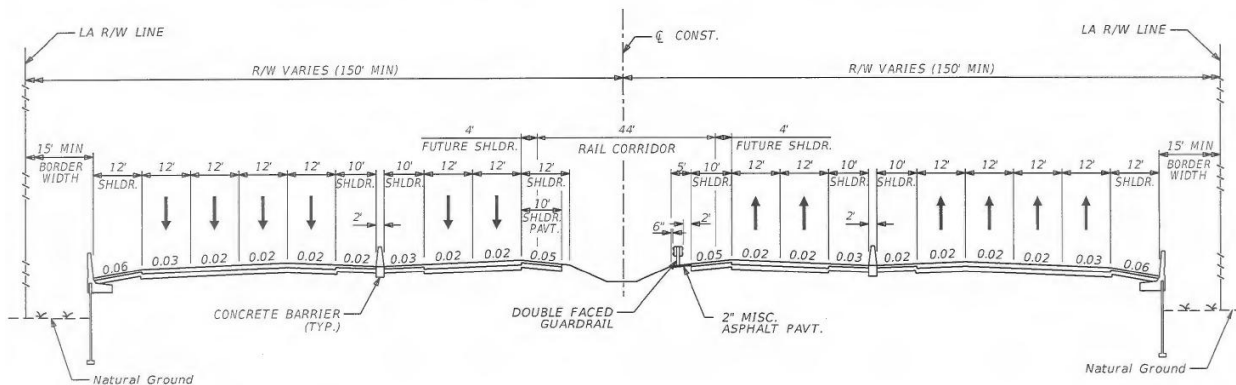
Figure 2-2: Typical Section – Planned SR 429



2.1.2 I-4

Within the study area, the I-4 typical section includes six 12-foot lanes with a 52-foot median. The extension of Poinciana Parkway (SR 538) to SR 429 at I-4 will need to be consistent with the I-4 BtU plans for I-4, which include reconstructing I-4 to accommodate managed lanes in each direction, as well as a rail envelope (Figure 2-3).

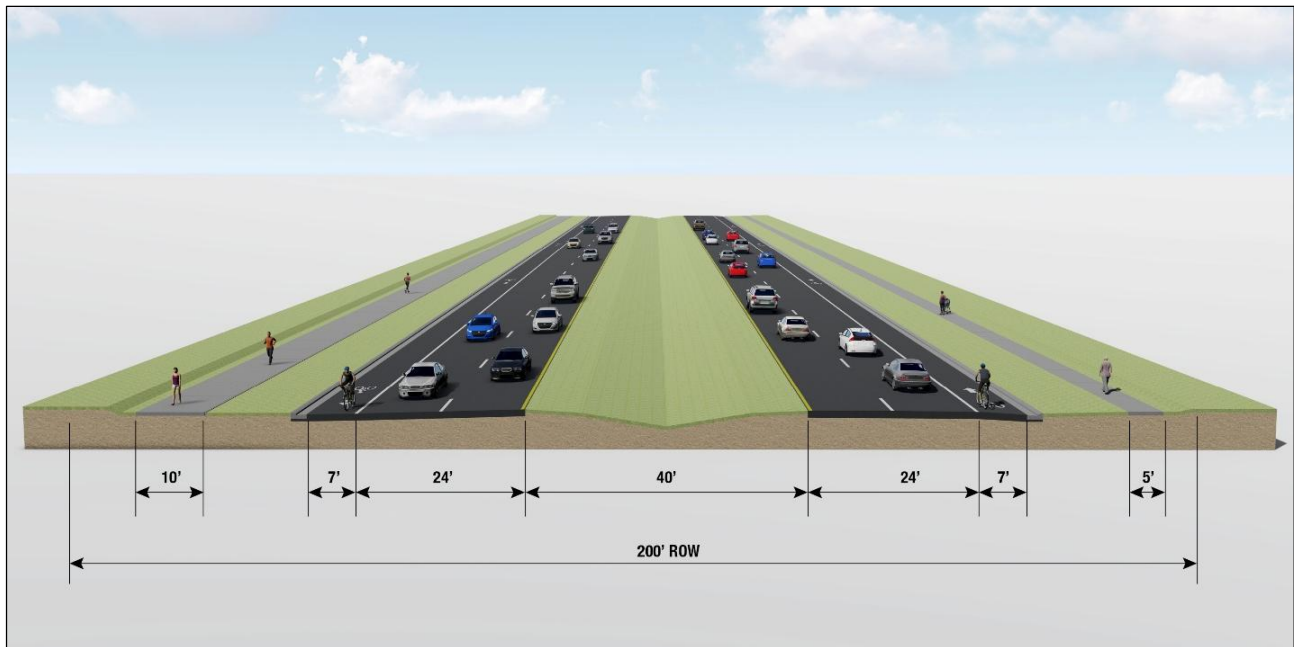
Figure 2-3: Typical Section – Planned I-4 BtU from CR 532 to SR 429



### 2.1.3 CR 532

Within the study area, the CR 532 typical section includes two 12-foot lanes. CFX and Osceola County are planning on widening CR 532 to a four-lane divided roadway with a 40-foot median, 7-foot bicycle lanes and pedestrian facilities, as illustrated on Figure 2-4. The construction of this improvement is programmed in 2023.

Figure 2-4: Typical Section – Planned CR 532



### 2.1.4 South Old Lake Wilson Road

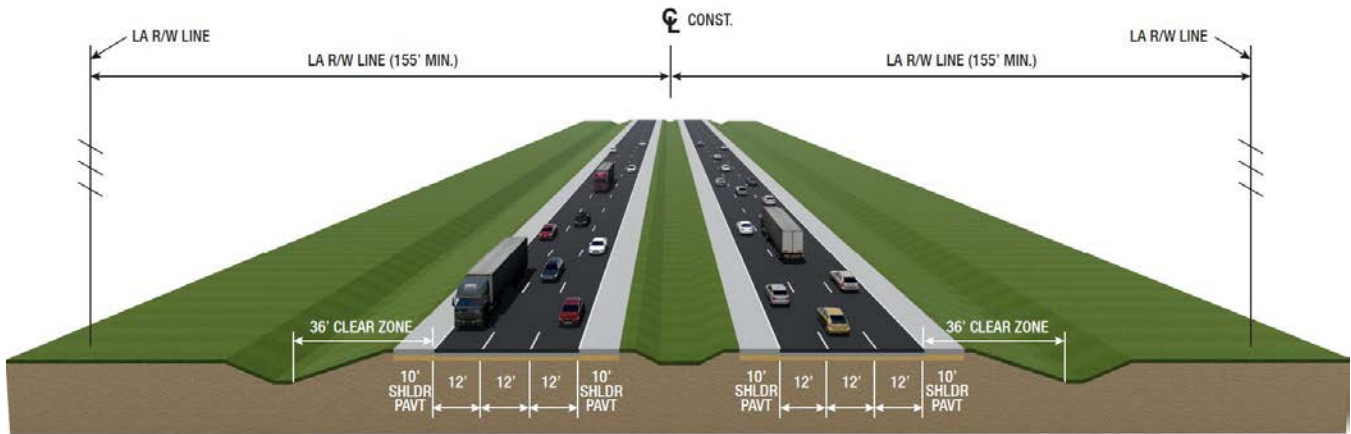
Within the study area, the S. Old Lake Wilson Road typical section includes two 12-foot lanes. Osceola County is currently conducting a PD&E study to improve this portion of S. Old Lake Wilson Road to a four-lane divided roadway. Osceola County anticipates construction to begin in 2025.

### 2.1.5 Poinciana Parkway (SR 538)

Poinciana Parkway (SR 538) from Ronald Reagan Boulevard to CR 532 is currently in design by CFX. The typical section for Poinciana Parkway (SR 538) includes six 12-foot lanes with a 74-foot median (see Figure 2-5). Poinciana Parkway (SR 538) will terminate at CR 532 and will be designed for the expressway to be extended north of CR 532. Construction is programmed by CFX in 2023.



Figure 2-5: Typical Section – Planned Poinciana Parkway (SR 538)



## 2.2 Right-of-Way

The existing ROW widths for the study area are summarized in Table 2-3.

Table 2-3: Existing Roadway Right-of-Way

Roadway	From	To	ROW Width
SR 429	I-4	Sand Hill Road	Varies (300 feet standard)
I-4	CR 532	World Drive	Varies (300 feet standard)
CR 532	S. Old Lake Wilson Road	US 17/92	200 feet
Sinclair Road	West of SR 429	East of SR 429	100 feet to 130 feet
Sand Hill Road	West of SR 429	S. Old Lake Wilson Road	85 feet
Connector Road	Sinclair Road	Sand Hill Road	Within SR 429 ROW
S. Old Lake Wilson Road	CR 532	Sand Hill Road	100 feet to 130 feet

## 2.3 Roadway Classification

The functional classification for key roadways within the study area are identified in Table 2-4.



Table 2-4: Roadway Functional Classification

Roadway	Functional Classification
SR 429	Urban Principal Arterial – Expressway
I-4	Urban Principal Arterial - Interstate
CR 532	Urban Minor Arterial
Sinclair Road	Urban Major Collector
Sand Hill Road	Urban Major Collector
Connector Road	Not Classified
S. Old Lake Wilson Road	Urban Minor Arterial

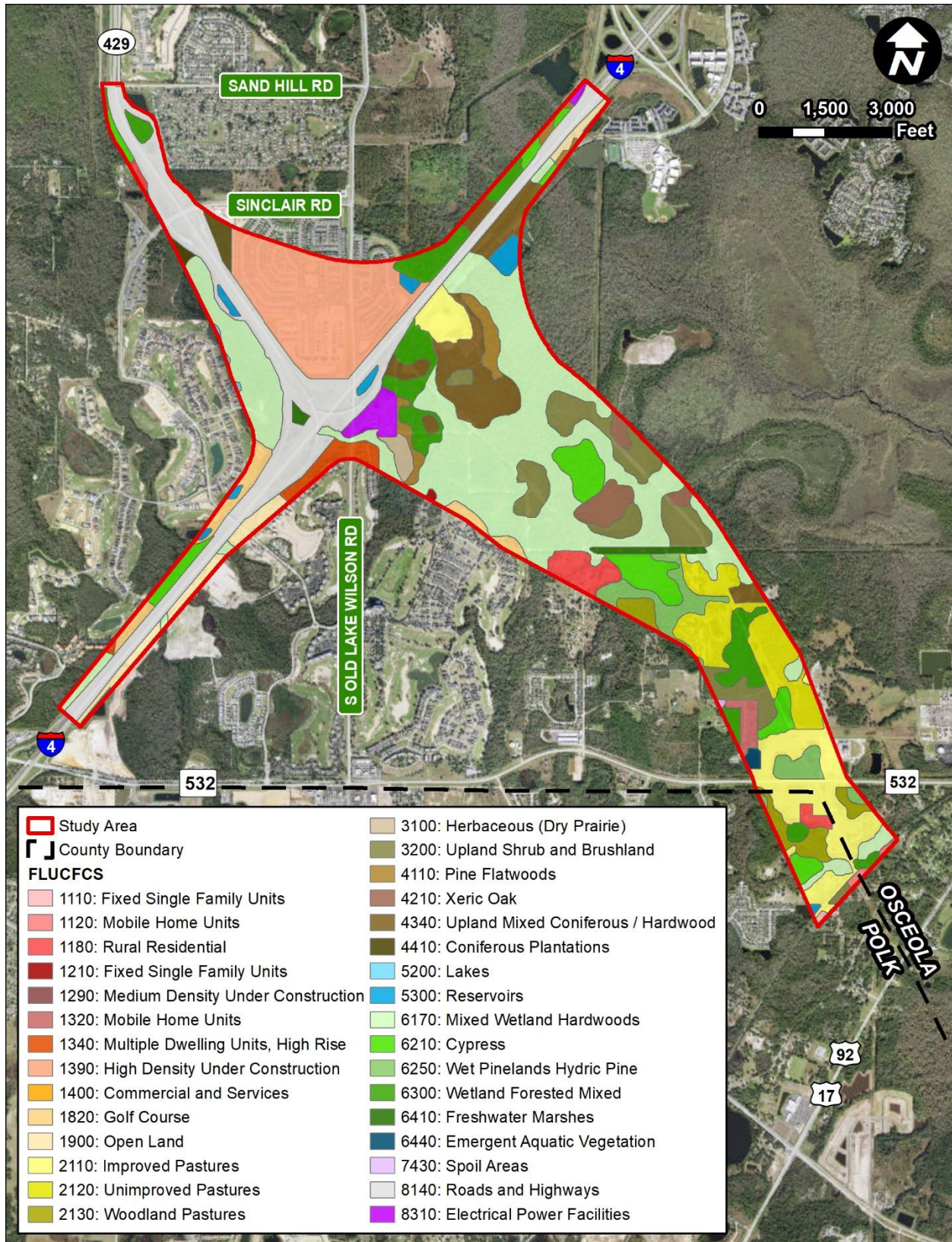
## 2.4 Adjacent Land Use

Property line data was obtained from the Osceola County Property Appraiser. Geographic Information System (GIS) data was obtained from the South Florida Water Management District (SFWMD) (2011) to assist in identifying land cover and natural communities. Land covers were classified according to the Florida Land Use, Cover, and Forms Classification System (FLUCFCS, FDOT, 1999). The general land cover within the study area consists of a mixture of developments (residential, commercial, community facilities), wetlands, agriculture (pastures, tree nurseries, citrus, etc.), and native uplands (pine flatwoods, xeric oak, live oak, and other hardwood forests). Table 2-5 provides the FLUCFCS data and acreage within the study area. The FLUCFCS data are indicated on Figure 2-6.

Table 2-5: Study Area FLUCFCS Summary and Acreage

FLUCFCS Code	FLUCFCS Type	Acres
1110	Fixed Single-Family Units	1.25
1120	Mobile Home Units	3.54
1180	Rural Residential	33.35
1210	Fixed Single-Family Units	1.23
1290	Medium Density Under Construction	0.06
1320	Mobile Home Units	12.02
1340	Multiple Dwelling Units, High Rise	22.29
1390	High Density Under Construction	196.09
1400	Commercial and Services	0.04
1820	Golf Course	34.49
1900	Open Land	38.81
2110	Improved Pastures	126.87
2120	Unimproved Pastures	99.29
2130	Woodland Pastures	32.99
3100	Herbaceous (Dry Prairie)	9.53
3200	Upland Shrub and Brushland	112.79
4110	Pine Flatwoods	27.59
4210	Xeric Oak	29.57
4340	Upland Mixed Coniferous/Hardwood	104.71
4410	Coniferous Plantations	13.14
5200	Lakes	2.05
5300	Reservoirs	23.46
6170	Mixed Wetland Hardwoods	479.25
6210	Cypress	91.40
6250	Wet Pinelands Hydric Pine	51.39
6300	Wetland Forested Mixed	109.25
6410	Freshwater Marshes	12.21
6440	Emergent Aquatic Vegetation	3.74
7430	Spoil Areas	0.67
8140	Roads and Highways	285.58
8310	Electrical Power Facilities	21.98
Grand Total		1980.66

Figure 2-6: Existing Land Use





Much of the study area has been developed or placed into conservation. Major developments include:

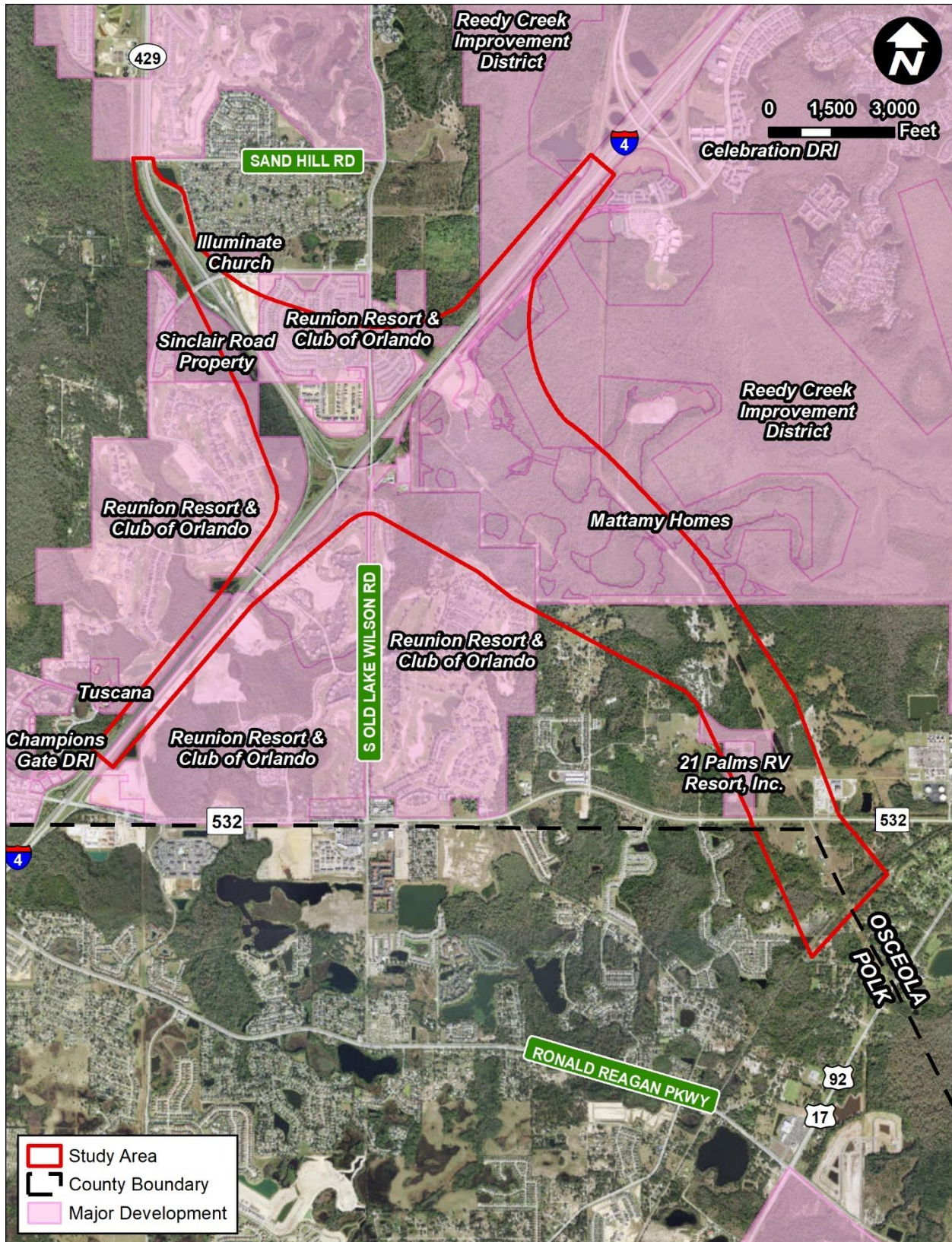
- Reunion Resort & Club of Orlando is a mixed-use development which is mostly complete with some undeveloped parcels scattered throughout the development, including along Watson Court, which is within the study area. Development is currently underway along the south side of I-4, between CR 532 and Tradition Boulevard, which is in the study area. The Reunion development includes conservation areas and golf courses within the study area.
- Celebration Island Village by Mattamy Homes is a residential development with the first phase of development currently underway. The development is located on the south side of I-4, west of World Drive, and east of Reunion Resort. These parcels were originally part of Celebration.
- Celebration is primarily located northeast of the study area; however, parcels along both sides of I-4 are within the study area. These parcels are easements for utilities, or are Celebration owned utilities. No additional development associated with Celebration is expected within the study area, except for a vacant commercial parcel located in the south quadrant of the I-4 interchange with World Drive. In addition, Celebration still owns some parcels within the Island Village – Celebration development.
- Tuscana is complete and a portion is within the study area.
- Champions Gate is outside of the study area.

Additional developments are proposed within or adjacent to the study area, including:

- Sinclair Road Property is a proposed development which includes 446 multi-family/townhomes, a convenience market with gas, and a fast-food restaurant. The Sinclair Road Property is located in the southwest quadrant of the Sinclair Road at SR 429 interchange.
- Illuminate Church is a proposed 42,000 square foot church proposed in the northeast quadrant of the Sinclair Road interchange at SR 429.

The major developments are displayed on Figure 2-7.

Figure 2-7: Major Developments





## 2.5 Access Management Classification

The access management classifications for study area roadways are identified in Table 2-6. The Florida Department of Transportation (FDOT) establishes the classification for I-4, SR 429, and Connector Road. Osceola County establishes the classification for the other roadways in the study area.

Table 2-6: Access Management Classification

Roadway	Access Management Classification
SR 429	1
I-4	1
CR 532	5 (when improved)
Sinclair Road	N/A
Sand Hill Road	N/A
Connector Road	1
S. Old Lake Wilson Road	N/A

Note: Access Class 1 = Limited access facilities, ingress and egress are only via interchanges; Access Class 5 = Restrictive control serving areas with existing moderate to extensive development

## 2.6 Design and Posted Speeds

The design speeds and posted speed limits for the major roadways in miles per hour (mph) are shown in Table 2-7.

Table 2-7: Design and Posted Speed Limits

Roadway	Design Speed (mph)	Posted Speed Limit (mph)
SR 429	70	70
I-4	70 <sup>1</sup>	65
CR 532	55-60 <sup>1</sup>	50-55
Sinclair Road	35	35
Sand Hill Road	45	45
Connector Road	35	35
S. Old Lake Wilson Road	50-60 <sup>1</sup>	45-55

Note: <sup>1</sup> – Design Speed estimated as five mph above posted speed

## 2.7 Vertical and Horizontal Alignment

Table 2-8 and Table 2-9 summarize the existing horizontal and existing vertical alignment of SR 429, respectively. This information was extracted from available as-built plans and existing survey.

Table 2-8: Existing Horizontal Alignment and Criteria

PI Station*	PC Station*	PT Station*	Design Speed (mph)	Existing Horizontal Curve		
				Radius (feet)	Length (feet)	SE
205+67.78	192+69.65	217+55.81	70	3,500.00	2,486.16	0.060
240+58.10	229+09.46	251+29.23	70	3,500.01	2,219.77	0.060
320+14.90	309+12.43	330+90.75	70	5,729.58	2,178.32	0.037
321+11.47	309+12.43	332+76.41	70	5,729.58	2,363.98	0.037
1362+39.34	1358+67.99	1366+10.62	70	22,918.31	742.63	NC
372+75.39	365+48.57	380+00.00	70	10,742.96	1,451.43	
434+70.84	400+00.00	467+14.23	70	10,742.96	6,714.23	
1376+90.46	1373+86.33	1379+94.22	70	7,161.97	607.89	0.037
135+87.13	126+85.39	144+32.62	70	2,865.00	1,747.23	0.070
938+02.08	934+81.26	940+66.18	70	573.00	584.93	0.081

\*Stations are taken from as-builts and may differ from those shown in the Conceptual Design plan sheets

Table 2-9: Existing Vertical Alignment and Criteria

PVI* Station	Design Speed (mph)	Existing Vertical Curve						Curve Length Min. (ft.)	K-Value Criteria	
		Type	G1 %	G2 %	A %	Length (feet)	K-Value		FDM	AASHTO
67+50	70	Sag	-5	0.470	5.47	1,100	201	400	206	181
98+00	70	Sag	-0.791	0.401	1.192	600	503	400	206	181
105+00	70	Crest	0.401	-0.582	0.983	500	509	500	506	247
141+00	70	Crest	2.273	-2.103	4.376	2190	500	500	506	247
156+00	70	Sag	-2.103	1.388	3.491	700	201	400	206	181
167+00	70	Crest	1.386	-1.386	2.772	1,400	505	500	506	247
194+00.00	70	Sag	-1.386	0.227	1.613	800	496	400	206	181
210+50	70	Crest	0.227	-0.779	1.006	1,300	1,291	500	506	247
221+10.00	70	Sag	-0.779	0.501	1.28	800	625	400	206	181



SECTION 2 – EXISTING CONDITIONS

PVI* Station	Design Speed (mph)	Existing Vertical Curve						Curve Length Min. (ft.)	K-Value Criteria	
		Type	G1 %	G2 %	A %	Length (feet)	K-Value		FDM	AASHTO
240+00.00	70	Crest	0.336	-0.305	0.641	1,000	1,559	500	506	247
249+50.00	70	Sag	-0.305	2.786	3.091	800	259	400	206	181
267+18.69	70	Crest	2.786	-2.687	5.473	2,737.38	500	500	506	247
285+76.00	70	Sag	-2.687	-0.300	2.387	800	335	400	206	181
293+75.00	70	Sag	-0.300	0.300	0.6	800	1,333	400	206	181
302+00.00	70	Sag	0.300	2.352	2.052	800	390	400	206	181
320+50.00	70	Crest	2.352	-2.530	4.882	2,500	512	500	506	247
1339+00.00	70	Sag	-2.530	-0.034	2.496	800	321	400	206	181
1360+00.00	70	Sag	-0.034	0.240	0.274	800	2,915	400	206	181
1379+49.46	70	Sag	0.240	1.452	1.212	800	660	400	206	181
419+00.00	70	Crest	1.452	-1.600	3.052	1,500	524	500	506	247
432+00.00	70	Sag	-1.600	0.680	2.28	800	351	400	206	181
458+00.00	70	Crest	0.680	-1.120	1.8	1,800	1,000	500	506	247
492+00.00	70	Sag	-1.120	-0.360	0.76	1,000	1,316	400	206	181
490+00.00	70	Sag	0.360	0.200	0.56	800	1,429	400	206	181
517+00.00	70	Sag	0.200	0.662	0.462	800	500	400	206	181
542+00.00	70	Crest	0.782	0.200	0.582	1,000		500	506	247
542+00.00	70	Crest	0.662	0.200	0.462	1,000		500	506	247
577+00.00	70	Crest	0.200	-0.960	1.16	1,000		500	506	247
577+00	70	Crest	0.200	-0.746	0.946	1,000		500	506	247
591+00.00	70	Sag	-0.960	0.380	1.34	800		400	206	181
622+00.00	70	Crest	0.380	-1.233	1.613	1,800		500	506	247
592+00.00	70	Sag	-1.233	0.906	2.139	800		400	206	181

\*Stations are taken from as-built plans and may differ from those shown in the Conceptual Design plan sheets.

## 2.8 Pedestrian Accommodations

The existing pedestrian facilities within the study area are summarized in Table 2-10.

Table 2-10: Pedestrian Facilities

Roadway	Existing Pedestrian Facilities	Comment
SR 429	None	Prohibited within Limited Access
I-4	None	Prohibited within Limited Access
CR 532	None	Programmed for sidewalk or multiuse path on both sides
Sinclair Road	Yes	Sidewalks on both sides
Sand Hill Road	None	
Connector Road	None	Prohibited within Limited Access
S. Old Lake Wilson Road	Partial	Sidewalks on both sides north of I-4

## 2.9 Bicycle Facilities

The existing bicycle facilities within the study area are summarized in Table 2-11.

Table 2-11: Bicycle Facilities

Roadway	Existing Bicycle Facilities	Comment
SR 429	None	Prohibited within Limited Access
I-4	None	Prohibited within Limited Access
CR 532	None	Programmed for bicycle lanes on both sides
Sinclair Road	None	
Sand Hill Road	None	
Connector Road	None	Prohibited within Limited Access
S. Old Lake Wilson Road	None	Osceola County PD&E Study evaluating five-foot bike lanes

## 2.10 Transit Facilities

There are no transit stops (or routes) in the study area. Based on the latest Osceola County Comprehensive Plan - 2040 Transit System plans, transit-related improvements are not planned within the study area.

## 2.11 Pavement Condition

Pavement condition surveys for 2021 for SR 429 were reviewed to assess the condition of this facility. A scale of one to ten is used to rate the pavement conditions for cracking and ride, where “one” is the worst condition and “ten” is the best, and any rating less than six is considered

deficient. When evaluated in 2021, the SR 429 pavement condition survey within Osceola County indicated a range from 6.5 to 7.5 for cracking and 7.7 for ride. Milling and resurfacing is currently under construction and will improve pavement conditions along SR 429, from MP 1 to MP 5.5 in Osceola County (FPID 440289-1) and from MP 5.5 to MP 11 in Orange County (FPID 440290-1). Construction is anticipated to be completed by the end of 2022.

### 2.12 Traffic Volumes and Operational Conditions

Existing Annual Average Daily Traffic (AADT) volumes for I-4 and SR 429 are provided in Table 2-12 and existing peak hour volumes are provided in Figure 2-8. A summary of existing operational conditions is provided in Table 2-13. Each of the intersections currently operates at a LOS E or F in the AM conditions, except for the SR 429 ramp terminal intersections at Sinclair Road which operates at LOS C or better. In the PM conditions, most of the intersections operate unacceptably at LOS E or F, except for the Sinclair Road and SR 429 northbound ramps terminal intersection. Several movements are reported with an unacceptable LOS F at each of the intersections along CR 532 and US 17/92.

Table 2-12: 2020 (Existing) Annual Average Daily Traffic

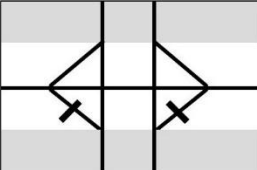
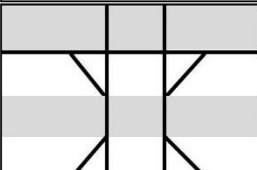
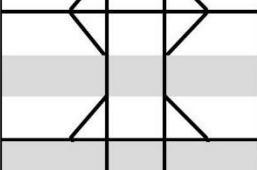
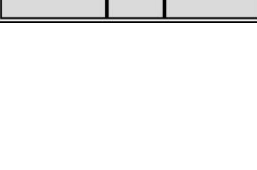
Location	SR 429	Southbound	Northbound	Total
<b>1-Sinclair Road</b>		<b>19,100</b>	<b>14,200</b>	<b>33,300</b>
		3,700	3,100	6,800
		3,000	2,300	5,300
<b>0 - I-4</b>	To/From I-4 West	<b>18,400</b>	<b>13,400</b>	<b>31,800</b>
	To/From I-4 East	14,600	11,200	25,800
		3,800	2,200	6,000
Location	I-4	Eastbound	Westbound	Total
<b>World Drive</b>		<b>43,200</b>	<b>45,300</b>	<b>88,500</b>
		21,500	18,300	39,800
<b>SR 429</b>		<b>64,700</b>	<b>63,600</b>	<b>128,300</b>
		14,600	2,200	16,800
<b>CR 532</b>		<b>72,100</b>	<b>76,000</b>	<b>148,100</b>
		3,800	11,200	15,000
		<b>16,100</b>	<b>19,700</b>	<b>35,800</b>
		<b>56,000</b>	<b>56,300</b>	<b>112,300</b>

Figure 2-8: 2020 (Existing) Peak Hour Volumes



Table 2-13: 2020 (Existing) AM/PM Peak Hour Intersection Level of Service/Delay (s/veh)

Intersection	Eastbound			Westbound			Northbound			Southbound			Overall
	Left	Thru	Right	Left	Thru	Right	Left	Thru	Right	Left	Thru	Right	
<b>AM</b>													
Sinclair Road and SR 429 SB Ramps*	-	A/0	A/0.2	A/8.5	A/0	-	-	-	-	C/19.2	A/8.8	A/8.8	C/19.2
Sinclair Road and SR 429 NB Ramps	B/12.1	A/9.5	-	-	A/4.9	A/4.9	A/9.5	A/9.3	A/3.7	B/10.5	B/10.5	B/10.5	A/7.5
CR 532 and Lake Wilson Road	<b>F/150.9</b>	E/63.9	B/16.4	<b>F/147.6</b>	<b>F/81.8</b>	E/66.1	E/55.7	<b>F/85.2</b>	<b>F/85.2</b>	D/49.1	E/65.2	E/65.2	<b>E/76.6</b>
CR 532 and US 17/92	D/46.6	-	A/7.2	-	-	-	<b>F/287.0</b>	E/61.0	-	-	C/23.5	A/7.7	<b>E/58.3</b>
US 17/92 and Ronald Regan Parkway	<b>F/548.1</b>	B/18.2	B/18.2	D/46.4	<b>F/100.2</b>	B/14.8	<b>F/654.5</b>	C/34.0	A/0.2	D/46.0	C/27.1	B/16.8	<b>F/161.0</b>
<b>PM</b>													
Sinclair Road and SR 429 SB Ramps*	-	A/0	A/0.1	A/7.9	A/0	-	-	-	-	E/38.5	-	A/9.6	<b>E/38.5</b>
Sinclair Road and SR 429 NB Ramps	B/17.8	B/15.4	-	-	A/7.2	A/7.2	A/8.4	A/7.5	A/2.6	C/22	C/22	C/22	B/12.8
CR 532 and Lake Wilson Road	<b>F/307.1</b>	<b>F/89.6</b>	D/38.8	<b>F/138.7</b>	<b>F/85.7</b>	A/8.8	<b>F/459.3</b>	<b>F/86</b>	<b>F/86</b>	<b>F/294.7</b>	<b>F/114.8</b>	<b>F/114.8</b>	<b>F/171.7</b>
CR 532 and US 17/92	<b>F/328.0</b>	-	C/20.0	-	-	-	<b>F/92.3</b>	C/21.1	-	-	<b>F/276.7</b>	A/4.6	<b>F/185.3</b>
US 17/92 and Ronald Regan Parkway	<b>F/231.2</b>	<b>F/136.0</b>	<b>F/136.0</b>	D/49.7	D/40.6	A/0.4	<b>F/201.5</b>	C/24.7	A/0.2	<b>F/98.5</b>	D/35.3	A/4.4	<b>F/84.5</b>

## 2.13 Intersection Layout and Traffic Control

Existing intersection layout and traffic control information is summarized in Figure 2-9.

Figure 2-9: Existing Intersection Layout and Control



## 2.14 Railroad Crossings

The CSX Railroad (single track) travels through the southern portion of the study area and the planned PPEC will tie into the portion of Poinciana Parkway (SR 538) currently under design by CFX approximately 1,200 feet north of the CSX Railroad. CSX has a 100-foot-wide ROW through this area.

Freight and Amtrak passenger trains utilize this line. SunRail passenger service from Orlando terminates approximately 4.6 miles east of the planned Poinciana Parkway (SR 538) crossing. Due to restrictions on freight traffic using the rail lines during SunRail operation, the train crossings at CR 532 occur during the period from approximately 10:00 PM until 6:00 AM during weekdays. CSX operates seven trains a day at this crossing with a maximum speed of 79 mph. Amtrak passenger train crossings occur based on scheduling and range from approximately 6:00 AM to 7:00 PM all week. Amtrak operates an average of four trains a day at this crossing with a typical speed range of 60-79 mph. There are currently no short or long-term improvements planned for the Amtrak train route that would affect the area. The potential restructuring of the Florida Amtrak system may impact the crossing in the future.

## 2.15 Crash Data and Safety Analysis

### 2.15.1 Crash Data Analysis

Crash data for state roads within the project area were processed using five-year data from the FDOT's Crash Analysis Reporting System (CARS), from 2014 through 2018. Crash data for non-state roads were obtained from the Signal Four Analytics tool, an FDOT-funded database developed in coordination with the state's CARS. Signal Four data were processed from 2014 through 2018, the same time period as the CARS data.

A total of 1,189 crashes were reported along I-4 and SR 429 during the five-year study period from 2014 through 2018, as presented in Table 2-14. The number of crashes in the study area increased each year. Most of the crashes resulted in injury and property damage only. Seven fatal crashes were reported during the five-year analysis period.

Table 2-14: I-4 and SR 429 Corridor Crashes and Severity by Year

Crash Severity	2014	2015	2016	2017	2018	Total	Proportion
Fatality	0	3	2	0	2	7	1%
Injury	52	74	97	116	145	484	41%
Property Damage Only	73	110	129	174	212	698	59%
Total	125	187	228	290	359	1189	100%

Table 2-15 summarizes the crashes based on location. 96% of the crashes occurred on the I-4 mainline and 4% along the SR 429.

Table 2-15: Number of Crashes by Location and Year

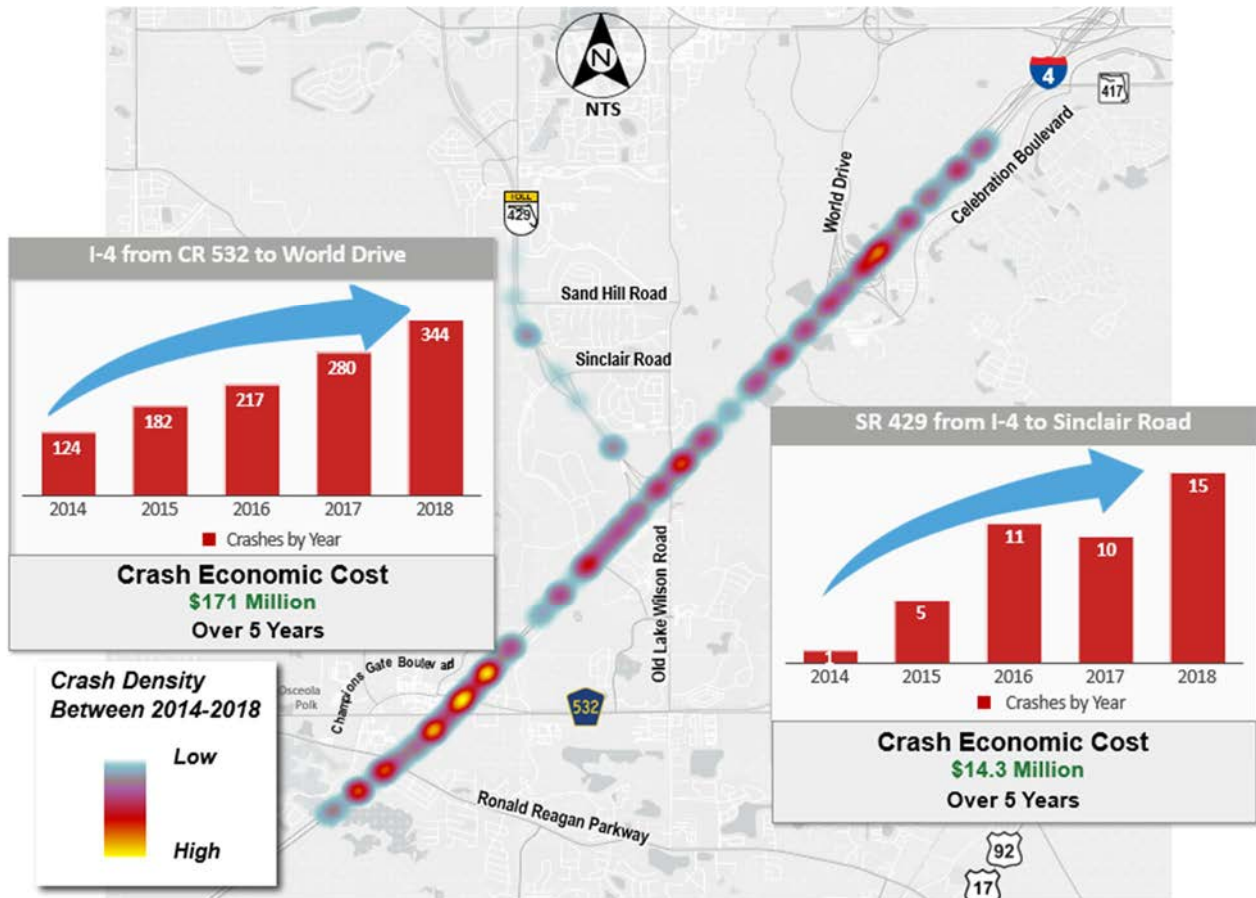
Roadway Segment	2014	2015	2016	2017	2018	Total	Proportion
I-4 Mainline	124	182	217	280	344	1147	96%
SR 429 Mainline	1	5	11	10	15	42	4%
Total	125	187	228	290	359	1189	100%

### *2.15.2 Mainline and Interchange Crashes*

Figure 2-10 shows crash locations along the SR 429 and I-4 mainline. Most of the crashes along the SR 429 mainline occurred at the merge/diverge areas of the interchanges. The crashes are higher especially at the I-4 and SR 429 interchange due to congestion on the roadway which results in traffic backing up on to the mainline.



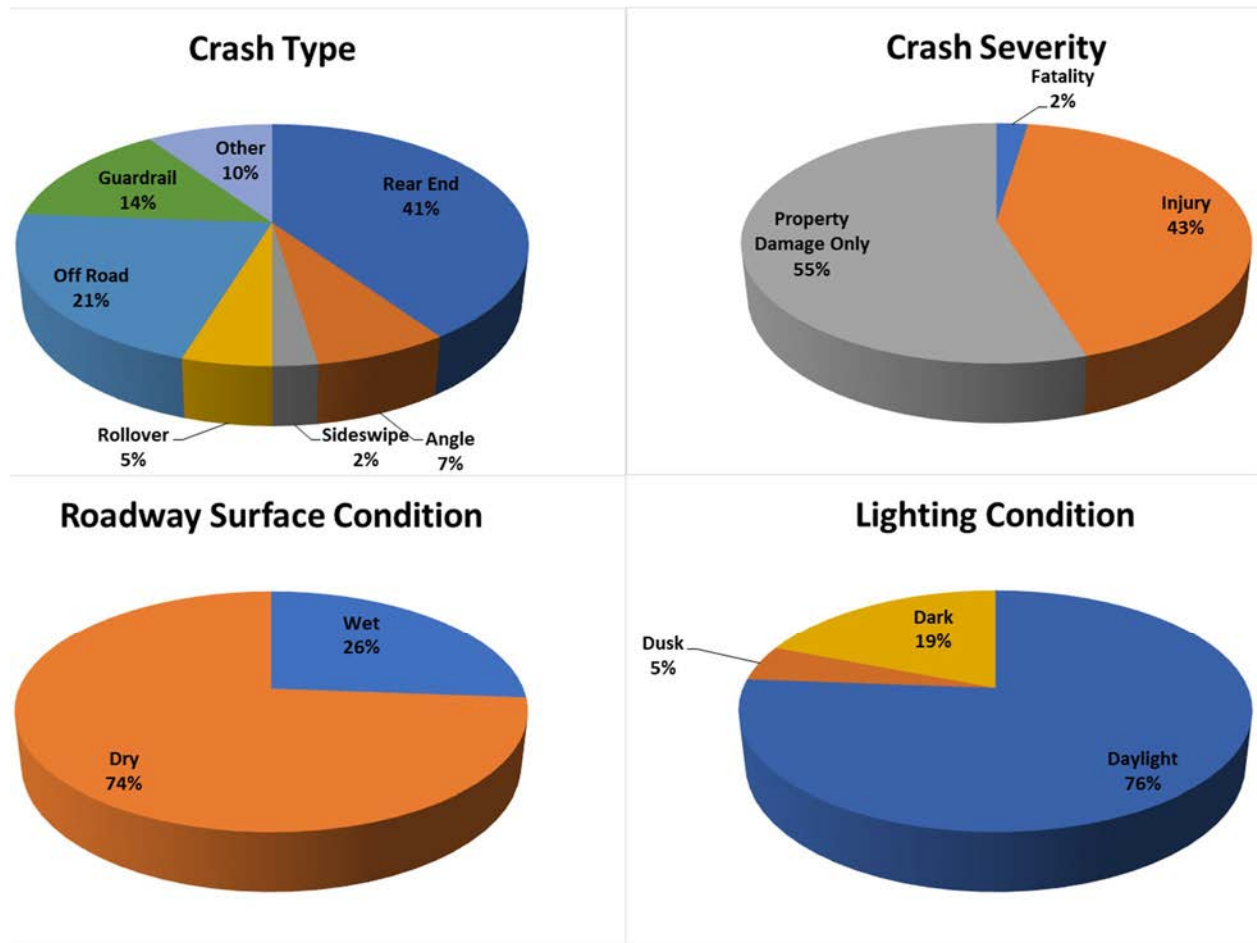
Figure 2-10: Crash Locations along the SR 429 and I-4 Mainline



### SR 429 Mainline from MP 0 to MP 2

A total of 42 crashes were reported along the SR 429 mainline between I-4 and the Sinclair Road interchange during the five-year analysis period from 2014 through 2018. The mainline crashes were mostly rear end (41%) and off-road (21%), as illustrated on Figure 2-11. A majority of the crashes resulted in property damage only (55%) and occurred on dry pavement conditions during the day. One fatal crash was reported within the five-year study period, which was caused by a rear-end crash during the day.

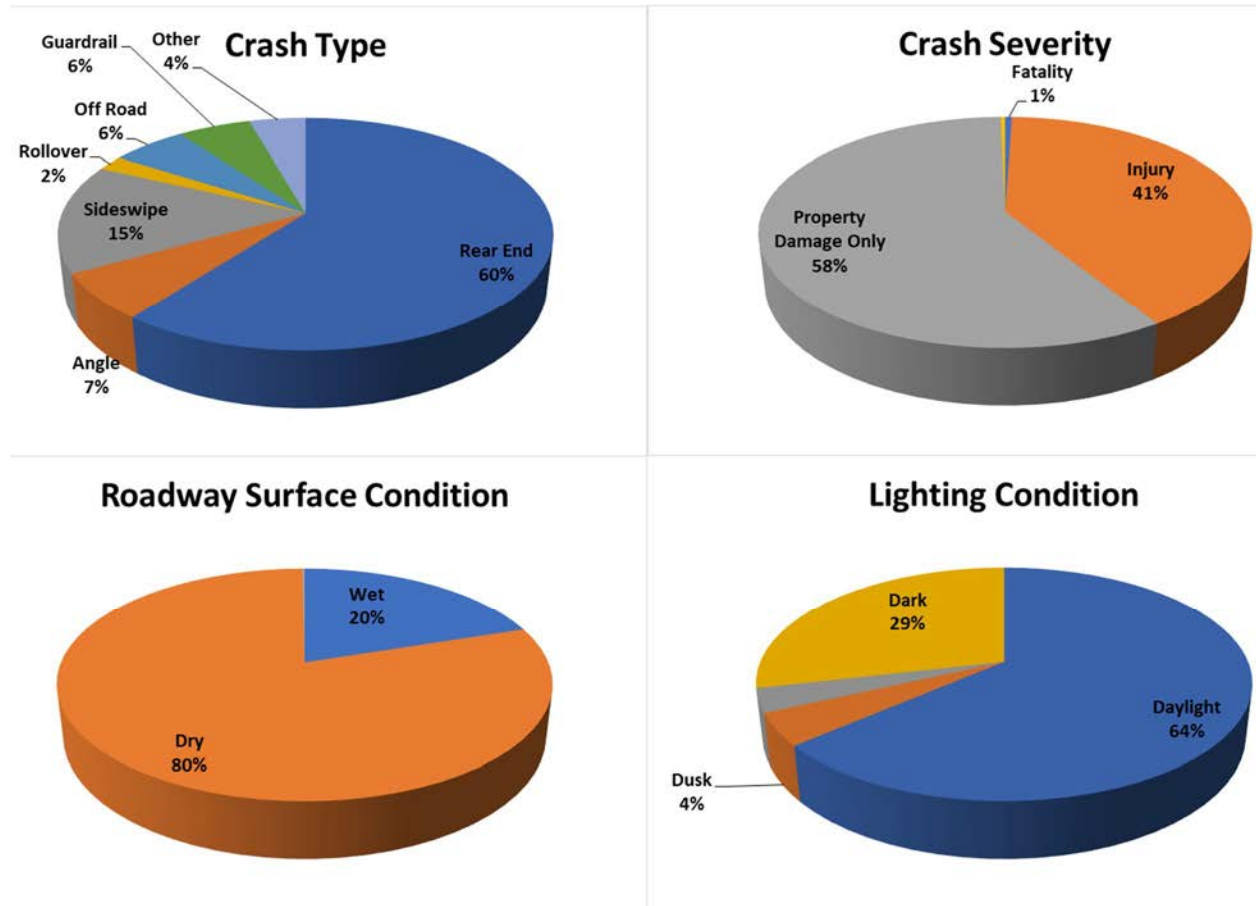
Figure 2-11: Crash Data Summary – SR 429 Mainline from MP 0 to MP 2



*I-4 Mainline between World Drive and CR 532 (MP 0 to MP 5.235 and MP 30.935 to MP 32.022)*

A total of 1,147 crashes were reported along the I-4 mainline from the CR 532 to World Drive interchanges during the five-year analysis period. Most of the crashes were rear-end type resulting in property damage only and occurred under dry road surface conditions during the day, as shown on Figure 2-12.

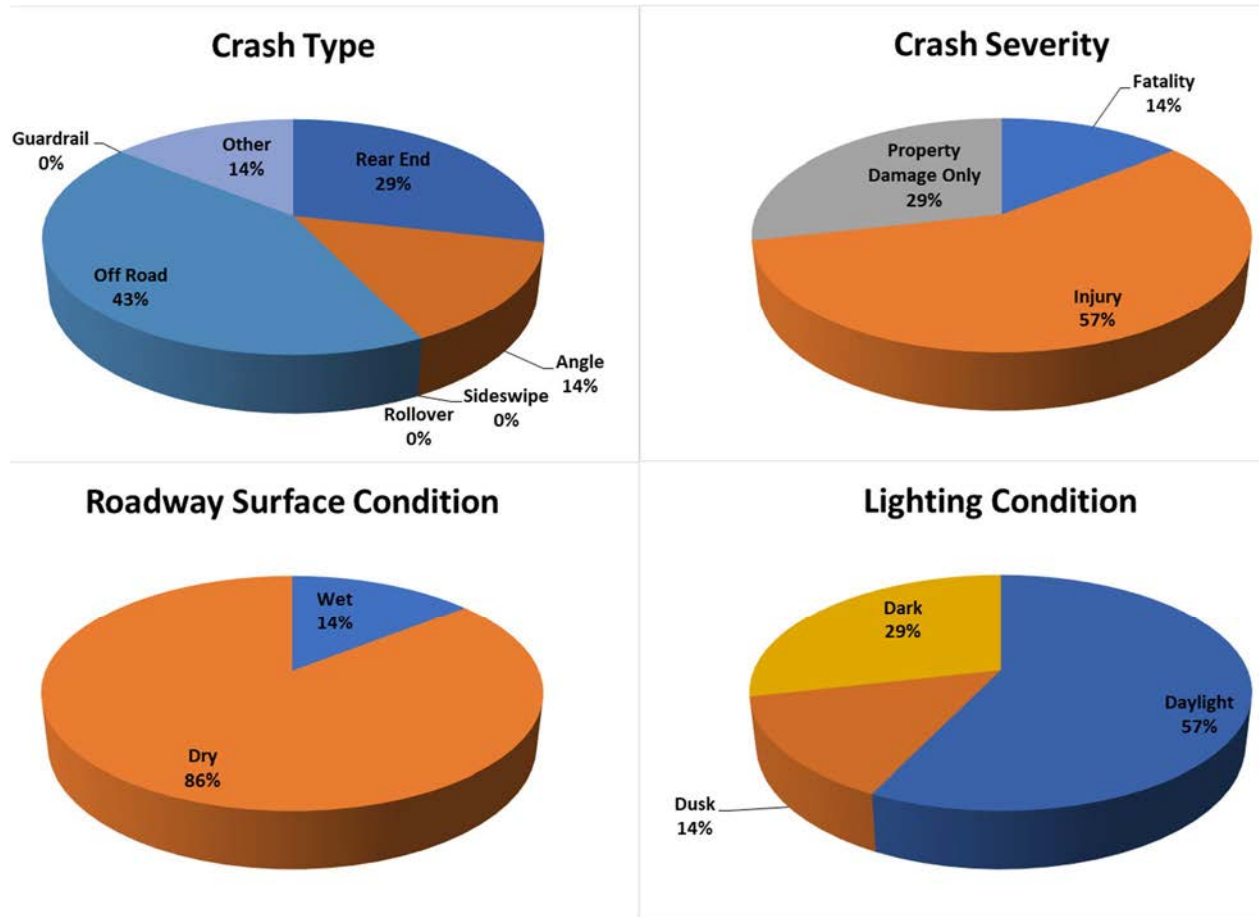
Figure 2-12: Crash Data Summary – I-4 Mainline



*SR 429 at Sinclair Road Interchange Ramps (MP 1)*

A total of seven crashes were reported along the Sinclair Road interchange ramps during the five-year analysis period. Three of the crashes were rear-end crashes and one was an angle crash. One fatality was reported, which was caused by an off-road motorcycle crash at 5:40 PM on a Saturday. The crash forms show that the motorcycle was traveling in the wrong direction on the northbound off-ramp. The crashes occurred under dry road surface conditions mostly during the day, as shown on Figure 2-13.

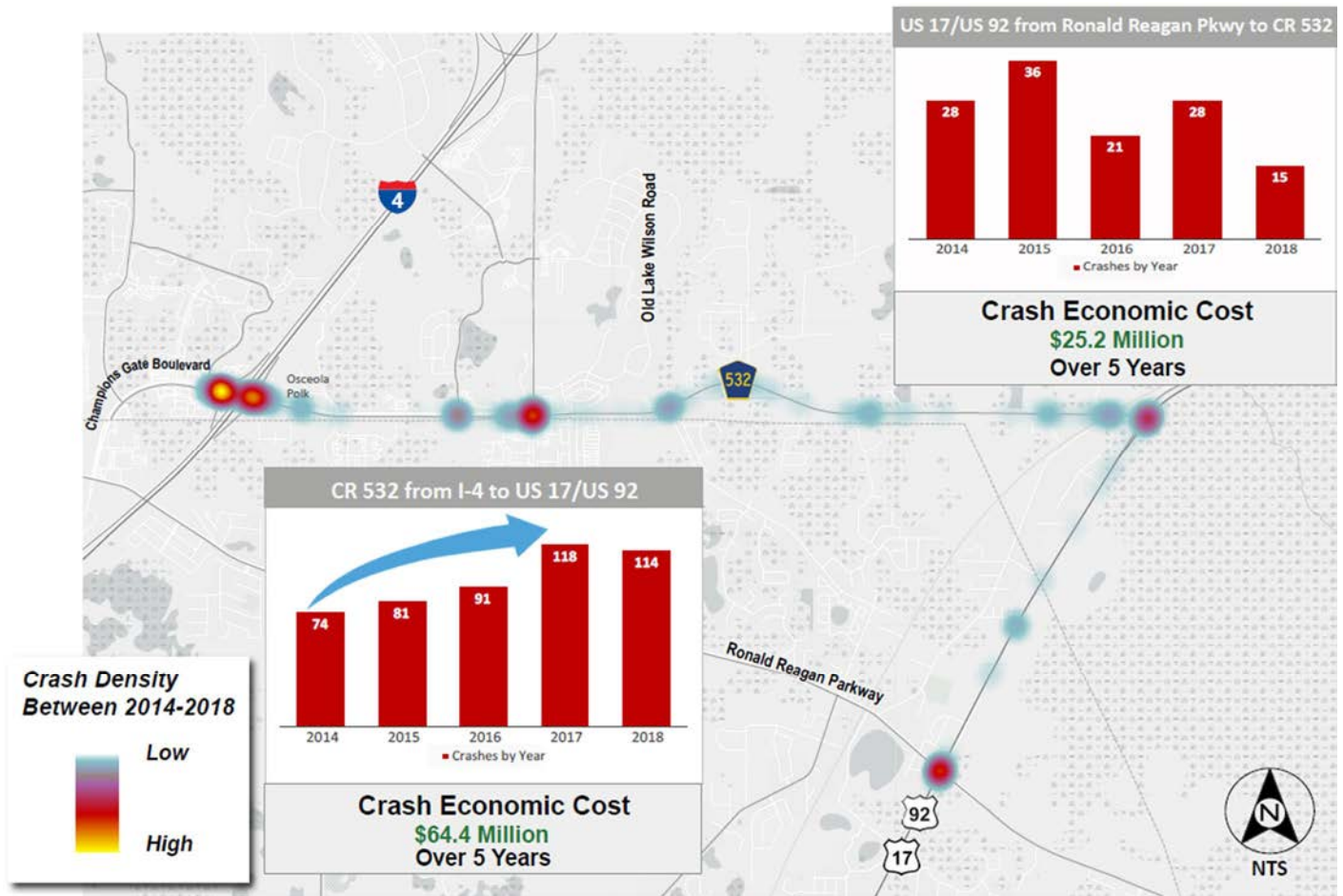
Figure 2-13: Crash Data Summary – SR 429 at Sinclair Road Ramps



### 2.15.3 Intersection Crashes

Figure 2-14 shows crash locations along CR 532 and US 17/US 92. Most of the crashes along CR 532 occurred at the merge/diverge areas of the interchange with I-4 and at the S. Old Lake Wilson Road intersection. The crashes are higher especially at the I-4 interchange due to congestion on the roadway.

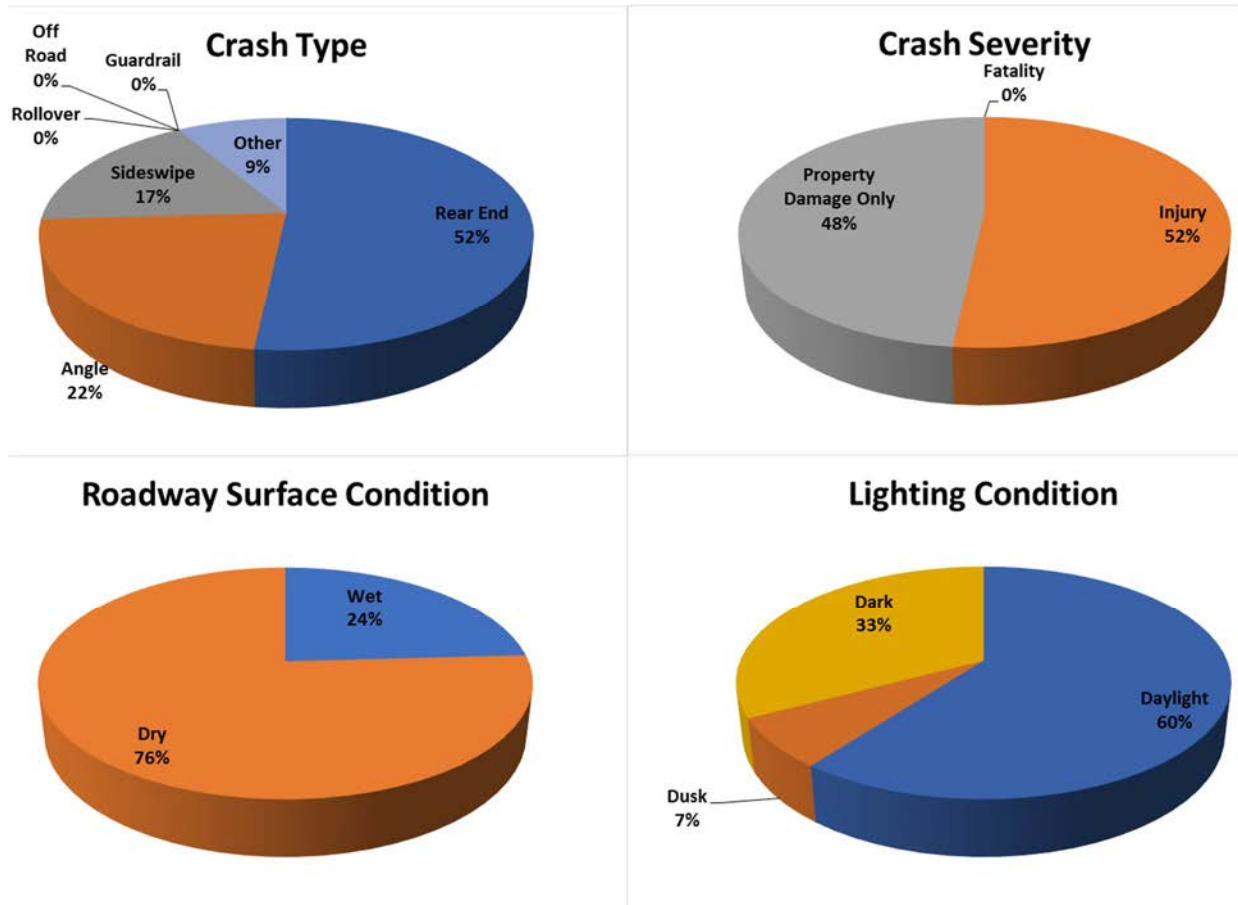
Figure 2-14: Crash Locations along CR 532 and US 17/US 92



A total of 58 crashes were reported at the CR 532 and Lake Wilson Road intersection during the five-year analysis period. Crash occurrence was more frequent during the weekdays compared to the weekends. As illustrated on Figure 2-15, most of the crashes were rear end collisions. 48% of the crashes resulted in property damage only. No fatal crashes were reported in the five-year period. Most of the crashes occurred under dry road surface conditions during the day.



Figure 2-15: Crash Data Summary – CR 532 & Lake Wilson Road Intersection



The reports showed that 27 crashes occurred at the CR 532 and US 17/92 intersection from 2014 through 2018. Crash occurrence was evenly distributed throughout the week. As depicted on Figure 2-16, the prominent crash types were rear end and angle crashes and occurred mostly under dry road surface conditions during the day. No fatal crashes were reported during the five-year analysis period.

Figure 2-16: Crash Data Summary – CR 532 & US 17/92 Intersection

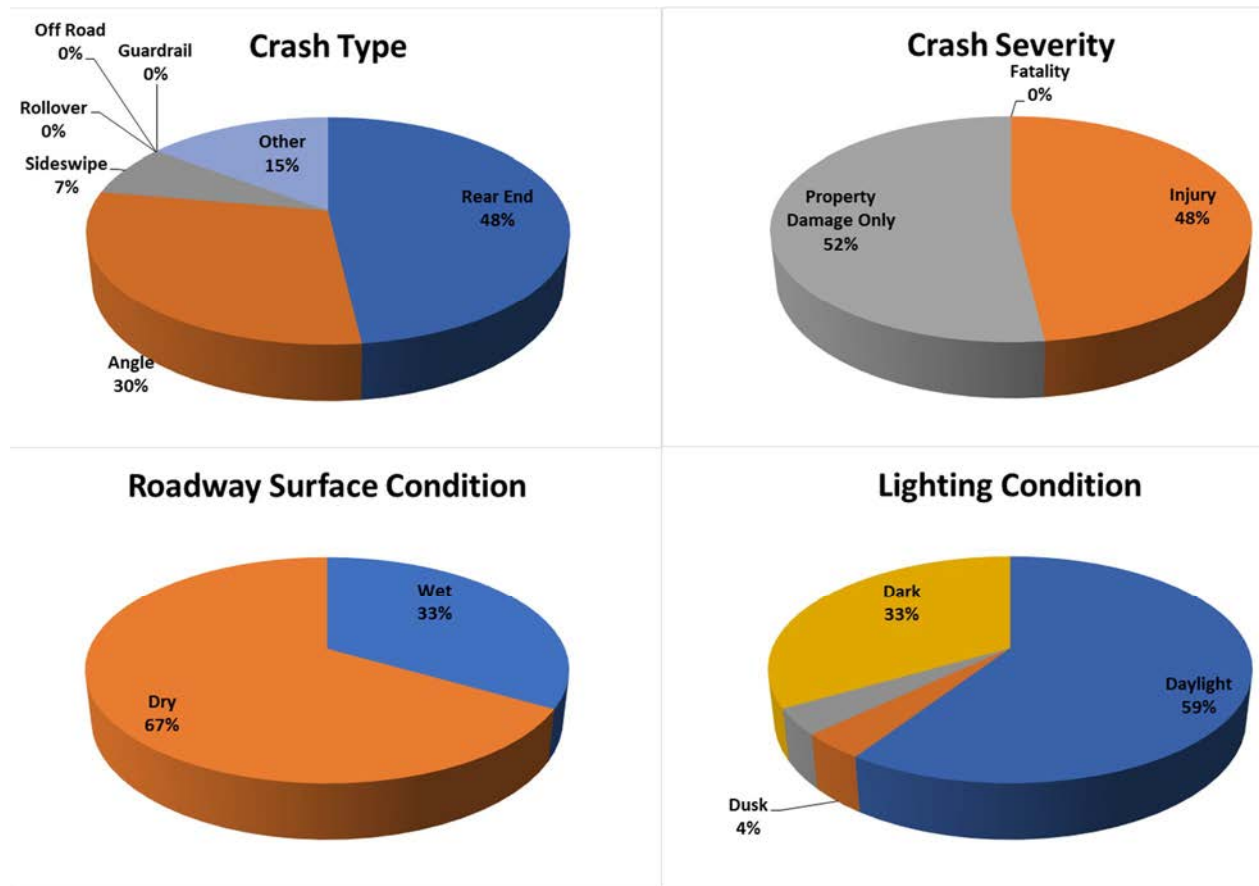
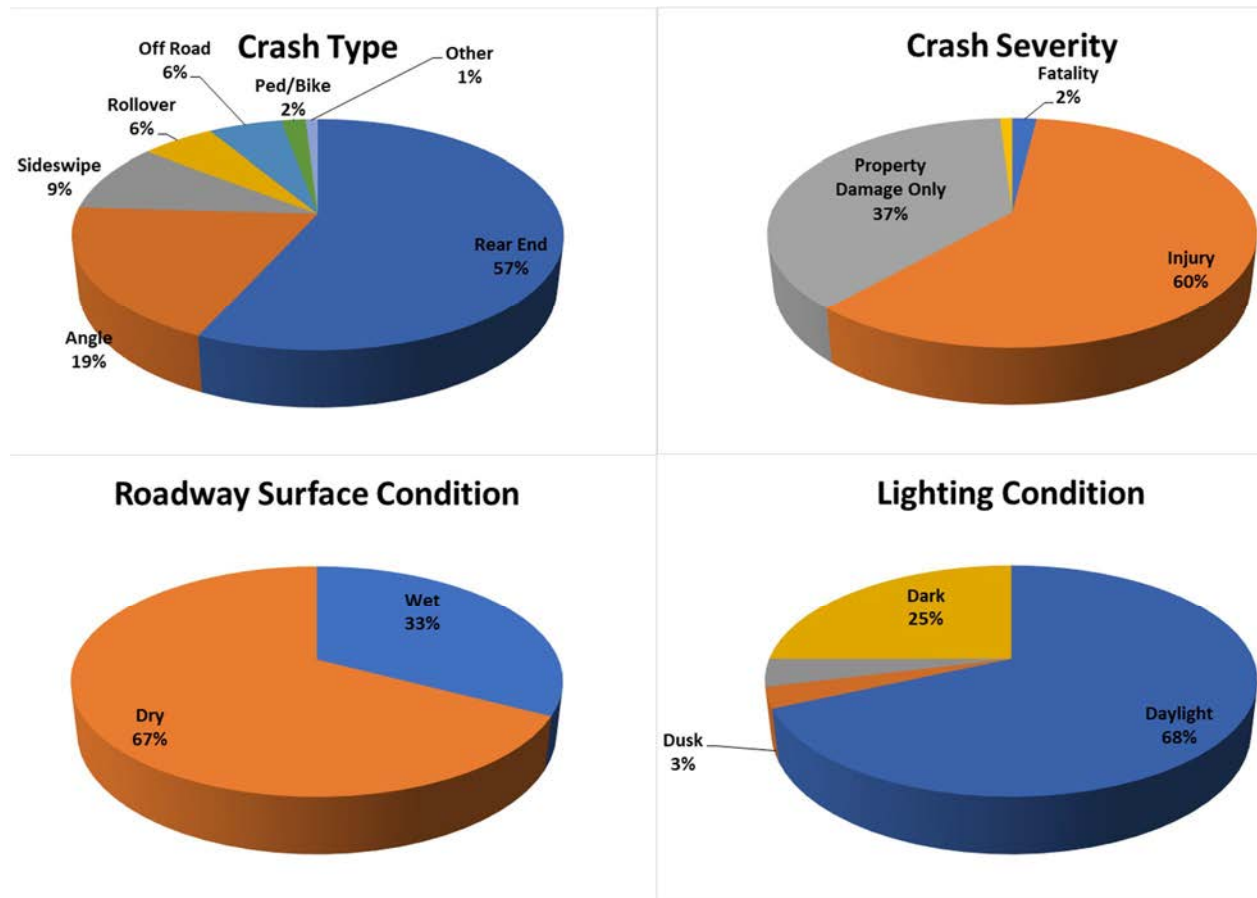


Figure 2-17 shows the crash analysis summary at arterial mid-block locations (i.e., outside the intersection influence areas) along CR 532 from 2014 through 2018. A total of 104 crashes were reported at CR 532 mid-block locations between S. Old Lake Wilson Road and US 17/US 92. Most of them were rear-end and resulted in injuries, as illustrated on Figure 2-17. There were two fatalities reported within five-years. A majority of the crashes occurred under dry pavement conditions during the day.

Figure 2-17: Crash Data Summary – CR 532 Mid-Block



Actual crash rates were computed and compared with average crash rates for similar facilities within Orange and Osceola Counties to assess the safety condition within the study area. Critical crash rates and safety ratios were also estimated. Crash rates for the freeway mainline and ramps were estimated as crashes per Million Vehicle Miles Traveled (MVMT) and for the intersections as crashes per Million Entering Vehicles (MEV). The critical crash rate is based on the average crash rate for a similar facility adjusted by vehicle exposure and a probability constant. The safety ratio represents the actual crash rate divided by the critical crash rate. If a segment has an actual crash rate higher than the critical crash rate (i.e., safety ratio > 1.0), it may have a safety deficiency. The crash rates are listed in Table 2-16.

The analysis shows that the SR 429 mainline, and Sinclair Road interchange ramps within the study area had actual crash rates lower than the critical crash rates (i.e., safety ratio < 1.0), from 2014 through 2018. I-4 mainline has safety ratio higher than 1.0 which indicates a safety deficiency. It is important to note that the segment of SR 429 and I-4 within the study limits experiences severe congestion during peak periods.



Table 2-16: Crash Rates and Safety Ratios for 2014 through 2018

Description	Total Crashes	Actual Crash Rate	Average Crash Rate*	Critical Crash Rate	Safety Ratio
<b>Freeway Mainline Or Ramps</b>					
Western Beltway Mainline	42	0.71	0.65	1.23	0.57
I-4 Mainline	1147	1.44	0.76	0.92	1.56
Sinclair Ramps	7	0.35	0.65	1.71	0.21
<b>Intersection</b>					
Sinclair Road and SR 429	9	0.37	0.69	1.68	0.22
Lake Wilson Road & CR 532	58	0.71	0.69	1.21	0.59
US 17/92 & CR 532	27	0.35	0.27	0.61	0.58
<b>Arterial Mid-block Segments</b>					
CR 532	104	0.98	0.96	1.48	0.66

\*FDOT CARS Osceola County, Five-Year Average Crash Rate

SR 429 Mainline: Toll Road Urban

SR 429 Ramps: Ramp Urban

Crash rate not available, used rate for mainline

I-4: Interstate Urban

Sinclair Road and SR 429 Ramps, Lake Wilson Road and CR 532 Intersection, US 17/92 and CR 532: Suburban 4-5 Lanes 2-Way Divided Raised

Crash Rate:

Highway/Ramps: Crashes per Million Vehicle Miles Travelled (MVMT)

Intersections: Crashes per Million Entering Vehicles (MEV)

Mid-Block: Crashes per Million Vehicle Miles Travelled (MVMT)

## 2.16 Drainage

The project is located in the northwest corner of Osceola County. The project lays within the Reedy Creek watershed, the overall drainage patterns are from north to south and west to east. Ultimately, project improvements would discharge into the following waterways: Reedy Creek, Davenport Creek, Davenport Creek Tributary 3, and Davenport Creek Tributary 4. The existing corridor is comprised of open conveyance ditches and closed collection systems to convey runoff to stormwater management systems. Most of the corridor is located along a ridge with wetlands located on the west side, therefore there is minimal offsite flow discharging directly into the existing ROW. Offsite area is conveyed through the corridor through a series of cross drains.

Soils in the project area tend to be well drained during the dry season and poorly drained as the soil becomes saturated during the wet season. Furthermore, the drainage class of the soils within the project limits between CR 532 and the I-4 Interchange are listed as "poorly drained". The soils within the interchange area and to the north along SR 429 are considered to be "excessively drained".

Nine major basins have been identified within the limits of the study area. Detailed information about the drainage basins is available in the *Pond Siting Report* available under separate cover. Basins and sub-basins have been defined to correlate with permitted conditions within the project limits. Basin and sub-basin divides have been developed utilizing existing permit information which has been supplemented with Light Detection and Ranging (LiDAR) data and information obtained during field reviews. All basins within the corridor are considered open basins.

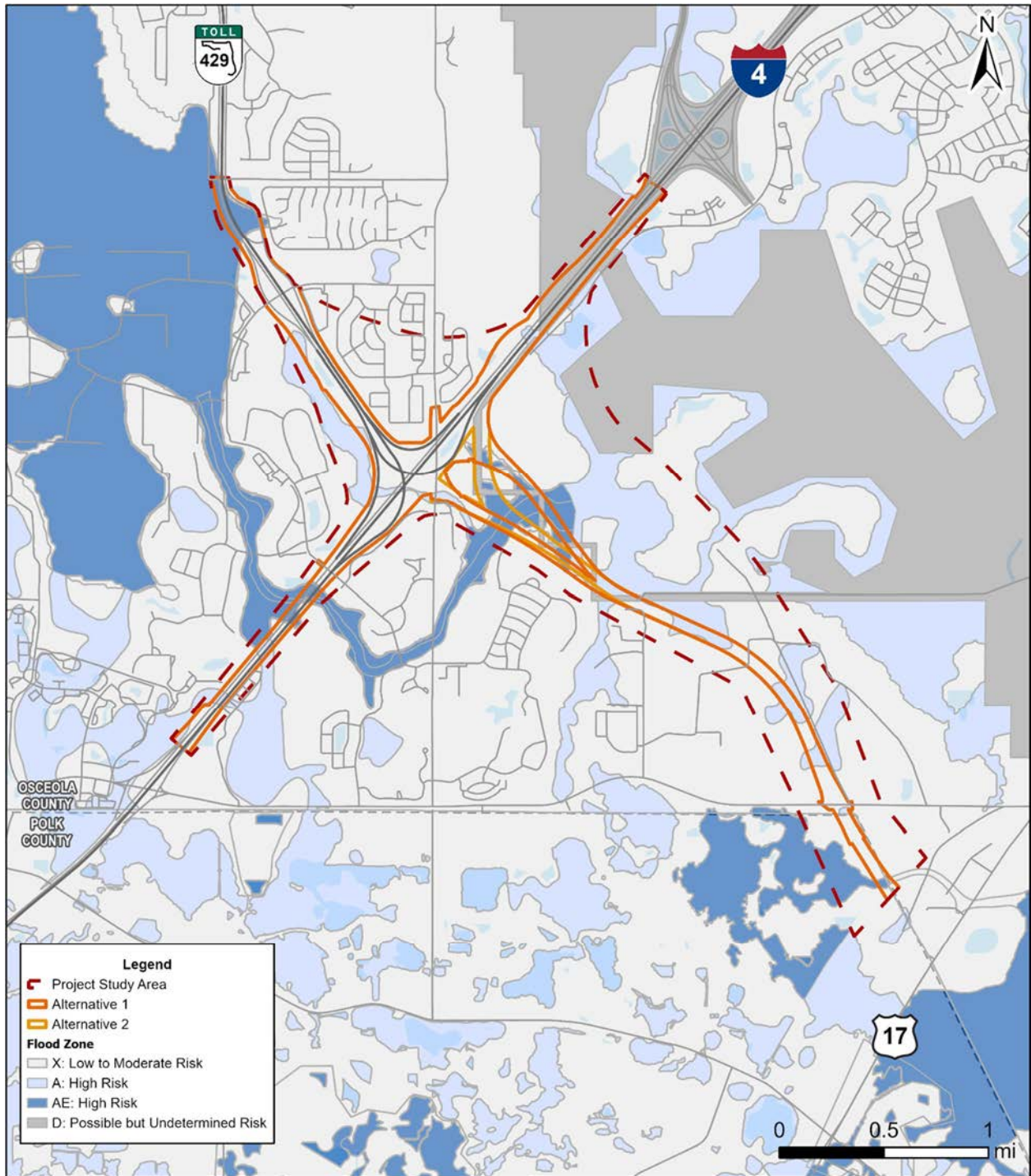
The I-4 interchange at SR 429 is a multilevel interchange with stormwater management facilities located within the infields. A combination of roadside ditches and closed collection systems convey runoff to the stormwater management facilities for treatment and attenuation (ERP Permit No. 49-187636001). Additional information regarding the existing stormwater management facilities can be found in the *Pond Siting Report* provided under separate cover.

The interchange has multiple cross drains which convey offsite flow associated with Davenport Creek and Davenport Creek Tributary 3 through the corridor. Further information can be found in the *Location Hydraulic Report* (LHR), available under separate cover. Additionally, these waterways have floodplains associated with them (Figure 2-16). Per the Flood Insurance Rate Map (FIRM) 12097C0040G dated June 18, 2013, there are Zone A and Zone AE floodplains within the project corridor. Davenport Creek also has a regulated floodway associated with the waterway.

Although project improvements will not discharge directly to any Outstanding Florida Waters (OFW's), the project is located within the Lake Okeechobee Basin Management Action Plan. The Florida Department of Environmental Protection (FDEP) has defined three Water Body Identification numbers (WBIDs) that encompass the study area. Of the three WBIDs only WBID 3170K is impaired for Bacteria (Fecal Coliform).

There is one drainage connection permit within the project corridor, TP-92-DC-180-18. This connection is for the Sinclair Road Apartments located at MP 1.5, issued in 2020.

Figure 2-18: Floodplain Map



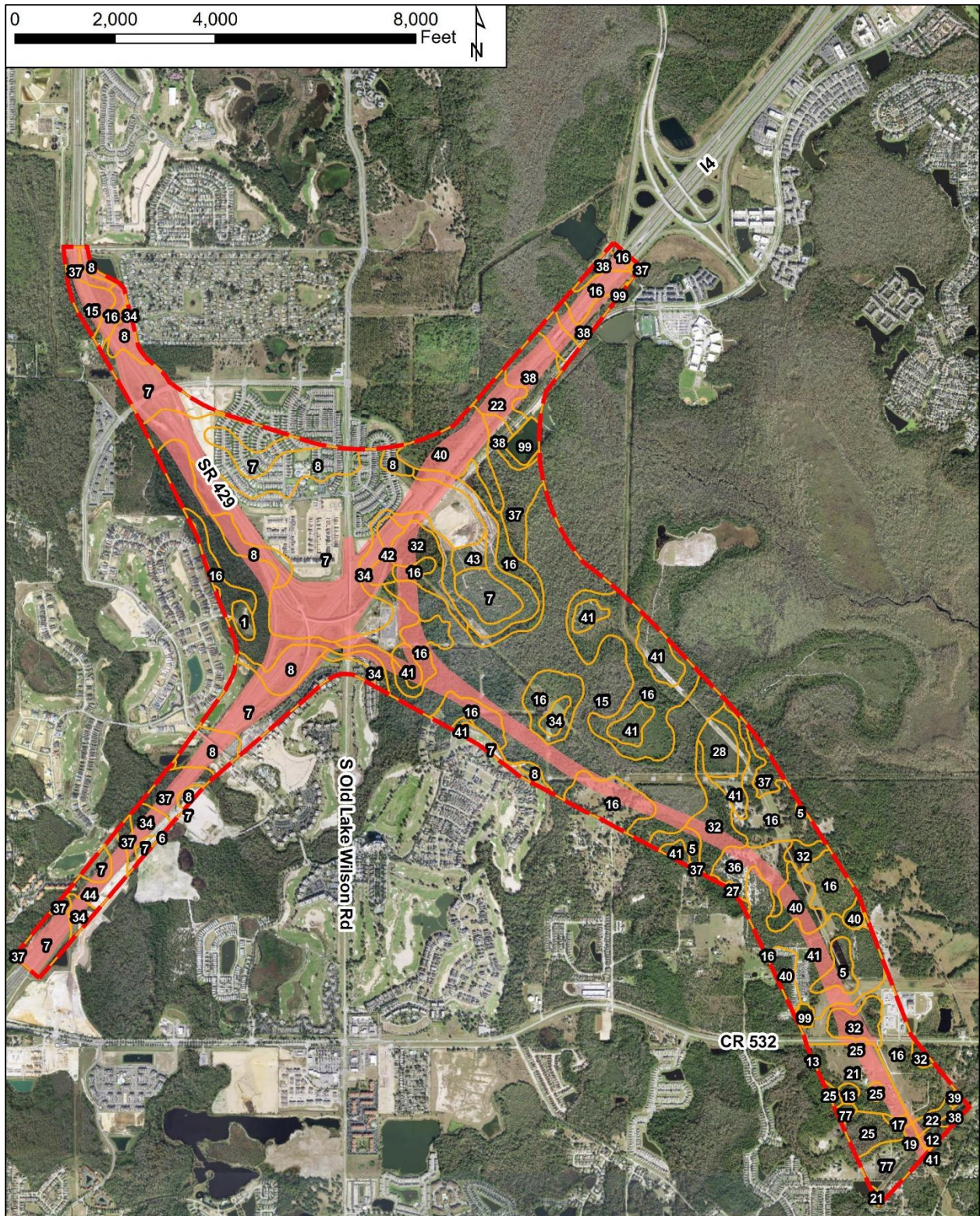
### 2.17 Soils and Geotechnical Data

Based on the *Soil Survey of Osceola County Area County, Florida* (NRCS, 1979) and the *Soil Survey of Polk County, Florida* (NRCS, 1990), the project study area is comprised of 28 soil types as listed below and illustrated in Figure 2-19. According to the *Hydric Soils of Florida Handbook* (Hurt, 2007), 20 of the soil types reported within the project study area are classified as hydric and eight are non-hydric. Of the eight non-hydric soils, three are reported as having hydric soil inclusions. Mapped hydric soils comprise 1,156.2 acres (58.4 percent) and non-hydric soils cover 811.6 acres (40.9 percent) of the project study area.

- 1: Adamsville Sand, 0 to 2 percent slopes
- 5: Basinger Fine Sand, 0 to 2 percent slopes
- 6: Basinger Fine Sand, depressional, 0 to 1 percent slopes
- 7: Candler Sand, 0 to 5 percent slopes
- 8: Candler Sand, 5 to 12 percent slopes
- 12: Floridana Fine Sand, frequently ponded, 0 to 1 percent slopes
- 13: Samsula Muck, frequently ponded, 0 to 1 percent slopes
- 15: Hontoon Muck, frequently ponded, 0 to 1 percent slopes
- 16: Immokalee Fine Sand, 0 to 2 percent slopes
- 17: Smyrna and Myakka Fine Sands
- 19: Floridana Mucky Fine Sand, frequently ponded, 0 to 1 percent slopes
- 21: Immokalee Sand
- 22: Myakka Fine Sand, 0 to 2 percent slopes
- 25: Placid and Myakka Fine Sands, depressional
- 27: Ona Fine Sand, 0 to 2 percent slopes
- 28: Paola Sand, 0 to 5 percent slopes
- 32: Placid Fine Sand, frequently ponded, 0 to 1 percent slopes
- 34: Pomello Fine Sand, 0 to 5 percent slopes
- 36: Pompano Fine Sand, 0 to 2 percent slopes
- 37: Pompano Fine Sand, frequently ponded, 0 to 1 percent slopes
- 38: Riviera Fine Sand, 0 to 2 percent slopes
- 39: Riviera Fine Sand, frequently ponded, 0 to 1 percent slopes
- 40: Samsula Muck, frequently ponded, 0 to 1 percent slopes
- 41: Satellite Sand, 0 to 2 percent slopes
- 42: Smyrna Fine Sand, 0 to 2 percent slopes
- 43: St. Lucie Fine Sand, 0 to 5 percent slopes
- 44: Tavares Fine Sand, 0 to 5 percent slopes
- 77: Satellite Sand, 0 to 2 percent slopes



Figure 2-19: Soils Map





## 2.18 Utilities

All utility marked plans and as-built information is included in the supporting *Utility Assessment Report* prepared under separate cover and located in the project file.

### 2.18.1 Utility Coordination

The preliminary utility coordination and investigation effort was conducted through written and verbal communications with the existing utility owners. A Sunshine State 811 of Florida Design Ticket System listing of existing utility owners was acquired on January 29, 2020.

Initially, verbal communication was made to all utility owners outlining the investigation effort along with the project limits. The list of utility agencies owners (UAO) known to operate utilities within the project corridor is provided in Table 2-17.

For the report's preparation, utility owners were provided aerial based utility plans depicting the Poinciana Parkway (SR 538) between the planned terminus at CR 532 to the I-4/SR 429 interchange. Using these aerial plans as a base map, each utility owner was asked to indicate their existing and proposed utilities as well as any easements that may affect their reimbursement rights for potential relocations of their facilities. In response, most utility owners replied via written communications. The utility owners provided the requested information concerning their facilities using either the utility plans or reference documentation (i.e., "As Built" or GIS maps). "Marked" Plans or reference documentation received from the Utility Agency Owners is listed in Section 2.18.2.

Table 2-17: Utility Contact Information

Utility Agency	Contact Name	Contact Phone	Contact Email
Bright House Networks	John Smith (Smitty)	407-448-5513	<a href="mailto:john.smith5@charter.com">john.smith5@charter.com</a>
CenturyLink	Eric Walls	407-907-9284	<a href="mailto:ewalls@terratechllc.net">ewalls@terratechllc.net</a>
CenturyLink fka Level 3	Xan Rypkema	720-888-1089	<a href="mailto:xan.rypkema@lumen.com">xan.rypkema@lumen.com</a>
ComCast	N/A	N/A	<a href="mailto:cenflr-nfl_construction@comcast.com">cenflr-nfl_construction@comcast.com</a>
Duke Energy Distribution	Mark Manner	963-241-1663	<a href="mailto:mark.manner@duke-energy.com">mark.manner@duke-energy.com</a>
Duke Energy Transmission	Aric Rogers	813-909-1245	<a href="mailto:arogers@pike.com">arogers@pike.com</a>
Duke Energy Fiber	Julian Jordan	727-820-5208	<a href="mailto:julian.jordan@duke-energy.com">julian.jordan@duke-energy.com</a>
Enterprise Community Development	Gregory Kolb	404-423-8398	<a href="mailto:g.kolb@gaiconsultants.com">g.kolb@gaiconsultants.com</a>
Florida Gas Transmission	Joseph Sanchez	407-838-7171	<a href="mailto:joseph.e.sanchez@energytransfer.com">joseph.e.sanchez@energytransfer.com</a>
Florida Southeast Connection	Segun Ojetayo	713-951-5379	<a href="mailto:Segun.ojetayo@nexteraenergy.com">Segun.ojetayo@nexteraenergy.com</a>
Gulfstream Natural Gas	Fred DeLoach	941-723-7108	<a href="mailto:Fred.deloach@williams.com">Fred.deloach@williams.com</a>
Kinder Morgan	Joe Pedraza	713-420-6250	<a href="mailto:Jose_pedraza2@kindermorgan.com">Jose_pedraza2@kindermorgan.com</a>
Kissimmee Utility Authority Electric	Felix Escobar	407-933-7777 ext.6600	<a href="mailto:fescobar@kua.com">fescobar@kua.com</a>
Kissimmee Utility Authority/Transtate Industrial Pipeline	Tom Ulmer	772-778-2255	<a href="mailto:tulmerjr@transtate.com">tulmerjr@transtate.com</a>
Osceola County Traffic	Jack Lott	407-742-7534	<a href="mailto:Jack.lott@osceola.org">Jack.lott@osceola.org</a>
Polk County	Chris Lyon	863-534-4027	<a href="mailto:chrislyon@polkgov.net">chrislyon@polkgov.net</a>
Spectra Energy-Sabal Trail	Peter Kerrigen	407-966-2928	<a href="mailto:Peter.kerrigen@enbridge.com">Peter.kerrigen@enbridge.com</a>
Summit Broadband	Michelle Daniel	407-996-1183	<a href="mailto:mdaniel@summit-broadband.com">mdaniel@summit-broadband.com</a>
TECO Peoples Gas	Shawn Winsor	407-420-6663	<a href="mailto:swinsor@tecoenergy.com">swinsor@tecoenergy.com</a>
TOHO Water Authority	Robert Pelham	407-944-5132	<a href="mailto:rpelham@tohowater.com">rpelham@tohowater.com</a>
Uniti Fiber	James Mosley	251-645-8216	<a href="mailto:James.mosley@uniti.com">James.mosley@uniti.com</a>
Verizon	Tim Cole	407-618-2078	<a href="mailto:Timothy.cole@verizon.com">Timothy.cole@verizon.com</a>
Zayo	Bruce Herrington	813-386-2927 x2927	<a href="mailto:bruce.herrington@kci.com">bruce.herrington@kci.com</a>

### *2.18.2 Existing Utility Facilities*

#### Bright House Networks

No response

#### CenturyLink

No response

#### CenturyLink fka Level 3

No Facilities e-mail received from Eric Walls on 9/8/2021.

#### ComCast

No response

#### Duke Energy Distribution

Duke Energy Distribution owns, maintains, and operates facilities throughout all the project limits both aerial and underground. They have a 12.47kv overhead facilities that run north and south along Old Wilson Road on the east side. They have underground phase I lines that feed the lighting throughout project limits. There was no estimate given for reimbursement.

#### Duke Energy Transmission

No response

#### Duke Energy Fiber

No response

#### Florida Gas Transmission

No response but meeting held on January 31, 2022

#### Florida Southeast Connection

No response

#### Gulfstream Natural Gas

Gulfstream Natural Gas owns operates and maintains a 16-inch and 24-inch-high pressure transmission pipeline within the project limits. At SR 429 and I-4 there is a Meter station 456, 457, and 458 and Radio Tower on the East side of I-4. There is a 24-inch Steel Natural Gas Transmission pipeline that runs along the back side of the meter station and runs parallel to I-4. Gulfstream is within an easement area and will be requesting for reimbursement on this project. Gulfstream did not provide a cost estimate at this time.

#### Kinder Morgan

No response

#### Kissimmee Utility Authority (KUA) Natural Gas

KUA has a gas main that runs from the south along S. Old Lake Wilson to the north and goes into the meter station.



Osceola County

No Facilities e-mail received on 08/31/2021 from Jack Lott.

Polk County

No response

Sabal Trail

No response

Summit Broadband

Summit Broadband has existing fiber optic cable (FOC) that runs from the south to the north along S. Old Lake Wilson Road and then turns and goes east to the meter station.

They also have 3-1¼-inch conduit with a 72ct FOC that runs from the north along on the ramp to I-4 and then turns and crosses I-4 and follows the on ramp to SR 429 on the south side and continues east.

TECO Peoples Gas

TECO Peoples Gas has facilities along S. Old Lake Wilson Road.

TOHO Water Authority

No response

Uniti Fiber

Uniti Fiber has 2-1¼-inch ducts with ¾-inch fiber cable that runs along S. Old Lake Wilson on the east side and turns and goes into the meter station.

Verizon

No response

Zayo

Zayo has 3-1¼"-inch HDPE ducts that run along S. Old Lake Wilson on the east side.

## 2.19 Lighting

The existing lighting within the study area is summarized in Table 2-18.

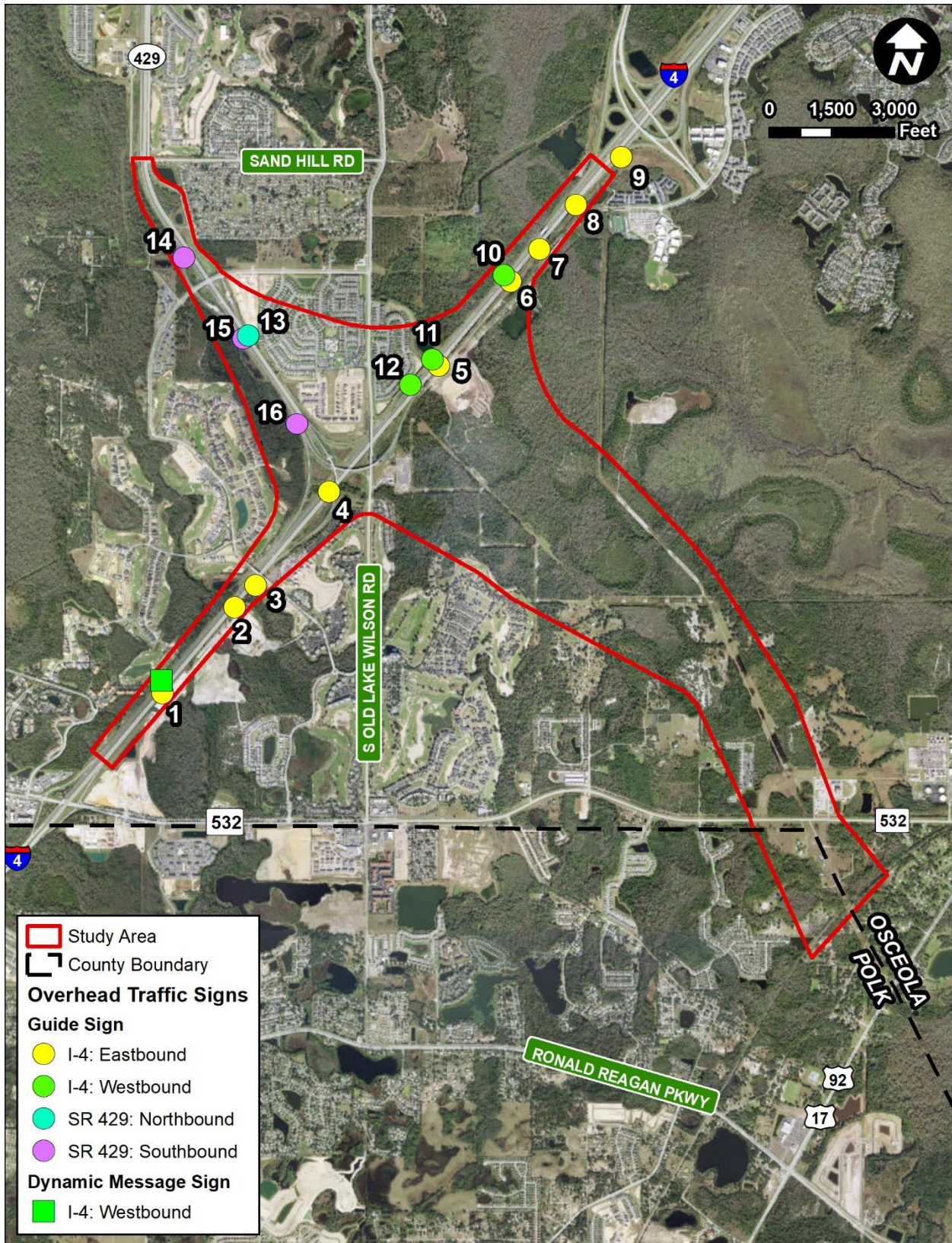
Table 2-18: Existing Lighting

Location	Type	Comment	Maintaining Agency
SR 429	Conventional	Within Sinclair Road and I-4 interchange areas	FDOT
I-4	Conventional	Within the World Drive and SR 429 interchange areas	FDOT
I-4	High Mast	Within the CR 532 interchange area	FDOT
CR 532	None	Conventional lighting is planned with the programmed CR 532 widening	Osceola County
Sinclair Road	Decorative		
Sand Hill Road	None		
Connector Road	None		
S. Old Lake Wilson Road	None		

## 2.20 Signs

Major overhead traffic signs are located on I-4 and SR 429 and are illustrated on Figure 2-18. Traffic signs along other roadways in the study area are consistent with typical signage on similar facilities. Regulatory, warning, and guide signs are located throughout the study area.

Figure 2-18: Overhead Traffic Signs





The following guide signs along I-4 and SR 429 correspond with the labeled numbers on Figure 2-18:

1. 

EXIT 60  
TOLL 429 NORTH  
Apopka  
3/4 MILE
2. 

EXIT 60  
TOLL 429 NORTH  
Apopka  
1/4 MILE
3. 

EXIT 60  
TOLL 429 NORTH  
Apopka ↗
4. 

EXIT 62  
TOLL 417 NORTH  
✈ Int'l Airport  
Sanford  
1 3/4 MILES



EXIT 62  
Disney World  
Celebration  
1 3/4 MILES
5. 

EXIT 62  
TOLL 417 NORTH  
✈ Int'l Airport  
Sanford  
1 MILE



EXIT 62  
Disney World  
Celebration  
1 MILE
6. 

EXIT 62  
TOLL 417 NORTH  
✈ Int'l Airport  
Sanford  
1/2 MILE



EXIT 62  
Disney World  
Celebration  
1/2 MILE





### 2.21 Aesthetics Features

The topography of the project study area is relatively flat consisting primarily of single- and multi-family residential use, along with single-story commercial buildings. A considerable amount of landscaping has been installed at the I-4/SR 429 and SR 429/Sinclair Road interchanges. This area has been identified as a gateway to the Disney attractions and major tourist destinations. Landscaping has also been installed at the I-4 and CR 532 interchange and along CR 532, from I-4 to S. Old Lake Wilson Road.

### 2.22 Bridges and Structures

There are seven existing bridges within the project limits. Bridge information pertinent to the study was compiled from as-built construction plans, inspection reports, and load ratings (see Table 2-19). Four bridges are owned by FTE, two bridges are owned by FDOT District Five, and one bridge is privately owned. Three bridges utilize concrete beam superstructures, two bridges utilize steel plate girders, and two bridges utilize steel box girders. No bridges within the project limits are classified as structurally deficient.

For bridge crossings over roadway facilities, the Florida Design Manual (FDM) specifies a minimum vertical clearance of 16.5 feet for new bridges and 16 feet for construction affecting existing



bridges. All bridges crossing roadway facilities within the project limits satisfy minimum vertical clearance requirements.

There is one box culvert crossing below FTE facilities, three box culverts crossing below FDOT District Five facilities, and one arched culvert crossing below Osceola County facilities within the project study area (see Table 2-20). Three of the culverts are from the original I-4 construction through the area, built in 1960, and have since been widened. One box culvert was constructed when the I-4/SR 429 interchange was constructed in 2006. One bridge culvert is a Conspan arch bridge culvert that carries CR 545 (S. Old Lake Wilson Road) over a golf cart path. Four culverts have Health Index scores less than 75, with the lowest score being 34.61. Sufficiency ratings are provided in the Table 2-20.

Table 2-19: Existing Bridge Structures

Structure Number	Description	Owner	Overall Length (ft)	Out-to-Out (ft)	Cross-Slope (%)	Skew (deg)	No. of Lanes (Total)	Load Rating	Sufficiency Rating	Health Index	Year Built/Widened	Vertical Clearance from Plans	Vertical Clearance from IR	Superstructure Type	Substructure Type	Foundation Type	Design Vehicle	Design Speed (Per Plans)	Existing Barrier Type(s)	Bridge Deck Grooving (Y or N)
920607	Sinclair Road over SR 429	Osceola County	198'	93'-9"	NC	7.7	4	1.37 (HS 20)	100	99.57	2004	16'-9 5/8"	17.5'	AASHTO Type IV Beams	Piers	18" Sq. PSC Piles	HL-93	45 mph	27" Parapet with Fencing/32" F-Shape	Y
925500	Tradition Boulevard over I-4	Private	402'	46'-0"	2.00	0	2	1.09 (HS 20)	88.6	99.8	2005	22'-1"	23.1'	Steel Plate Girders	Piers	HP 14x73 Steel H-piles	HS 20-44	35 mph	27" Parapet with Fencing/32" F-Shape	Y
920601	Eastbound I-4 to Northbound SR 429 Ramp (Ramp B) over I-4 & Ramp C	FTE	1037'-11 1/8"	49'-1"	7.50	0	1	1.11 (HS 20)	99.1	95.6	2006	16'-8 3/4"	17'	Steel Box Girders	Piers	24" Sq. PSC Piles	HS 20-44	50 mph	32" F-Shape	Y
920602	Southbound SR 429 to Eastbound I-4 Ramp (Ramp C) over I-4 & CR 545	FTE	1167'-9 7/16"	49'-1"	8.40	0	1	1.04 (HS 20)	99.3	99.01	2006	17'-6 1/2"	18.58'	Steel Box Girders	Piers	18" Sq. PSC Piles	HS 20-44	50 mph	32" F-Shape	Y
920603	Southbound SR 429 over Sand Hill Road	FTE	70'-8 3/16"	49'-1"	7.00	4.334	2	1.01 (HS 20)	99.4	99.73	2006	19'-1"	19.42'	AASHTO Type III Beams	Pile End Bents	18" Sq. PSC Piles	HS 20-44	70 mph	32" F-Shape	Y
920604	Northbound SR 429 over Sand Hill Road	FTE	70'-8 3/16"	45'-1"	7.00	4.334	2	1.13 (HS 20)	99.4	99.82	2006	16'-7"	16.6'	AASHTO Type III Beams	Pile End Bents	18" Sq. PSC Piles	HS 20-44	70 mph	32" F-Shape	Y
924179	CR 545 (S. Old Lake Wilson Road) over I-4	Osceola County	880'	43'-1"	2.00	50.09	2	1.30 (HS 20)	96.5	99.73	2005	17'-6" (over future ult.)	21'	Steel Plate Girders	Piers	18" PSC Piles	HS 20-44	55 mph	32" F-Shape	Y

Table 2-20: Existing Box Culverts

Structure Number	Location	Owner	Number of Cells	Length	Cell Opening		Facility Carrying/ Crossing	Year Built	Sufficiency Rating	Health Index	Work Recommendations from Inspection Report	Date of Inspection Report
					Height	Width						
920097	1.3 miles North of Polk County Line	FDOT D5	4	279.5'	8'-0"	12'-0"	SR 400 (I-4) over Davenport Creek	1960 (widened in 2021)	70	66.96	No Recommendations from Inspection Report	5/9/2022
920202	0.8-mile East of CR 532	FDOT D5	2	265'	7'-0"	9'-0"	SR 400 (I-4) over Ditch	1960 (widened in 2002)	59	34.61	Remove vegetation from both ends of the culvert. Remove vegetation covering wingwalls.	10/25/2022
920203	2.0 miles North of Polk County Line	FDOT D5	2	308'	4'-0"	7'-0"	SR 400 (I-4) over Ditch	1960 (widened in 2006)	70	36.42	Remove heavy vegetation growth at both sides of the culvert. Fill and stabilize area of erosion adjacent to the end of the southwest wing wall. Patch spall with exposed steel at south headwall, Barrel 1 Wall 1, and Barrel 2 Wall 3. Repair the void with moderate active backfill leakage in Barrel 2 Wall 3. Clean and seal cracks and spalls at the construction joints.	8/23/2021
925501	0.4-mile South of I-4	Osceola County	1	137'	10'-8"	24'-0"	CR 545 over Golf Cart Crossing #2	2005	97	88.09	Pressure wash and clean the arch crest underside and cart pathway. Repair spall and delamination in the underside of Segment 13.	10/7/2020
92Q038	SR 429 Southbound Ramp A to SR 400 (I-4) Westbound	FTE	2	90'	4'-0"	7'-0"	SR 429 Southbound Ramp A over Ditch	2006	100	67.69	No Recommendations from Inspection Report	2/14/2019

## 3.0 PROJECT DESIGN CONTROLS & CRITERIA

### 3.1 Roadway Context Classification

The FDOT does not assign a context classification to SR 429, I-4, or Poinciana Parkway (SR 538). Other roads in the study area, including Sinclair Road, CR 532 and S. Old Lake Wilson Road, are non-state facilities and the maintaining agency (Osceola County) has not established a context classification for these roadways.

### 3.2 Design Control and Criteria

The design criteria and standards are based on design parameters outlined in A Policy on Geometric Design of Highways and Streets (AASHTO, 2011), FDOT Design Manual (FDM) (FDOT, 2022), SFWMD Environmental Resource Permit (ERP) Applicant's Handbook, Volume II, Load Rating Manual (FDOT, 2022), and Load and Resistance Factor Design (LRFD) Bridge Design Specifications (AASHTO, Eighth Edition and 2018 Interims). Table 3-1 lists the design criteria established for the project.

Table 3-1: Design Control Criteria

Design Element	Design Standard	Source
General Criteria		
Design Standard Manual	2022 FDOT Design Manual (FDM)	
Design Vehicle:	WB-62 FL	FDM Section 201.6
Functional Classification	Principal Arterial Expressway	FDOT Straight-Line Diagrams (SLDs)
Design Speed		FDM Table 201.5.1
Mainline	70 mph	
Ramps		FDM Table 201.5.2
<ul style="list-style-type: none"> <li>• Loop and Semi-Direct</li> <li>• Outer Cloverleaf</li> <li>• Intermediate Portions of Long Ramps</li> <li>• Direct Connections</li> </ul>	30 mph 35 mph 40 mph 50 mph	
Horizontal Geometry Criteria		
Lane Width		
Mainline	12 feet (mainline)	FDM Section 211.2
Ramps		
<ul style="list-style-type: none"> <li>• One-lane</li> <li>• Two-lane (+)</li> </ul>	15 feet (one-lane ramp) 24 feet (two-lane ramp)	FDM Section 211.2.1 FDM Section 211.2.1
Shoulder Width		
Mainline		
<ul style="list-style-type: none"> <li>• Two-lane</li> </ul>	8 feet inside/ 12 feet outside	FDM Table 211.4.1

Design Element	Design Standard	Source
<ul style="list-style-type: none"> <li>• Three-lane or more</li> </ul> <p>Ramps</p> <ul style="list-style-type: none"> <li>• One-lane</li> <li>• Two-lane Non-Interstate</li> <li>• Two-lane Interstate</li> </ul>	<p>12 feet inside and outside</p> <p>6 feet inside and outside</p> <p>8 feet inside/10 feet outside</p> <p>8 feet inside/12 feet outside</p>	<p>FDM Table 211.4.1</p> <p>FDM Table 211.4.1</p> <p>FDM Table 211.4.1</p> <p>FDM Table 211.4.1</p>
<p>Median Width</p>	<p>26 feet (with barrier)</p> <p>60 feet (w/o barrier, Design Speed ≥ 60 mph)</p> <p>64 feet (Interstate, w/o barrier)</p>	<p>FDM Table 211.3.1</p>
<p>Border Width</p>	<p>94 feet (new construction)</p> <p>10 feet (minimum for maintenance in conjunction with roadside barriers)</p>	<p>FDM Section 211.6.1</p>
<p>Lateral Offset</p>	<p>Light Poles</p> <ul style="list-style-type: none"> <li>• Conventional: 20 feet from Travel Lane, 14 feet from Auxiliary Lane, or Clear Zone width, whichever is less</li> <li>• High Mast: Outside Clear Zone</li> </ul> <p>Signal Poles and Controller Cabinets</p> <ul style="list-style-type: none"> <li>• Outside Clear Zone</li> </ul> <p>ITS Poles and Related Items</p> <ul style="list-style-type: none"> <li>• Pole &amp; Other Aboveground Fixed Object: Outside Clear Zone</li> <li>• Equipment Shelters and Towers: Outside limited access right of way.</li> <li>• Breakaway Objects: As Close to R/W As Possible</li> </ul> <p>Traffic Control Signs</p> <ul style="list-style-type: none"> <li>• Overhead Sign Structures: Outside Clear Zone</li> </ul> <p>Trees</p> <ul style="list-style-type: none"> <li>• Outside Clear Zone</li> </ul>	<p>FDM Table 215.2.2</p>

Design Element	Design Standard	Source
	<p>Aboveground Utilities</p> <ul style="list-style-type: none"> <li>• Existing Utilities: Outside Clear Zone</li> <li>• New or Relocated Utilities: Outside Clear Zone</li> </ul> <p>Roadways Overpassing Railroads</p> <ul style="list-style-type: none"> <li>• Place edges of footings no closer than 11 feet from centerline of the track to provide adequate room for sheeting.</li> </ul> <p>Canal and Drop-off Hazards</p> <ul style="list-style-type: none"> <li>• Not less than 60 feet for flush shoulder and curbed roadways with design speeds of 50 mph or greater.</li> </ul> <p>Bridge Piers and Abutments</p> <ul style="list-style-type: none"> <li>• Outside Clear Zone</li> </ul> <p>Rigid Barrier Minimum Setback Distance</p> <ul style="list-style-type: none"> <li>• Concrete Barrier ≥ 40" Height: 0 feet, 0 inches</li> <li>• Bridge Traffic Railing: 5 feet, 0 inches</li> </ul>	<p>FDM 220.3.2.3</p> <p>FDM 215.3.2</p> <p>FDM Table 215.2.2</p> <p>FDM Table 215.4.2</p>
<p>Clear Zone Width</p>	<p>Design Speed ≥ 60 mph</p> <ul style="list-style-type: none"> <li>• 36 feet (travel lanes and multilane ramps)</li> <li>• 24 feet (auxiliary lanes and single lane ramps)</li> </ul> <p>Design Speed = 55 mph</p> <ul style="list-style-type: none"> <li>• 30 feet (travel lanes and multilane ramps)</li> <li>• 18 feet (auxiliary lanes and single lane ramps)</li> </ul> <p>Design Speed = 45-50 mph</p> <ul style="list-style-type: none"> <li>• 24 feet (travel lanes and multilane ramps)</li> <li>• 14 feet (auxiliary lanes and single lane ramps)</li> </ul>	<p>FDM Table 215.2.1</p>

SECTION 3 – PROJECT DESIGN CONTROLS & CRITERIA

Design Element	Design Standard	Source
	Design Speed = 40 mph <ul style="list-style-type: none"> <li>• 18 feet (travel lanes and multilane ramps)</li> <li>• 10 feet (auxiliary lanes and single lane ramps)</li> </ul> Design Speed = 35 mph <ul style="list-style-type: none"> <li>• 14 feet (travel lanes and multilane ramps)</li> <li>• 10 feet (auxiliary lanes and single lane ramps)</li> </ul>	
Rate of Superelevation	0.10 (maximum)	FDM Section 210.9
Minimum Curve Radius	Mainline (70 mph) 1,637 feet	FDM Table 210.9.1
Length of Horizontal Curve	Mainline (70 mph) <ul style="list-style-type: none"> <li>• 2,100 feet (desirable)</li> <li>• 1,050 feet (minimum)</li> </ul> Ramp (50 mph) <ul style="list-style-type: none"> <li>• 1,500 feet (desirable)</li> <li>• 750 feet (minimum)</li> </ul> Ramp ( $\leq 45$ mph) <ul style="list-style-type: none"> <li>• 400 feet (minimum)</li> </ul>	FDM Table 211.7.1
Maximum Deflection without Curve	$2^{\circ} 00' 00''$ ( $\leq 40$ mph) $0^{\circ} 45' 00''$ ( $\geq 45$ mph)	FDM Section 211.7.1
Maximum Deflection through Intersection	$16^{\circ} 00'$ ( $\leq 20$ mph) $11^{\circ} 00'$ (25 mph) $8^{\circ} 00'$ (30 mph)	FDM Table 212.7.1
Maximum Deflection through Intersection	$6^{\circ} 00'$ (35 mph) $5^{\circ} 00'$ (40 mph) $3^{\circ} 00'$ (45 mph)	FDM Table 212.7.1
Auxiliary Lane Minimum Acceleration Length	580 feet	Policy on Geometric Design (AASHTO, Table 10-3)
Auxiliary Lane Drop	500 – 2,500 feet	Policy on Geometric Design (AASHTO, Figure 10-52)
Vertical Geometry Criteria		
Stopping Sight Distance Interstate	861 feet (70 mph, 3% Down) 780 feet (70 mph, 3% up)	FDM Table 211.10.1 FDM Table 211.10.1

SECTION 3 – PROJECT DESIGN CONTROLS & CRITERIA

Design Element	Design Standard	Source
Expressway/ Ramps	464 feet (50 mph, 5% Down) 393 feet (50 mph, 5% Up)	FDM Table 211.10.2 FDM Table 211.10.2
Maximum Profile Grade Limited Access Facilities Ramps	3% (70 mph) 5% (50 mph)	FDM Table 211.9.1 FDM Table 211.9.1
Minimum Length of Vertical Curve	Sag = 800 feet Crest (open highway) = 1,000 feet Crest (within interchanges) = 1,800 feet	FDM Table 211.9.3
Crest Vertical Curve (K- Value) Interstate (70 mph)  Ramps (50 mph)	506 (new construction) 312 (resurfacing)  136 (new construction) 84 (resurfacing)	FDM Table 211.9.2
Sag Vertical Curve (K- Value) Interstate (70 mph)  Ramps (50 mph)	206 (Interstate)  96 (Ramps)	FDM Table 211.9.2
Maximum Change in Grade without Vertical Curve	0.20 (70 mph) 0.60 (50 mph)	FDM Table 210.10.2
Vertical Clearance New Roadway Bridges  Existing Roadway Bridges  New Overhead Sign Structures  Existing Overhead Sign Structures  New Dynamic Message Sign (DMS)  Existing DMS  New Signals  Existing Signals	16.5 feet  16.0 feet  17.5 feet  17.0 feet  19.5 feet  19.0 feet  17.5 feet  17.0 feet	FDM Table 260.6.1 FDM Section 210.10.3
Base Clearance	3 feet minimum from bottom of roadway base course to water elevation.	FDM Section 210.10.3



SECTION 3 – PROJECT DESIGN CONTROLS & CRITERIA

Design Element	Design Standard	Source
	A reduction for Ramps and certain Classification types is outlined in the requirements.	
Stormwater Management Criteria		
Water Quantity	Wet detention: First 1-inch of total runoff from developed project or 2.5-inches of runoff from impervious area, whichever is greater.	SFWMD Handbook Vol. II
Water Quality*  *- RCID has more stringent requirements, see Pond Siting Report for detailed information.	Open Basins: Post development flow must not exceed pre-development peak discharge for the 25-yr/72-hr storm. RCID design event is the 50-yr/72-hr storm.  Closed Basin: Post development flow must not exceed pre-development peak discharge for the 100-yr/72-hr storm.	SFWMD Handbook Vol. II

## 4.0 ALTERNATIVES ANALYSIS

### 4.1 Previous Planning Studies

The Poinciana Parkway (SR 538) project has been envisioned for many years going back to 1992 when it was included in a Disney permit.

In December 2005, Osceola County adopted a Comprehensive Plan proposing several new corridors to meet the County's anticipated growth, including Poinciana Parkway (referred then as Parker Highway) extending north to US 17/92.

In 2008, the Orlando-Orange County Expressway Authority (OOCEA) completed a Concept Development and Evaluation Study for the SR 417 Southern Extension. This study evaluated a new expressway from SR 417, in the vicinity of the Orlando International Airport, south and then west to I-4 with connections to I-4 at SR 429, east of US 27, and west of US 27.

In 2010, the OCX formed and began creating its first long-range expressway plan. In May of 2012, OCX adopted the OCX Master Plan 2040, which included Poinciana Parkway, extending from Cypress Parkway to I-4. In 2013, OCX completed a Preliminary Alignment and Feasibility Study for Poinciana Parkway, from Poinciana Parkway to SR 429/I-4. The objective of this study was to narrow the envelope for this facility as identified in the OCX Master Plan 2040, which resulted in two options for connecting with I-4, one at SR 429 and one at CR 532.

In 2013, FDOT District Five initiated a PD&E Study for the Poinciana Parkway Extension/I-4 Connector which involved constructing an expressway from the northern terminus of the existing Poinciana Parkway to I-4. Study meetings were held with an Agency Project Advisory Group in 2013, 2014, and 2015. A public meeting was also held in June 2015. This study concluded with an Alternative Corridor Evaluation Report completed in November 2015 which documented recommendations for advancing two corridors for further study. These were: Corridor 2A which would connect to I-4 at a modified I-4/SR 429 interchange via a new corridor, and Corridor 3 which would connect to I-4 at a modified I-4/CR 532 interchange via the existing CR 532 corridor. A corridor on new alignment would provide connection from the Poinciana Parkway to CR 532.

A Concept, Feasibility, and Mobility (CF&M) Study for the Poinciana Parkway Extension/I-4 Connector was completed by CFX in May 2018. The Poinciana Parkway Extension/I-4 Connector would be a tolled expressway improvement project that includes widening the existing Poinciana Parkway to four lanes and extending it to I-4 (from Cypress Parkway to I-4). The general objective of that CF&M Study was to provide information necessary for CFX to decide on the viability of the project. The project was determined to be financially feasible and viable; therefore, CFX authorized the Poinciana Parkway Extension PD&E Study, which extended Poinciana Parkway to CR 532. This segment is currently in design by CFX and programmed for construction.

## 4.2 No-Build (No-Action) Alternative

The No-Build Alternative assumes that the extension of Poinciana Parkway (SR 538) to I-4 and the widening of SR 429 from I-4 to north of Sinclair Road is not constructed. Only those other projects included in the MPO Cost Feasible 2045 Metropolitan Transportation Plan were assumed to be provided to meet the transportation need. The results of the No-Build Alternative analysis formed the basis of the comparative analysis for the Build Alternatives.

The advantages of the No-Build Alternative include:

- No impact to adjacent social, cultural, natural, or physical environments
- No utility impacts
- No expenditure of funds for ROW acquisition, design, or construction

The disadvantages of the No-Build Alternative include:

- Does not provide system-to-system connectivity between Poinciana Parkway (SR 538) and I-4/SR 429
- Retains a missing segment of the regional expressway system in Osceola County
- Does not address vehicular travel demands
- Does not alleviate traffic on segments of CR 532 and I-4
- Rate of crashes in the study area would likely continue to increase

The No-Build Alternative will remain viable throughout the PD&E Study.

## 4.3 Transportation Systems Management & Operations Alternative (TSM&O)

The TSM&O Alternative considers safety and minor operational improvements to existing facilities that may include additional turn lanes, intersection improvements, traffic signal optimization, intelligent transportation systems (ITS) technology implementation, and/or pavement marking improvements to enhance safety and mobility. No TSM&O Alternative can fulfill the purpose and need for the project; therefore, no TSM&O options were identified for the study. The primary purpose and need is to provide system linkage and accommodate transportation demands. As the TSM&O Alternative would only provide safety and minor operational improvements, a gap would remain in the regional beltway around Orlando.

## 4.4 Future Conditions

Future lane requirements were evaluated to provide an estimated timeline for the onset of capacity deficiencies along the freeway mainline and ramp roadways. Freeway mainline capacity evaluation was based on the 2020 FDOT Quality and LOS Handbook target volumes. Capacity analysis for ramp roadways was based on targets from the Highway Capacity Manual (HCM).

To meet LOS D, the analysis shows that the SR 429 mainline will require three lanes of travel by year 2032 and four lanes by 2048 between Sinclair Road and I-4. The proposed Poinciana Parkway (SR 538) segments south of I-4 will require two lanes of travel per direction through the 2050

Design Year. Lane requirements for the SR 429 mainline do not change based on LOS E capacity targets; however, the year of need is delayed by two to three years compared to LOS D maximum service volume constraints. Three lanes per direction will be required by 2033 and 2035, north and south of Sinclair Road, respectively. Whereas four lanes will be required by 2050, north of Sinclair Road. Similar to LOS D analysis, only two lanes of travel per direction will be required through 2050 on the proposed Poinciana Parkway (SR 538) segments south of I-4.

Most of the ramp roadways within the study limits will require one lane through the 2050 Design Year, except for the ramps to and from the north at SR 429 which will need two lanes each by year 2030 and three lanes by 2041.

#### 4.5 Build Alternative(s)

Two Build Alternatives were evaluated (Figure 4-1 and Figure 4-2). Both alternatives are identical except for differences at the Poinciana Parkway (SR 538)/I-4/SR 429 interchange. Below is a summary of the alternatives considered by segment and interchange:

- Poinciana Parkway (SR 538) Typical Section
  - Six lane typical section consisting of three lanes in each direction.
- SR 429 Typical Section
  - Twelve lane typical section consisting of four C-D lanes in each direction and two travel lanes in each direction.
- I-4 Typical Section
  - Twelve lane typical section consisting of four general use lanes and two managed lanes in each direction. This typical section is consistent with proposed improvements identified by the I-4 BtU project. The I-4 BtU project will improve I-4 to address safety, mobility, and connectivity by extending improvements made during the I-4 Ultimate project further to the west and east including the area encompassing the I-4 and SR 429 interchange.
- Poinciana Parkway (SR 538) at CR 532 Interchange
  - Partial diamond interchange providing access to/from the north. Access to the south is not provided as a full interchange at US 17/92 is provided less than one-mile from CR 532.
- Poinciana Parkway (SR 538)/I-4/SR 429 Interchange
  - Alternative 1: Provides system-to-system connections with the Poinciana Parkway (SR 538) southbound lanes located south of the FGT and Gulfstream facilities and the northbound lanes located north of the FGT and Gulfstream facilities.

- Alternative 2: Similar to Alternative 1 except both directions of the Poinciana Parkway (SR 538) mainline are located south of the FGT and Gulfstream facilities.
- SR 429 at Sinclair Road Interchange
  - Modifications to existing diamond interchange.

Additional information related to the Build Alternatives is provided in the following sections.



Figure 4-1A: Alternative 1 (1 of 2)

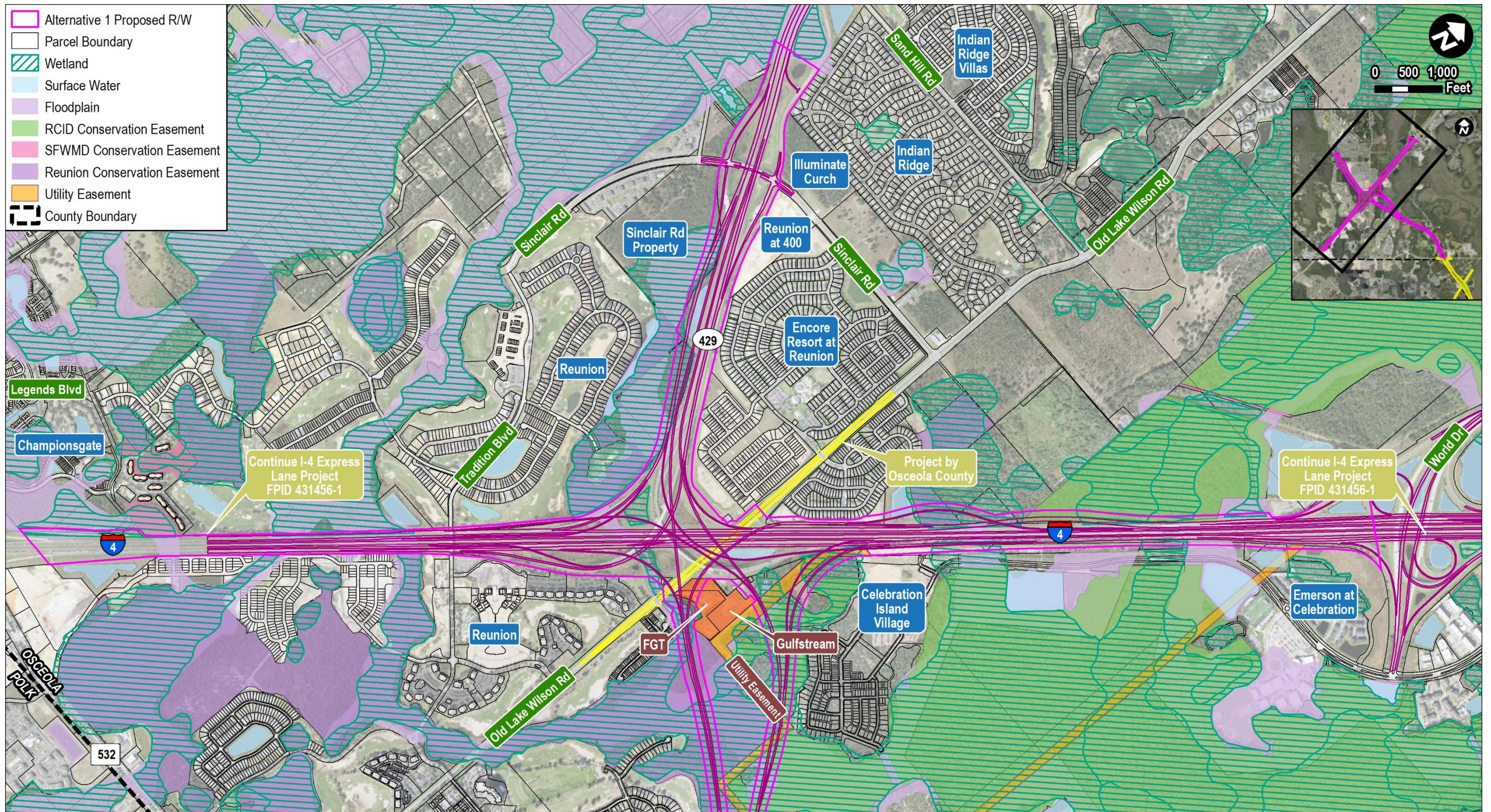




Figure 4-1B: Alternative 1 (2 of 2)

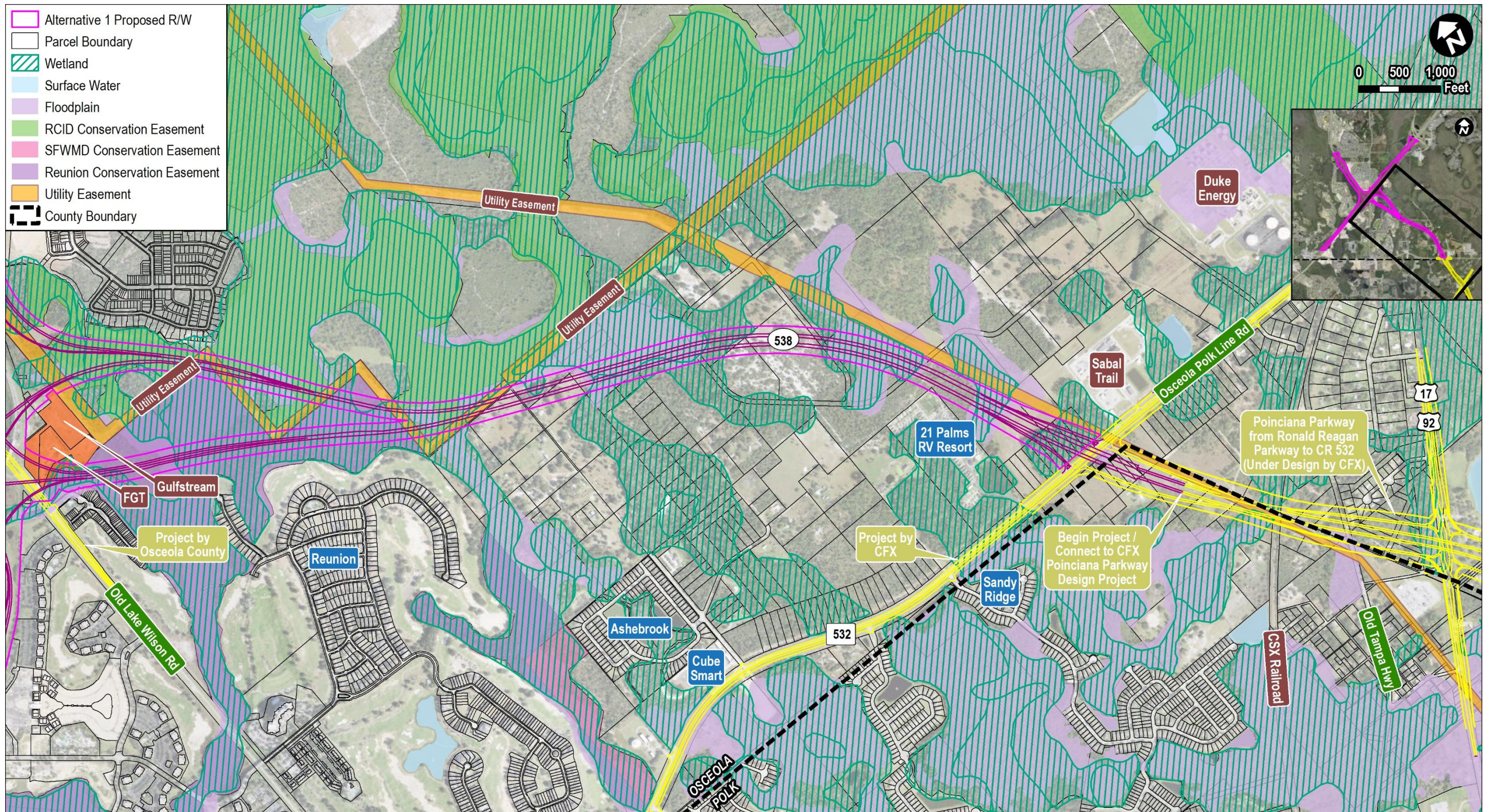




Figure 4-2A: Alternative 2 (1 of 2)

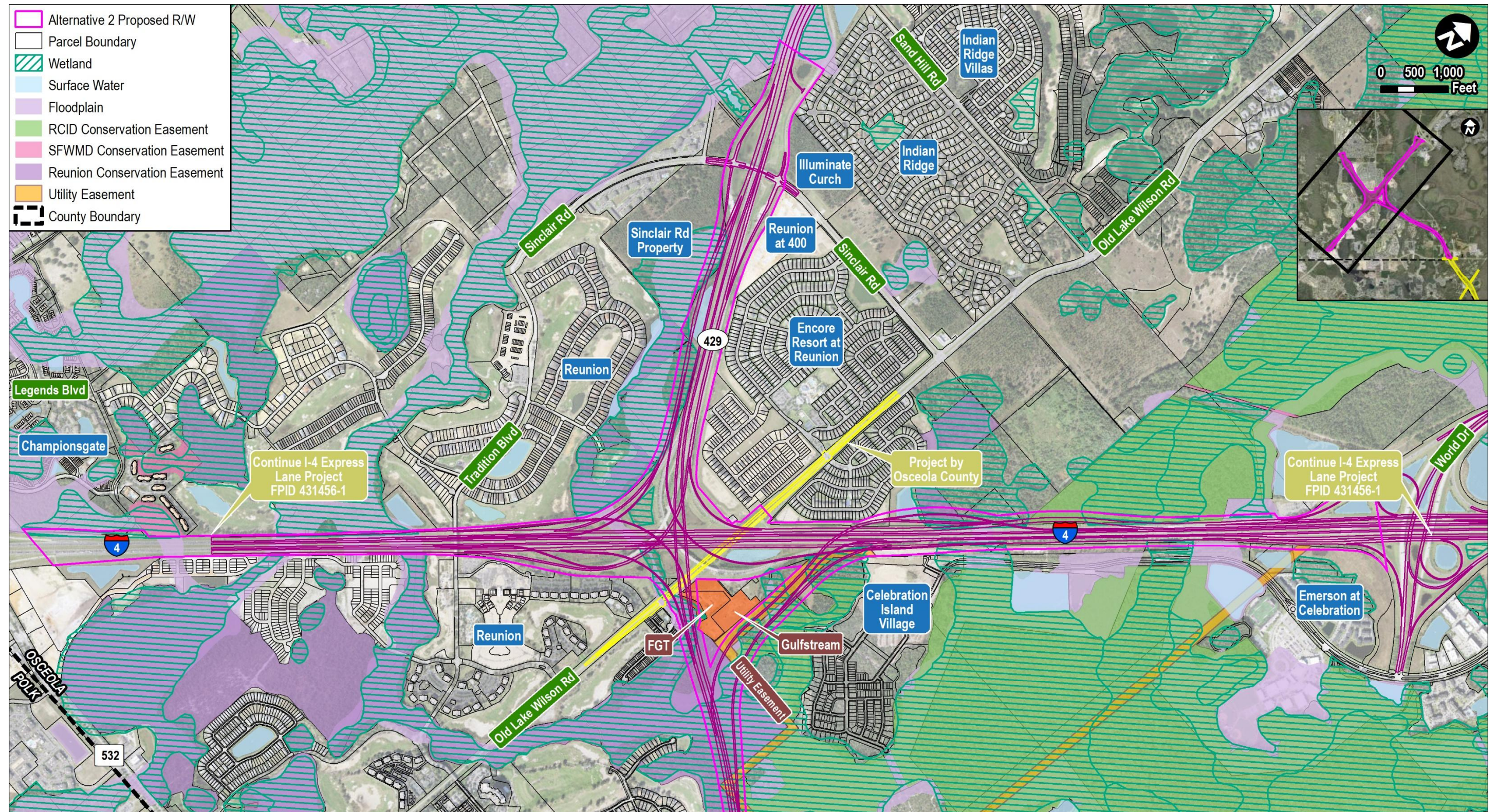
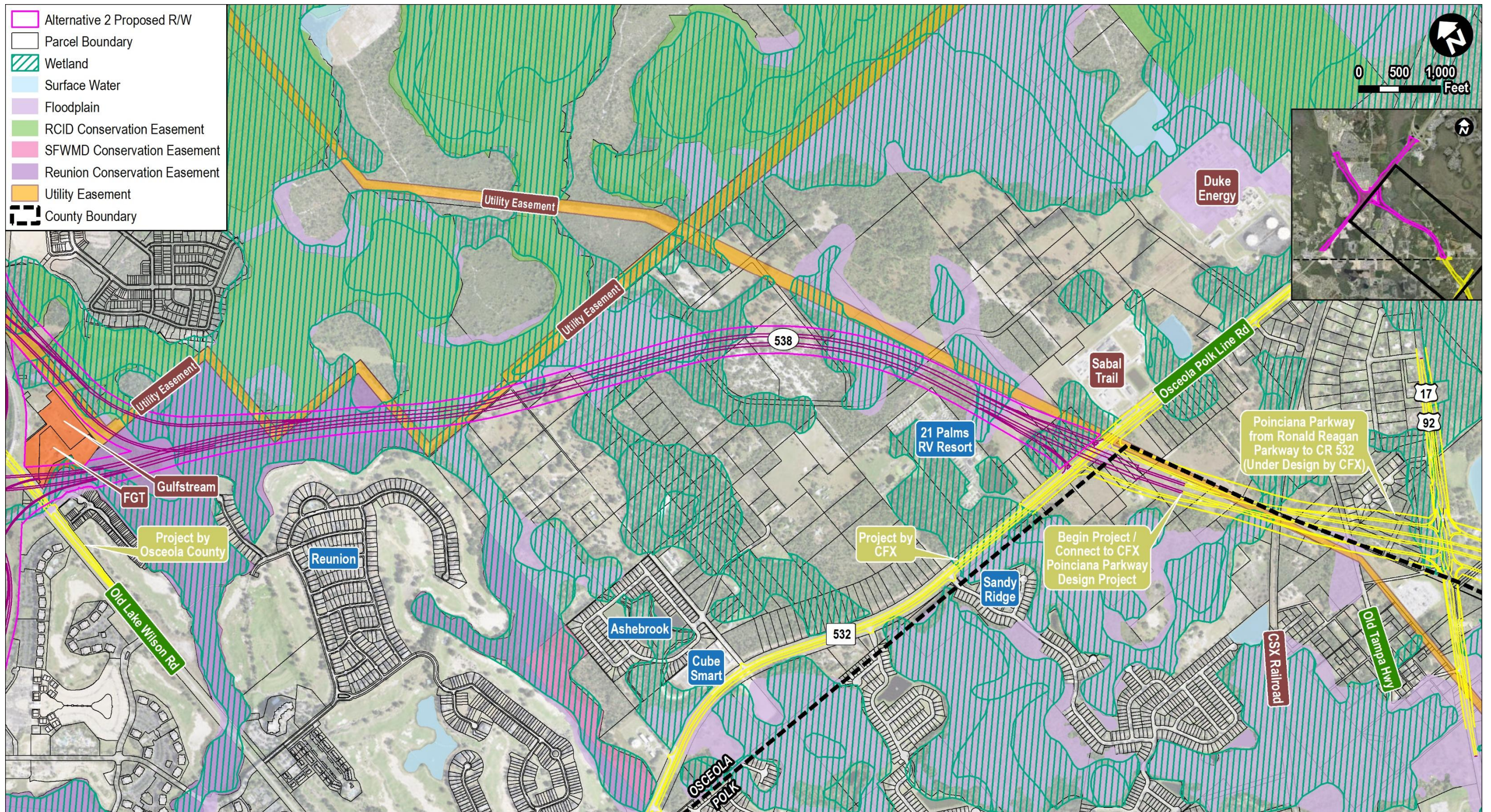




Figure 4-2B: Alternative 2 (2 of 2)

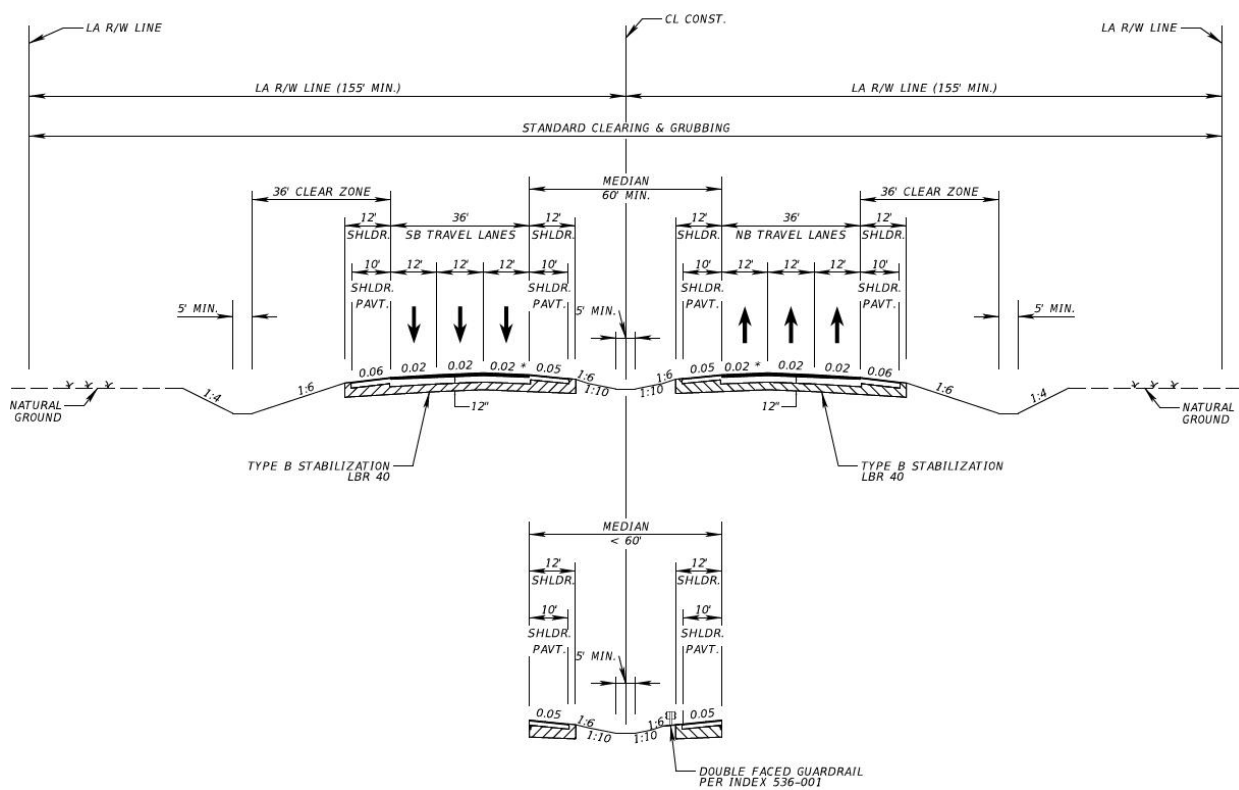




### 4.5.1 Poinciana Parkway (SR 538) Typical Section

One Build Alternative for the Poinciana Parkway (SR 538) mainline was considered. The proposed typical section is shown in Figure 4-3 and includes six 12-foot wide travel lanes (three in each direction) separated by a 50-foot wide median. The proposed limited access ROW width is 310 feet.

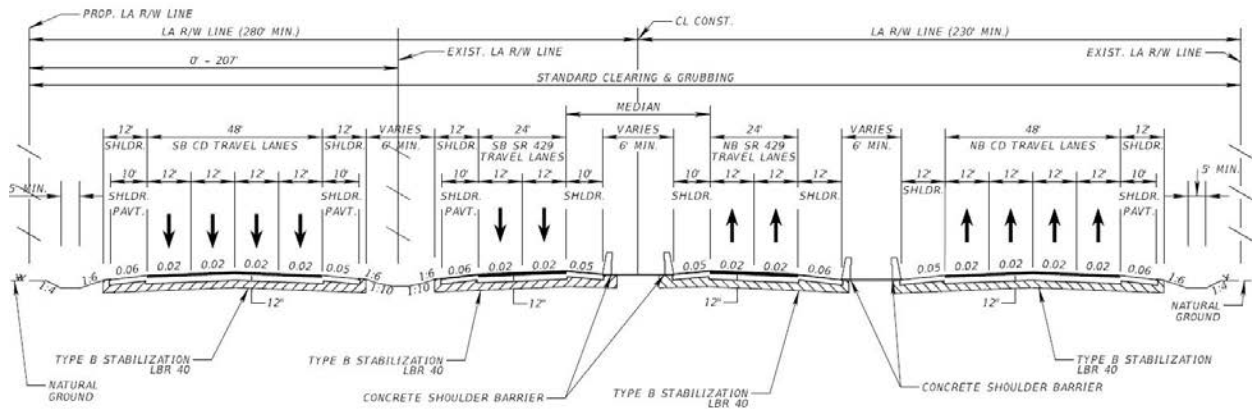
Figure 4-3: Poinciana Parkway (SR 538) Proposed Six-Lane Typical Section



### 4.5.2 SR 429 Typical Section

One Build Alternative for SR 429 was considered. The proposed typical section is shown in Figure 4-4 and includes twelve 12-foot wide lanes (six lanes in each direction consisting of four C-D lanes and two travel lanes). The existing limited access ROW varies from 303 to 510 feet. Segments of SR 429 will need up to 207 feet of additional ROW to accommodate the proposed typical section.

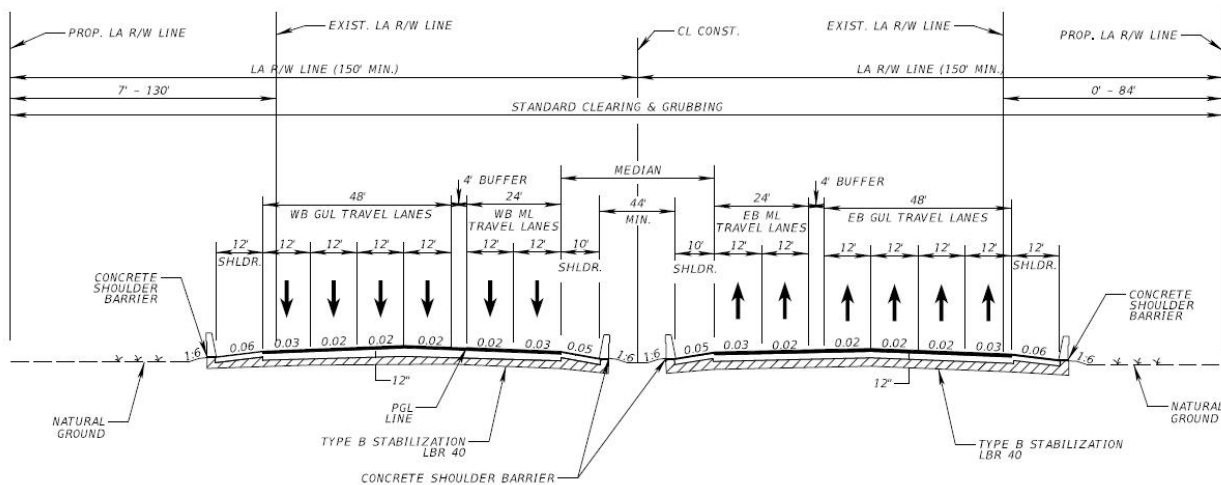
Figure 4-4: SR 429 Proposed Typical Section



4.5.3 I-4 Typical Section

One Build Alternative for the I-4 mainline was considered (Figure 4-5). The typical section includes twelve lanes (six lanes in each direction consisting of four 12-foot wide general use lanes and two 12-foot wide managed lanes). The proposed typical section is generally consistent with the I-4 BtU project except for some differences in order to accommodate the proposed bridge piers for the Poinciana Parkway (SR 538)/I-4/SR 429 interchange. These include buffer separation between the general use lanes and managed lanes instead of barrier wall and the inclusion of a barrier wall separating the inside shoulder from the 44-foot wide rail envelop. The proposed typical section requires 300 feet of ROW. Along segments of I-4, an additional 7 to 130 feet of ROW would be needed along the south side and 0 to 84 feet would be needed along the north side.

Figure 4-5: I-4 Proposed Typical Section



#### 4.5.4 Poinciana Parkway (SR 538) at CR 532 Interchange

FDOT's Capacity Analysis at Junctions (CAP-X) tool was used to screen options for the Poinciana Parkway (SR 538) interchange at CR 532. Multiple interchange configurations were considered as listed in Table 4-1 with the diamond interchange configuration selected as the preferred alternative due to its ability to accommodate travel demands, volume to capacity (V/C) ratio, minimal impacts, ease of construction, and anticipated cost. Other configurations, such as the partial cloverleaf, would operate with a lower V/C ratio; however, the diamond interchange can meet the operational needs with a smaller footprint and cost.

Table 4-1: CAP-X Analysis Summary – Poinciana Parkway (SR 538) at CR 532

Interchange Configuration	V/C Ratio		Comments
	AM	PM	
Diamond	0.46	0.71	Partial diamond interchange.
Displaced Left Turn Interchange	0.48	0.64	Displaced movement in eastbound direction only. Additional signal needed.
Single Point	0.52	0.71	Need additional eastbound left turn lane
Partial Cloverleaf B	0.48	0.54	No loop ramp needed for northbound left.
Partial Cloverleaf A	0.45	0.69	No loop ramp needed for westbound left.
Diverging Diamond Interchange	0.46	0.58	Needs additional through lanes.

Each ramp terminal was further evaluated to determine the appropriate intersection control. Table 4-2 summarizes the CAP-X results for the northbound on-ramp terminal with a continuous green T ranked one and a traffic signal ranked two.

Table 4-2: CAP-X Analysis – Poinciana Parkway (SR 538) at CR 532 Northbound Ramp

Alternative	AM V/C	PM V/C
Traffic Signal	0.64	0.65
Continuous Green T	0.50	0.36
1NS X 2EW Roundabout	0.91	0.94
2 X 2 Roundabout	0.91	0.94
All-Way Stop Control	2.31	2.44
Two-Way Stop Control E-W	0.91	0.63



Table 4-3 summarizes the CAP-X results for the southbound off-ramp terminal, with a traffic signal ranked one.

Table 4-3: CAP-X Analysis – Poinciana Parkway (SR 538) at CR 532 Southbound Ramp

Alternative	AM V/C	PM V/C
Traffic Signal	0.66	0.72
Continuous Green T	0.74	0.76
1NS X 2EW Roundabout	2.43	2.02
2 X 2 Roundabout	1.48	1.62
All-Way Stop Control	1.88	2.64
Two-Way Stop Control E-W	42.72	67.21

After factoring both AM and PM traffic results, a traffic signal is the preferred intersection control for the diamond interchange at CR 532.

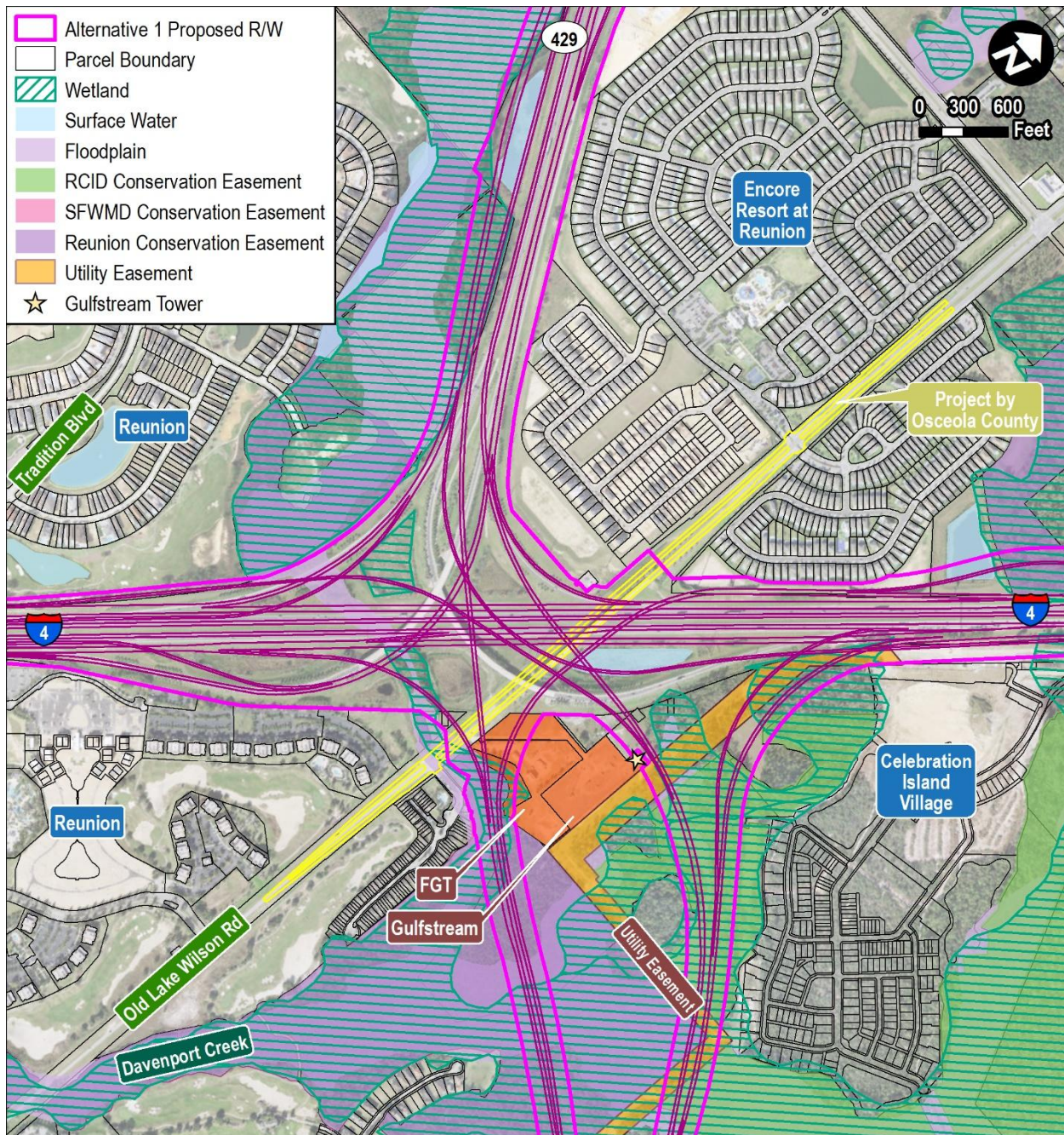
#### 4.5.5 Poinciana Parkway (SR 538)/I-4/SR 429 Interchange

Alternatives for the interchange at Poinciana Parkway (SR 538)/I-4/SR 429 were developed through an iterative process that considered the following elements:

- System-to-system connectivity
- Ability to accommodate traffic needs
- Ramp geometry to provide minimum 50 mph design speed
- Ramp spacing and configuration to minimize weaving issues
- Impacts to communities
- Impacts to conservation areas
- Impacts to utilities owned by FGT and Gulfstream
- Ability to construct while accommodating existing traffic
- Construction cost estimates
- ROW requirements

Two build alternatives were identified for consideration. Alternative 1 has a bifurcated mainline with the Poinciana Parkway (SR 538) southbound travel lanes located south of the FGT and Gulfstream facilities and the northbound travel lanes located north of the FGT and Gulfstream facilities (Figure 4-6). The southbound mainline and a southbound ramp bridge over the FGT site, although not directly impacting the FGT facility.

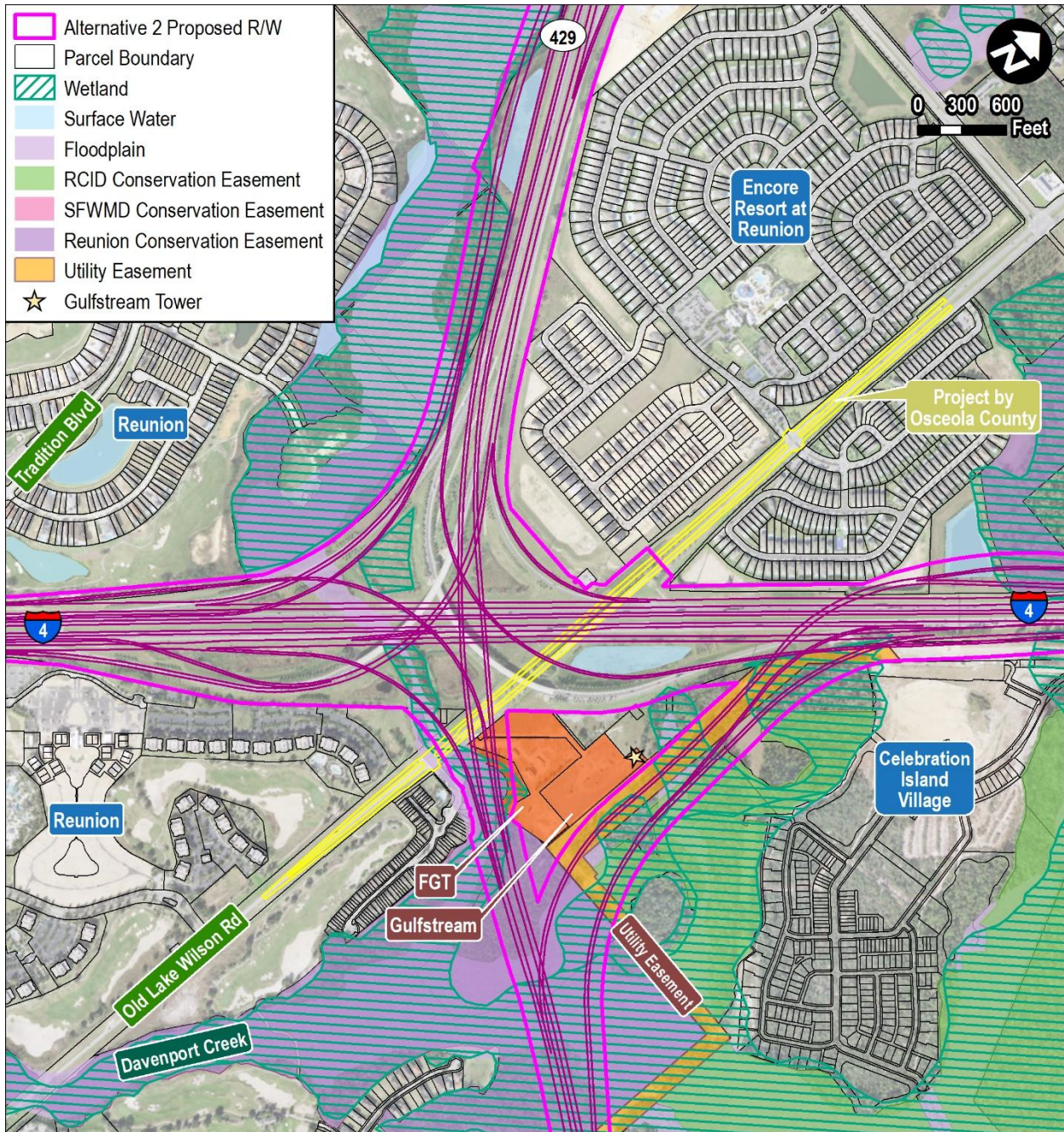
Figure 4-6: Alternative 1 through the Poinciana Parkway (SR 538)/I-4/SR 429 Interchange



Alternative 2 is similar to Alternative 1; however, both directions of the Poinciana Parkway (SR 538) mainline are located south of the FGT and Gulfstream facilities (Figure 4-7). Similar to Alternative 1, the northbound and southbound mainline lanes bridge over the FGT site, although further away from the existing buildings on the FGT site than in Alternative 1.



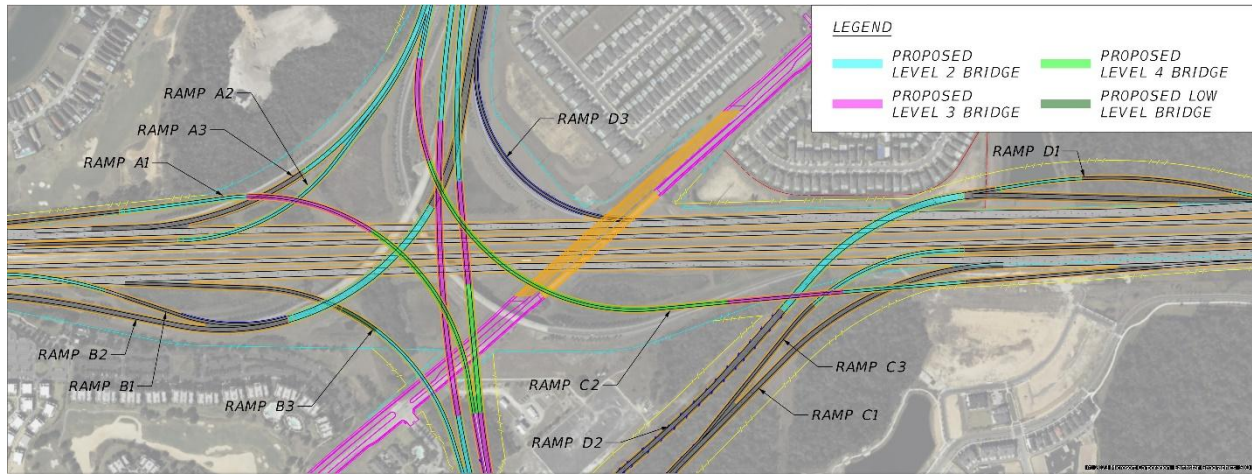
Figure 4-7: Alternative 2 through the Poinciana Parkway (SR 538)/I-4/SR 429 Interchange





Proposed system-to-system ramp designations, applicable to both Build Alternatives is provided in Figure 4-8.

Figure 4-8: Proposed System-to-System Ramp Designations



#### 4.5.6 SR 429 at Sinclair Road Interchange

FDOT’s CAP-X tool was used to screen options for the SR 429 interchange at Sinclair Road. Multiple interchange configurations were considered as listed in Table 4-4 with the diamond interchange configuration selected as the preferred alternative based on its ability to accommodate travel demands, minimal impacts, ease of construction, and anticipated cost. All other interchange configurations would operate at a lower V/C ratio; however, they would require extensive cost and reconstruction of the existing interchange. Modifying the existing diamond interchange would meet the operational needs for the Design Year.

Table 4-4: CAP-X Analysis Summary – SR 429 at Sinclair Road

Interchange Configuration	V/C Ratio		Comments
	AM	PM	
Diamond	0.65	0.80	Existing geometry provides adequate V/C.
Diverging Diamond Interchange	0.31	0.47	Requires widening bridge. Geometric challenges.
Single Point	0.60	0.73	Requires widening bridge. Geometric challenges.
Displaced Left Turn Interchange	0.52	0.54	Requires widening bridge.
Partial Cloverleaf B	0.50	0.38	Utility and ROW impacts.
Partial Cloverleaf A	0.30	0.46	Utility and ROW impacts.

The ramp terminals were further evaluated to determine the appropriate intersection control. Table 4-5 summarizes the CAP-X results. The traffic signal is the preferred intersection control options.

Table 4-5: CAP-X Analysis Summary – SR 429 at Sinclair Ramps

Alternative	AM V/C	PM V/C
Traffic Signal	0.75	0.76
2 X 2 Roundabout	0.58	1.23
1NS X 2EW Roundabout	0.69	1.51
Two-Way Stop Control E-W	23.38	16.26

#### 4.5.7 Proposed Structures

##### 4.5.7.1 Alternative 1

Alternative 1 proposes that northbound Poinciana Parkway (SR 538) be located north of the FGT/Gulfstream station, and southbound Poinciana Parkway (SR 538) be located south of the FGT/Gulfstream station. The Poinciana Parkway (SR 538) bridges that tie-in to SR 429 will carry two southbound lanes and two northbound lanes through the interchange. The Poinciana Parkway (SR 538) bridges over I-4 will utilize steel girders. As Poinciana Parkway (SR 538) moves south and away from the interchange, the bridges can transition from steel to prestressed concrete beams for the Davenport Creek crossing. The existing flyovers (Ramp B and C) are to be replaced by Ramps B2 and C2. Traffic can be maintained for both Ramp B and Ramp C movements during construction.

Ramps A1, A2, B1, B3, C2, C3 and D1 are proposed single lane ramps utilizing steel girders. Ramps C1, and D2 are proposed two-lane ramps. Ramp C1 will utilize prestressed concrete beams and Ramp D2 will utilize steel girders. Ramp B2 is a three-lane ramp utilizing steel girders. Ramp A3 is a proposed ramp with varying lane configurations utilizing prestressed concrete beams. See Figures 4-9 through 4-20 for the proposed typical sections for Alternative 1. All ramps are based on a 50 MPH design speed.

The structures proposed to be constructed throughout the corridor will meet minimum vertical clearance of 16.5 feet per FDM 260. Bridge lengths were established such that mechanically stabilized earth (MSE) retaining wall heights do not exceed 40 feet.

A single straddle bent will be utilized for each of the Ramp A2, B1, C3, and D1 bridge configurations. These bridges provide connections to the proposed I-4 BtU managed lanes. One integral pier cap is anticipated on Ramps B1 and C2. Two integral pier caps are anticipated on Ramp B2.

Figure 4-9: Typical Section for Ramp A1

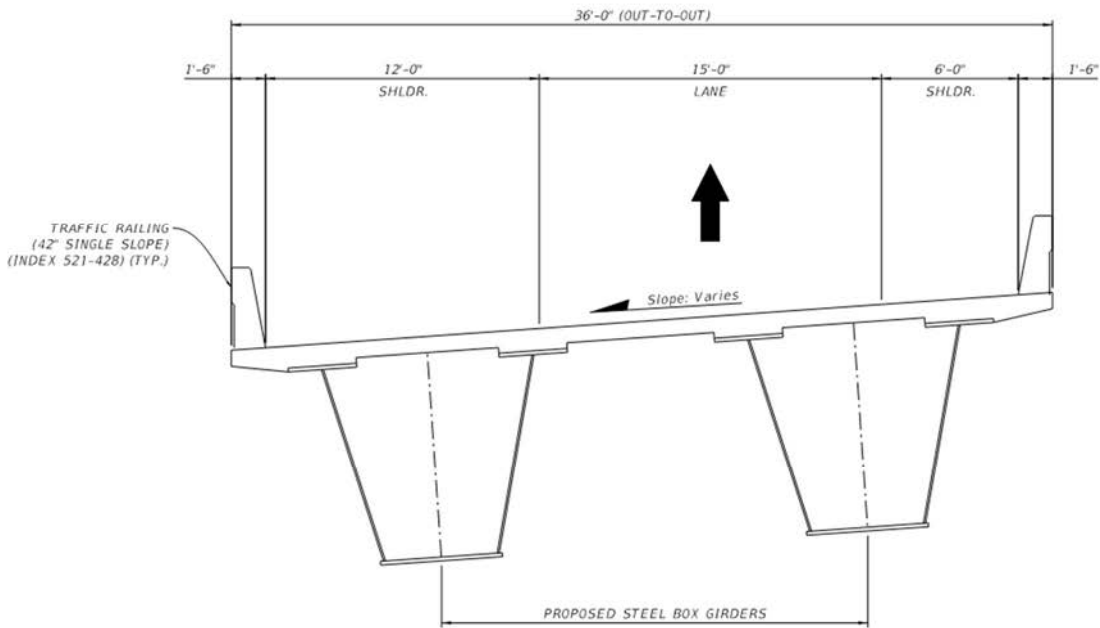


Figure 4-10: Typical Section for Ramp A2

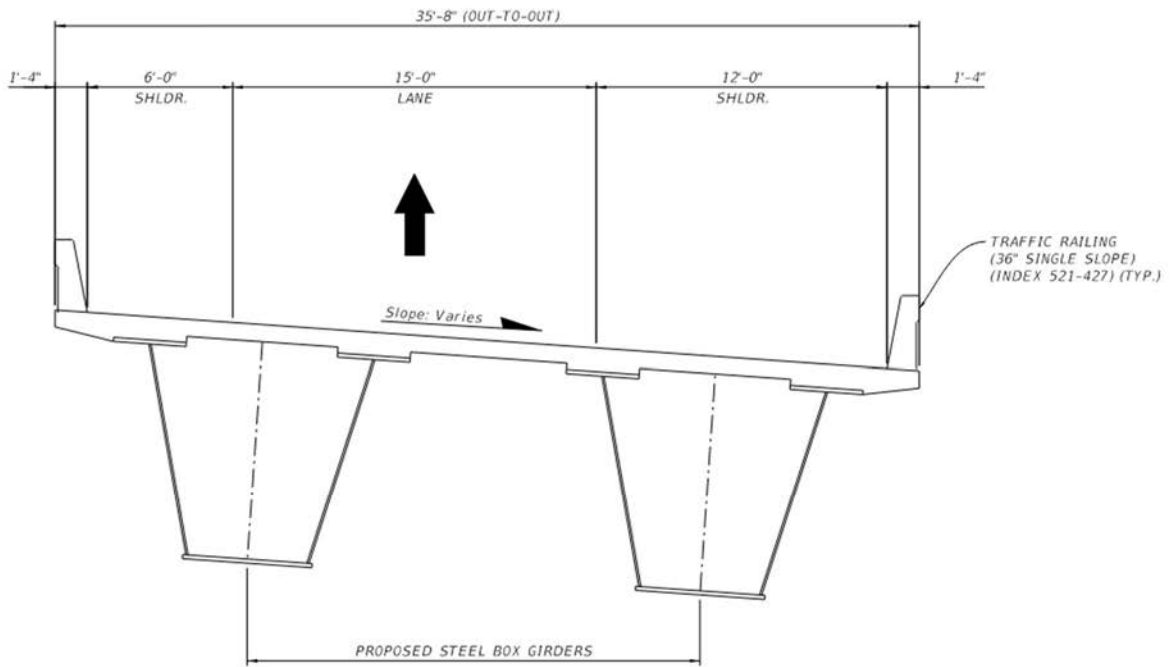




Figure 4-11: Typical Section for Ramp A3

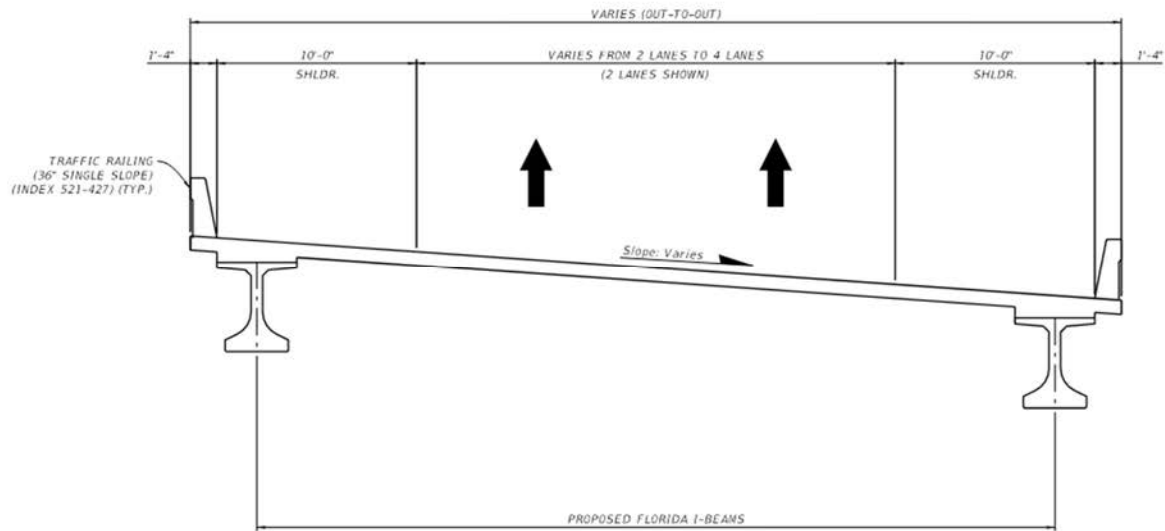


Figure 4-12: Typical Section for Ramp B1

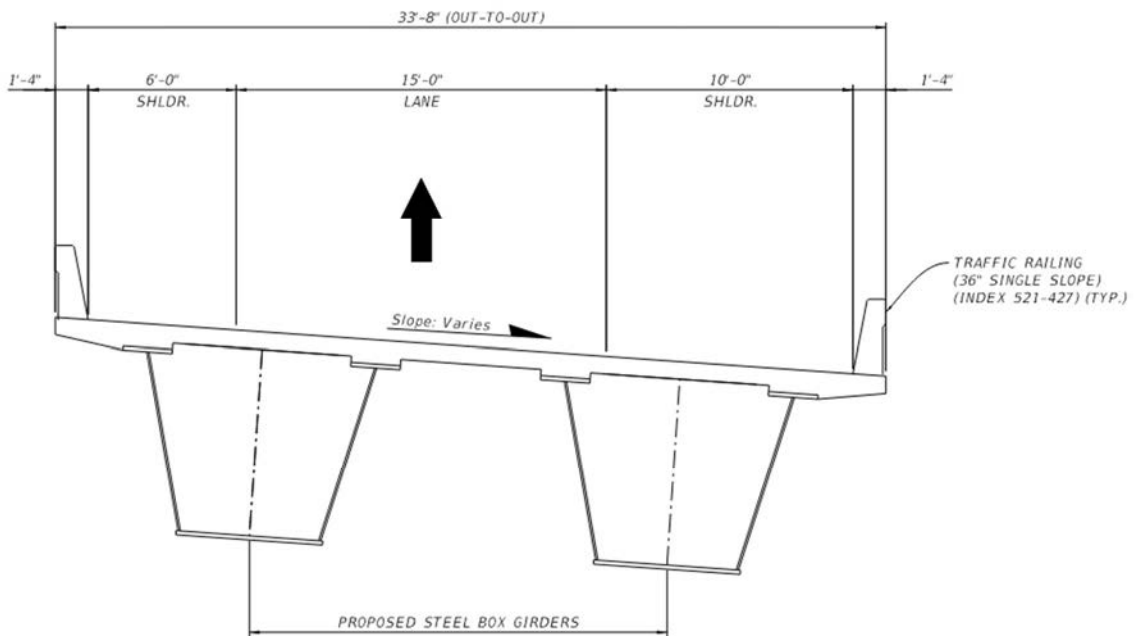


Figure 4-13: Typical Section for Ramp B2

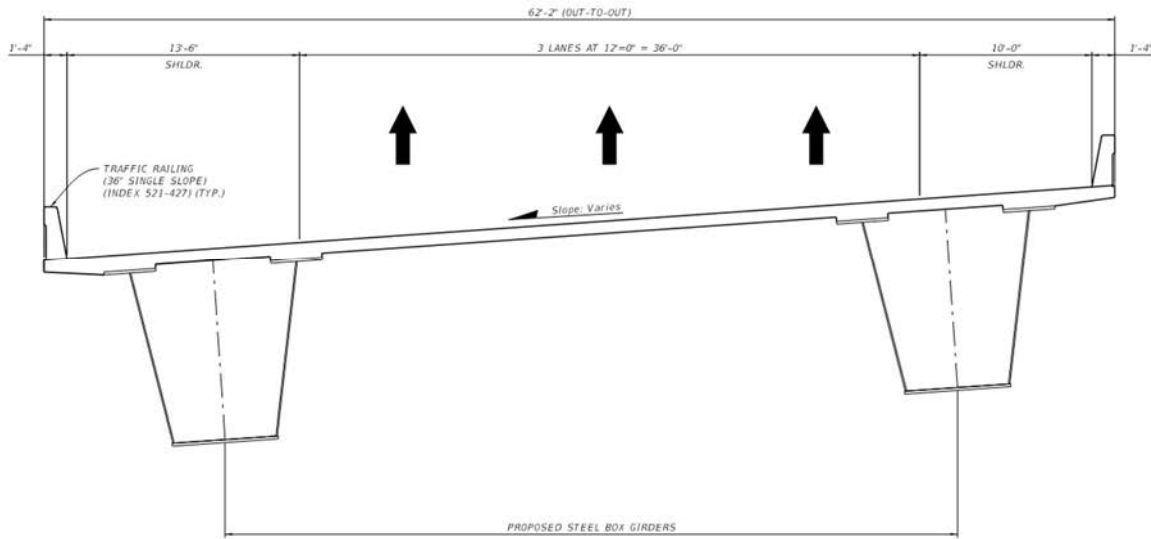


Figure 4-14: Typical Section for Ramp B3

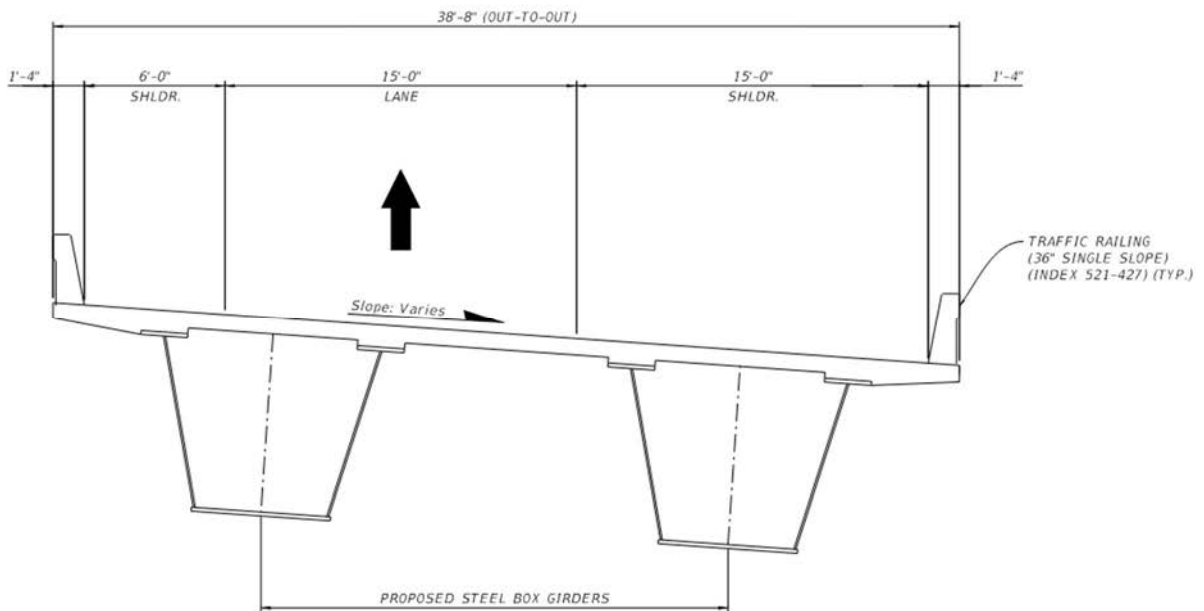


Figure 4-15: Typical Section for Ramp C1

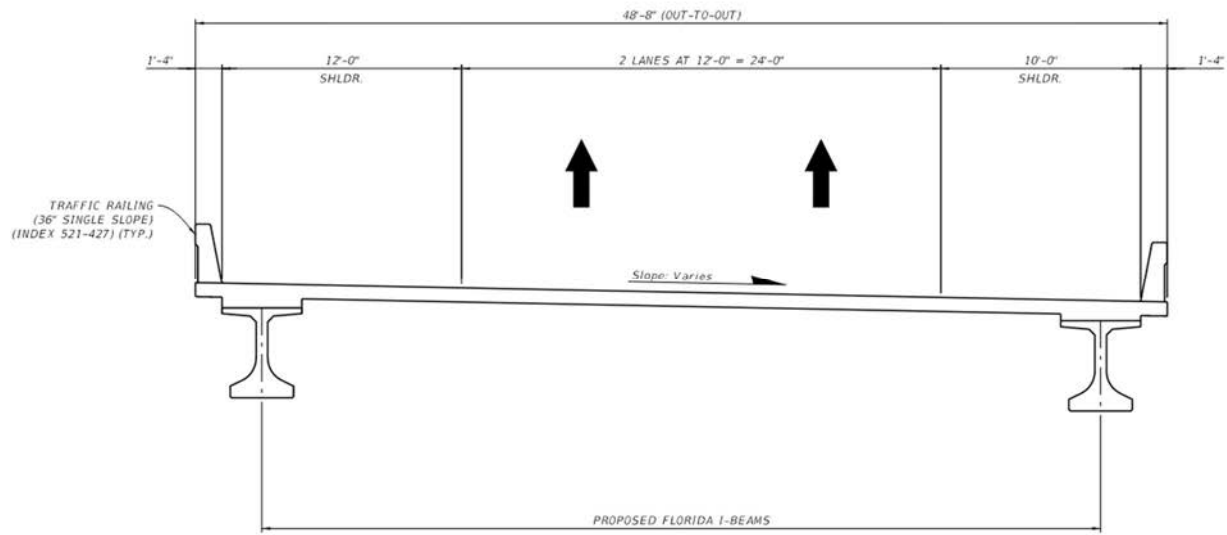


Figure 4-16: Typical Section for Ramp C2

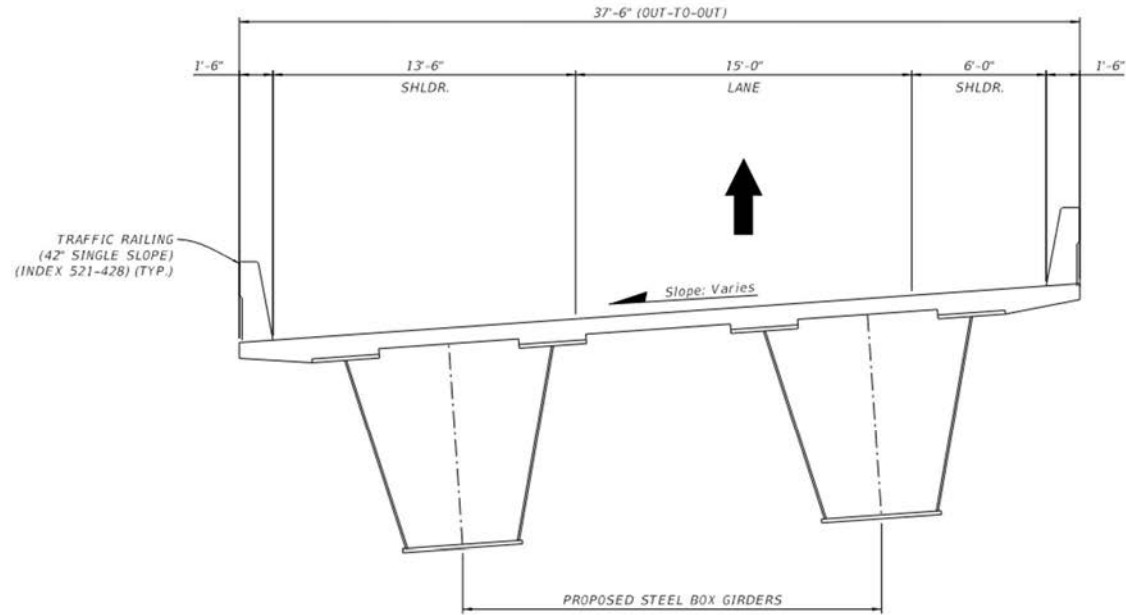


Figure 4-17: Typical Section for Ramp C3

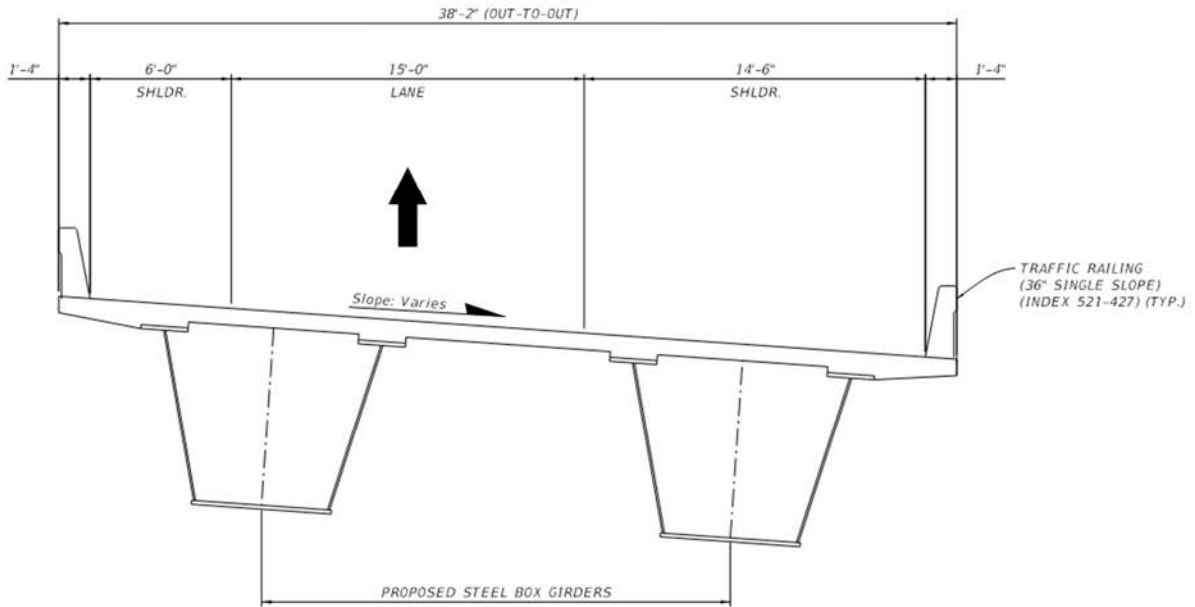


Figure 4-18: Typical Section for Ramp D1

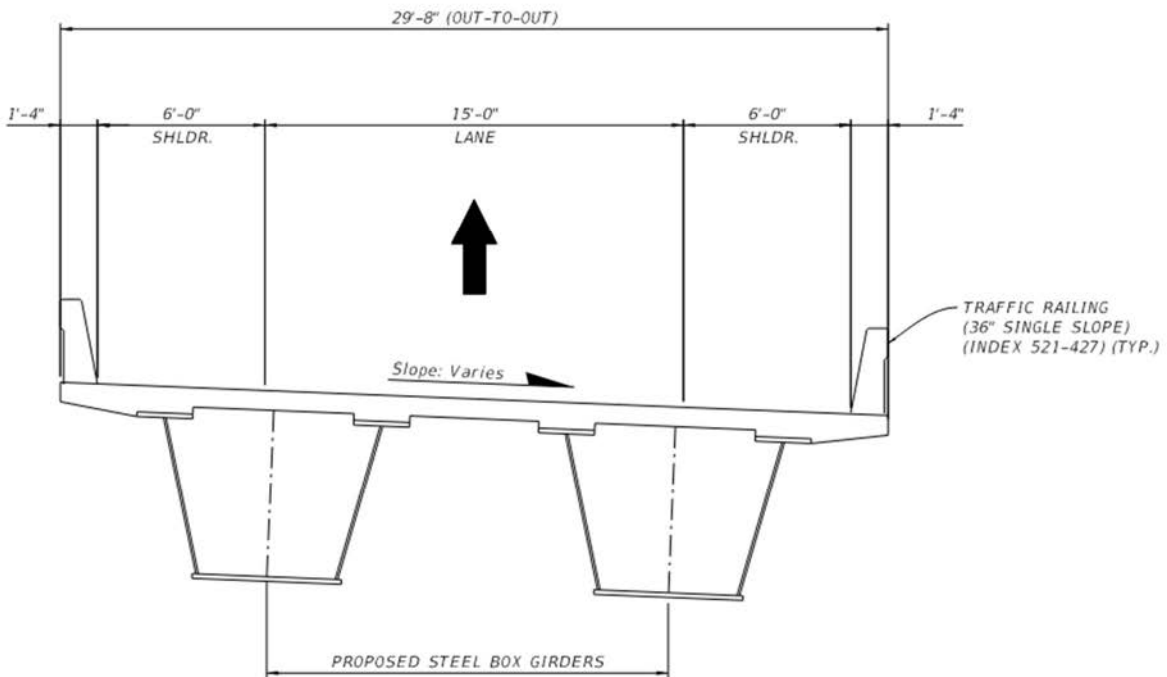


Figure 4-19: Typical Section for Ramp D2

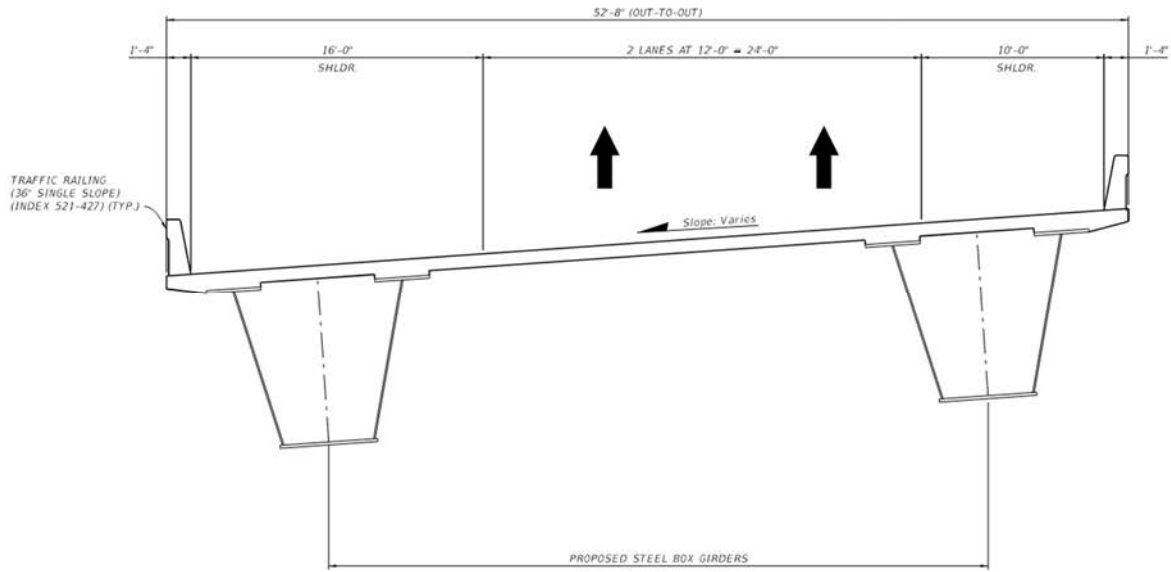
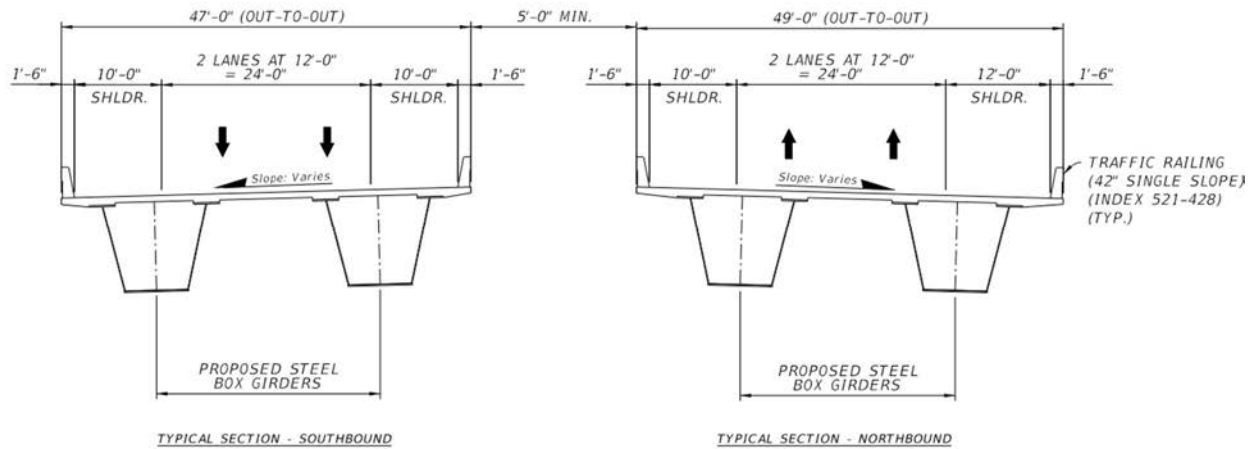


Figure 4-20: Typical Section for Northbound and Southbound Poinciana Parkway (SR 538)



#### 4.5.7.2 Alternative 2

Alternative 2 proposes that both northbound and southbound Poinciana Parkway (SR 538) are located south of the FGT/Gulfstream station. The Poinciana Parkway (SR 538) bridges that tie-in to SR 429 will carry two southbound lanes and two northbound lanes through the interchange. Poinciana Parkway (SR 538) over I-4 will utilize steel girders. As Poinciana Parkway (SR 538) moves south and away from the interchange, the bridges can transition from steel to prestressed concrete beams for the Davenport Creek crossing. The existing flyovers (Ramp B and C) are to be replaced by Ramps B2 and C2. Traffic can be maintained for both Ramp B and Ramp C movements during construction.

Ramps A1, A2, B1, B3, C2, C3 and D1 are proposed single lane ramps utilizing steel girders. Ramp C1 is a proposed two-lane ramp and will utilize prestressed concrete beams. Ramp D2 is a proposed ramp with varying lane configurations. As Ramp D2 moves south and away from I-4, the bridge can transition from steel to prestressed concrete beams. Ramp B2 is a three-lane ramp and will utilize steel girders. Ramp A3 is a proposed ramp with varying lane configurations utilizing prestressed concrete beams. See Figures 4-21 through 4-32 for proposed typical sections for Alternative 2. All ramps are based on a 50 MPH design speed.

The structures proposed to be constructed throughout the corridor will meet minimum vertical clearance of 16.5 feet per FDM 260. Bridge lengths were established such that MSE wall heights do not exceed 40 feet.

A single straddle bent will be utilized for each of the Ramp A2, B1, C3, and D1 bridge configurations. These bridges provide connections to the proposed I-4 BtU express lanes. One integral pier cap is anticipated on Ramp B1. Two integral pier caps are anticipated on Ramp B2.



Figure 4-21: Typical Section for Ramp A1

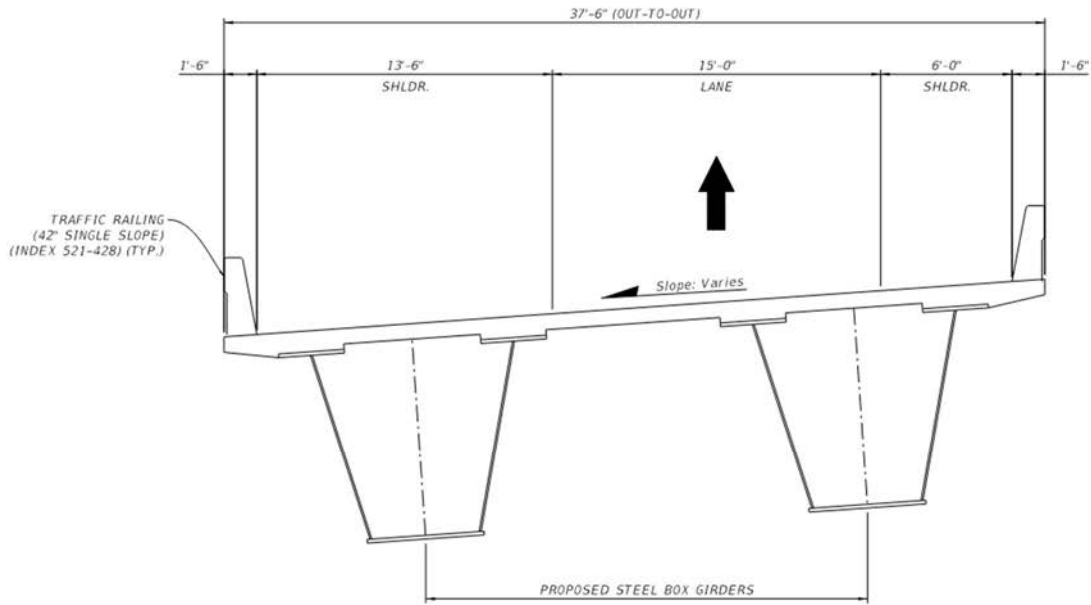


Figure 4-22: Typical Section for Ramp A2

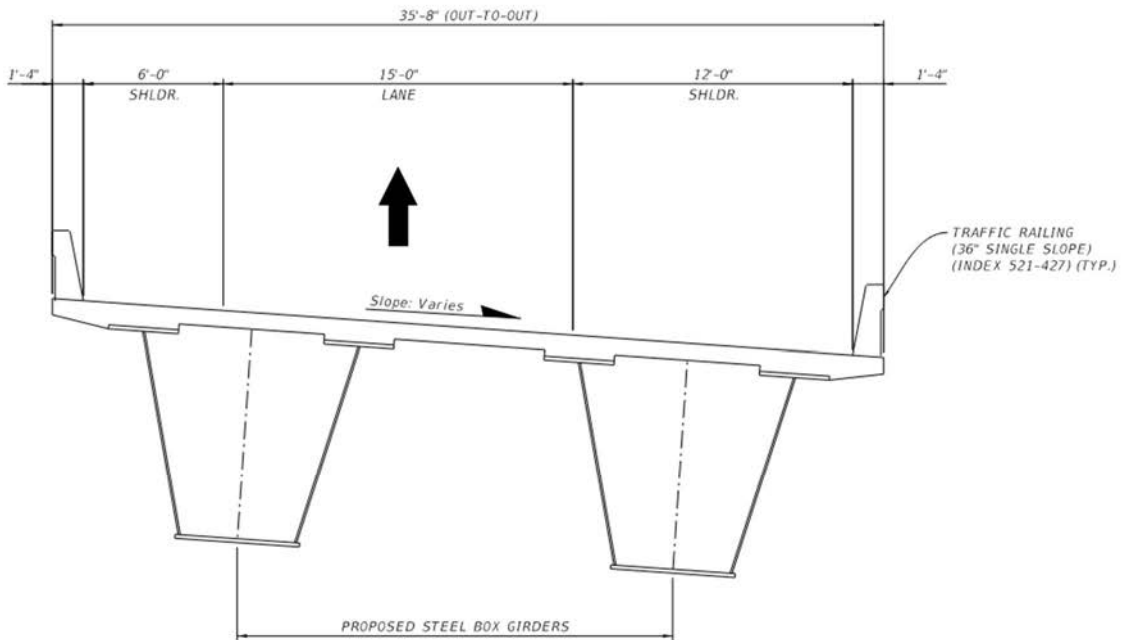


Figure 4-23: Typical Section for Ramp A3

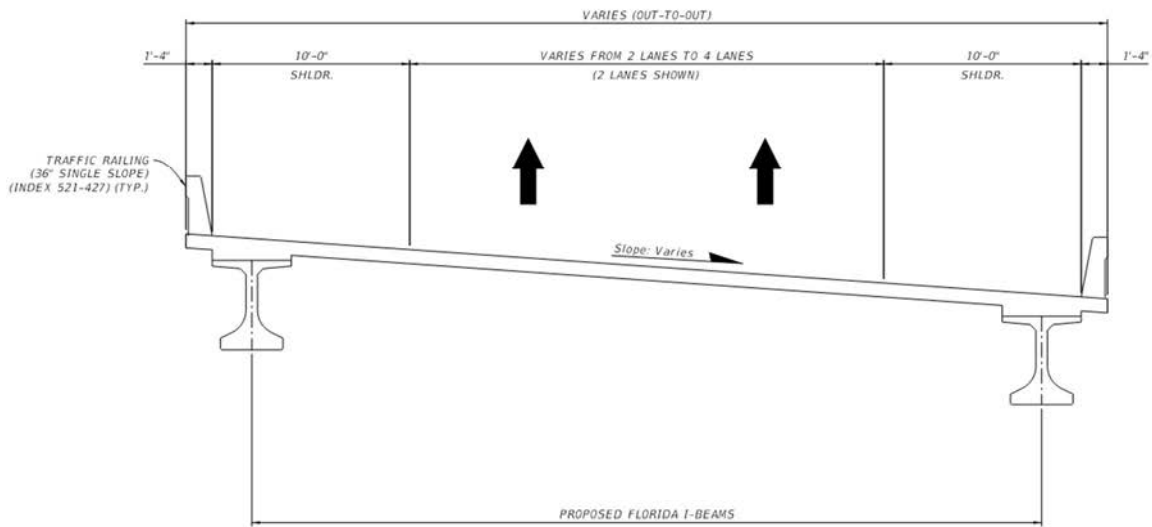


Figure 4-24: Typical Section for Ramp B1

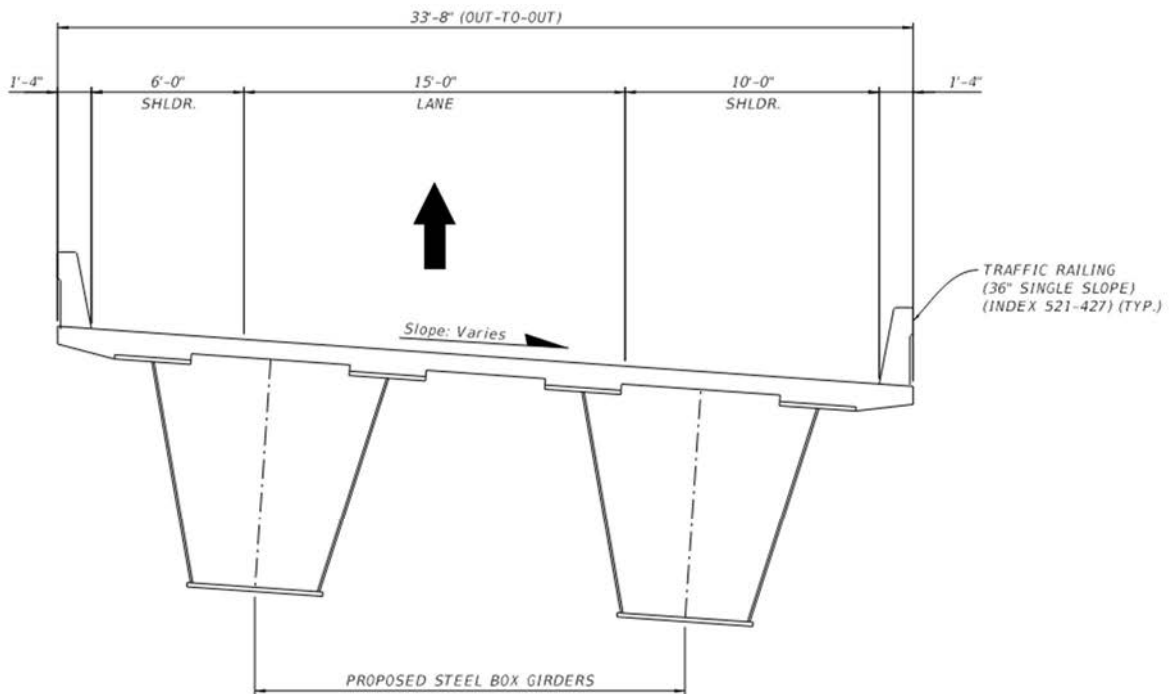


Figure 4-25: Typical Section for Ramp B2

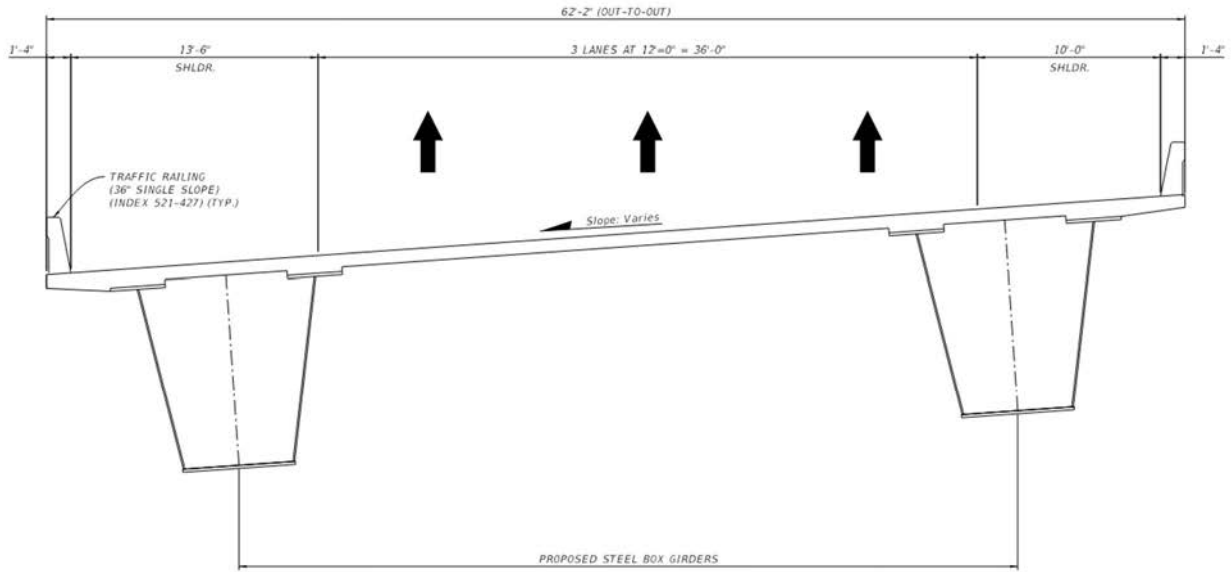


Figure 4-26: Typical Section for Ramp B3

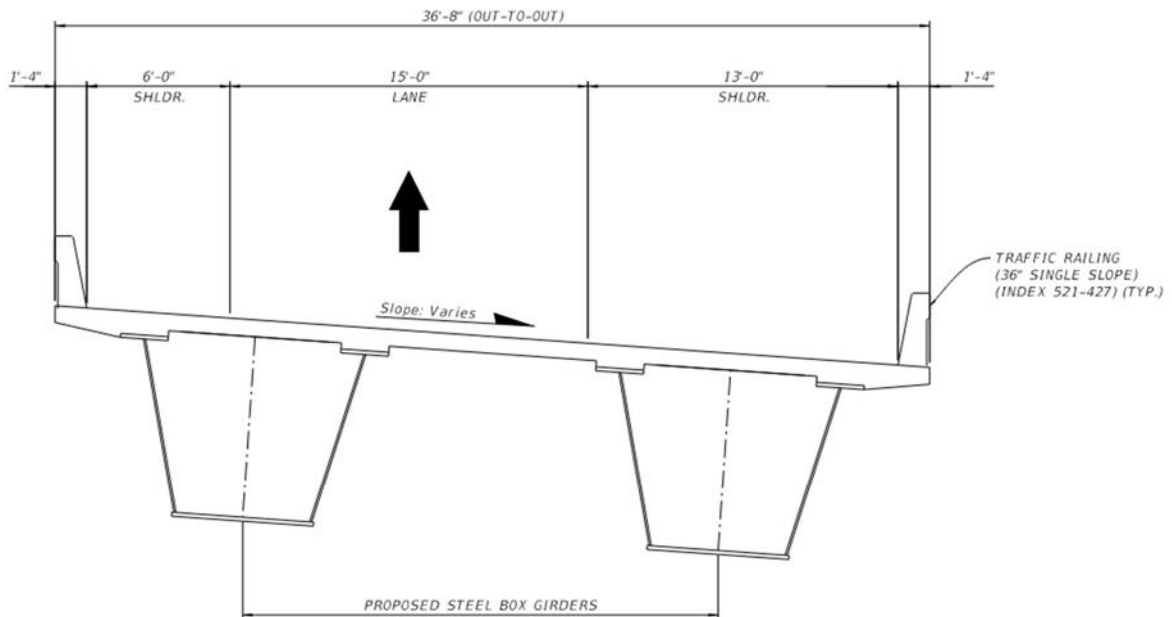


Figure 4-27: Typical Section for Ramp C1

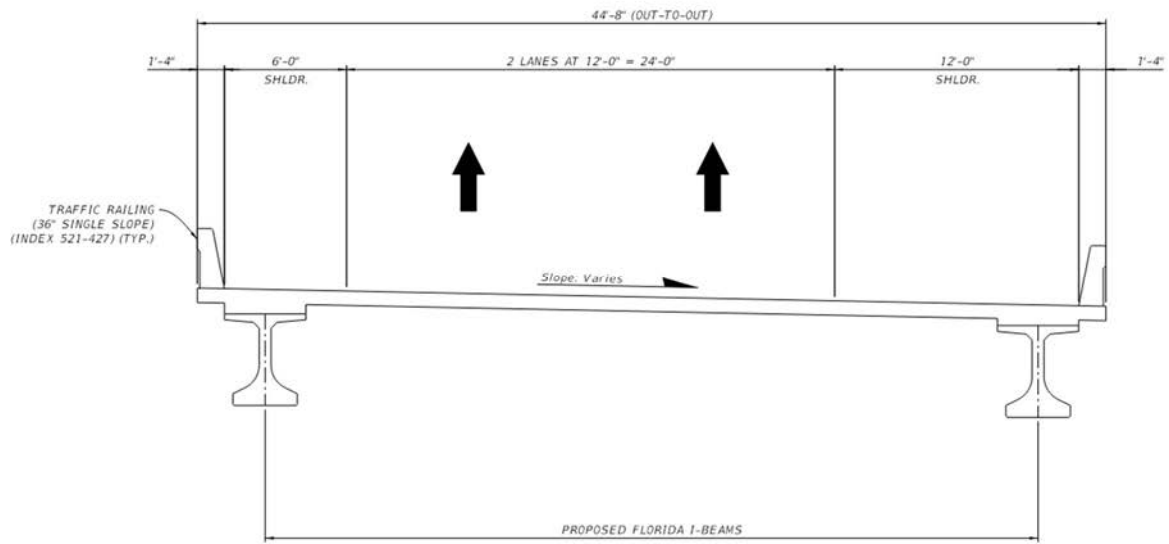


Figure 4-28: Typical Section for Ramp C2

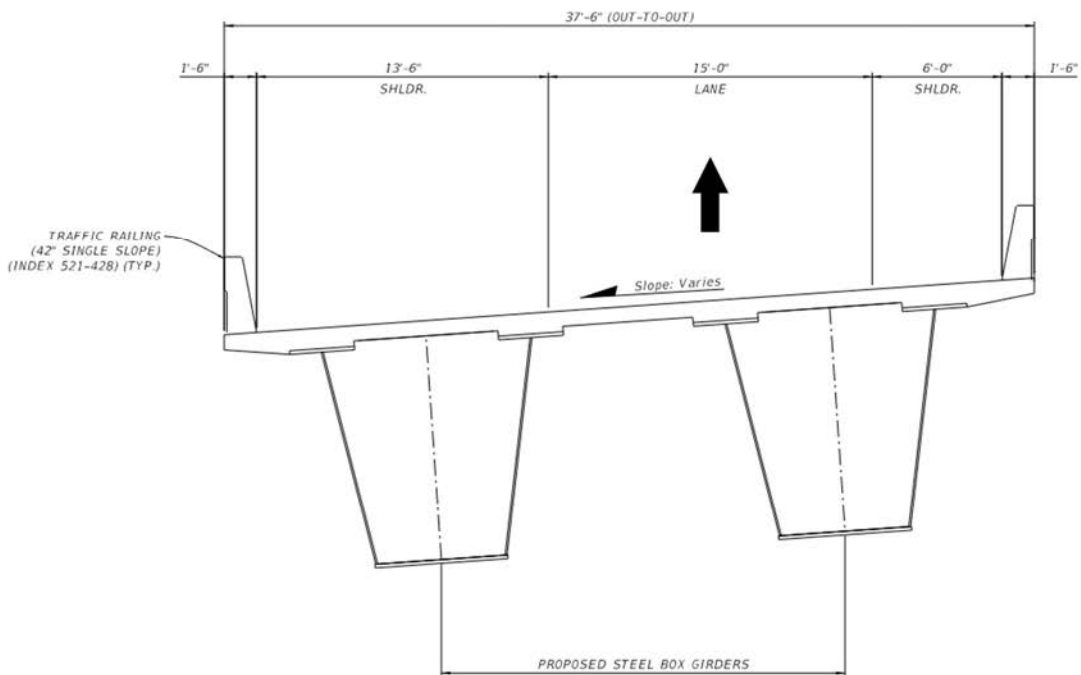


Figure 4-29: Typical Section for Ramp C3

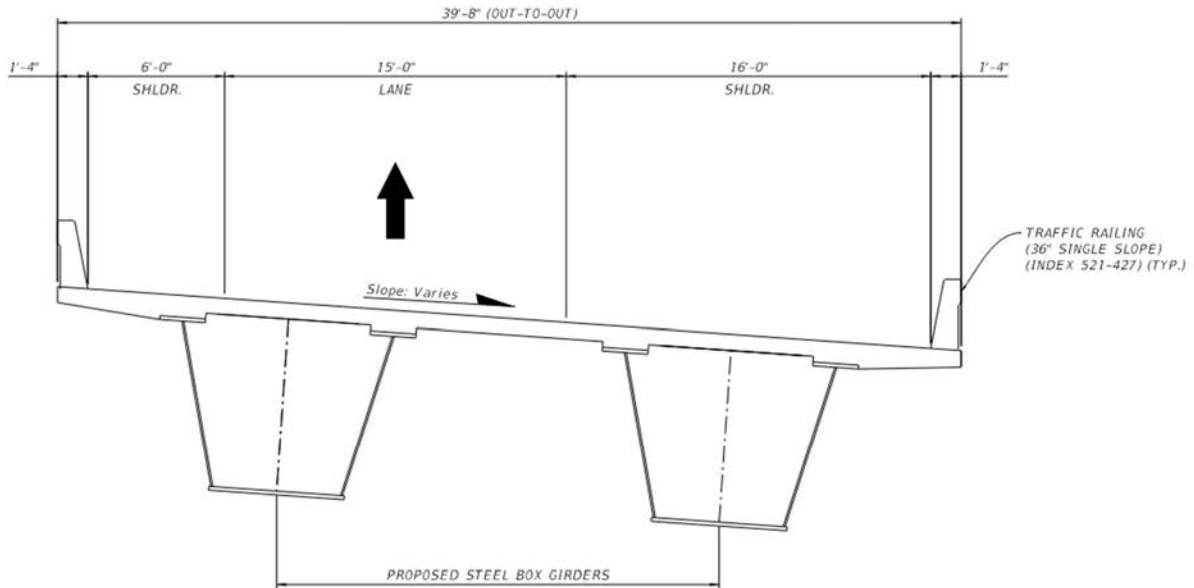


Figure 4-30: Typical Section for Ramp D1

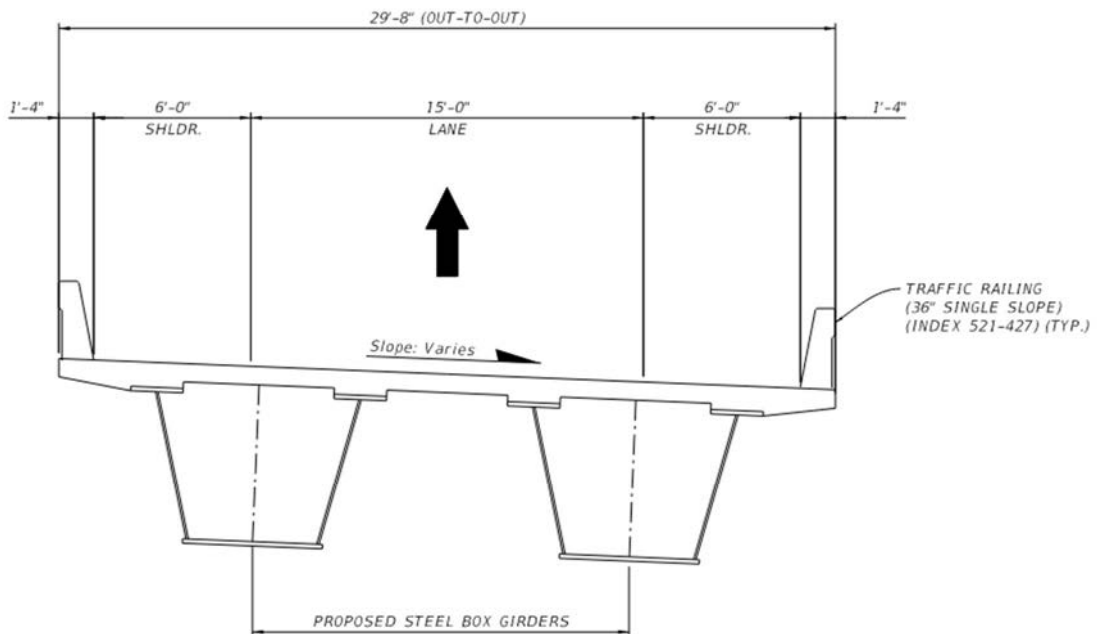


Figure 4-31: Typical Section for Ramp D2

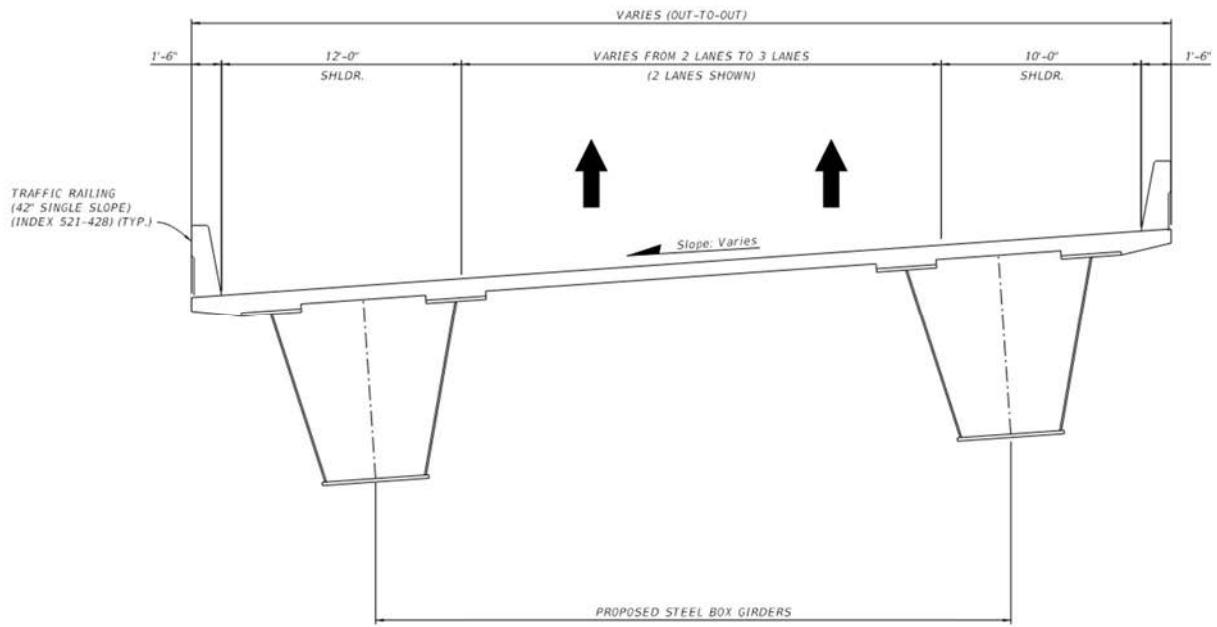
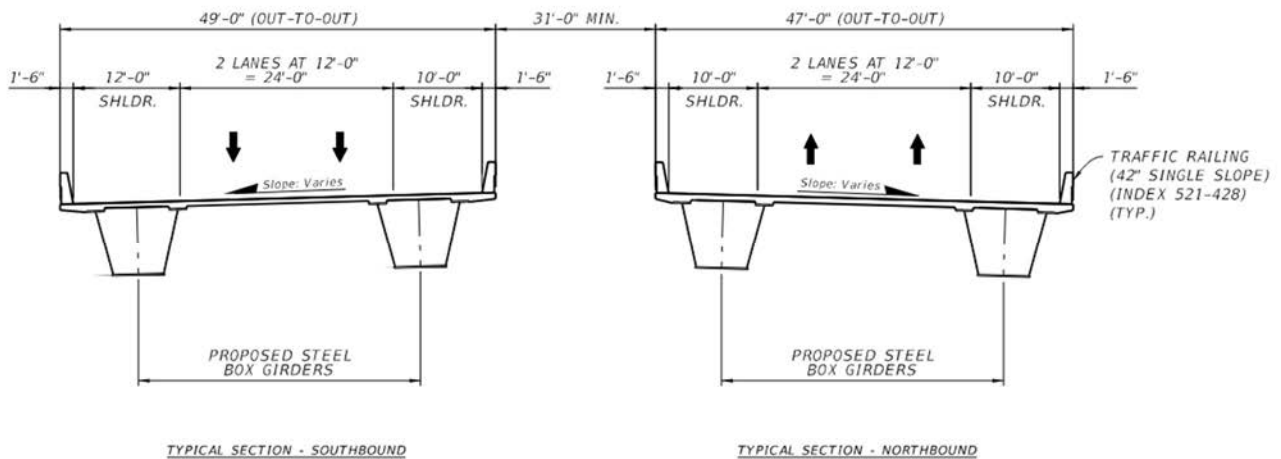


Figure 4-32: Typical Section for Northbound and Southbound Poinciana Parkway (SR 538)

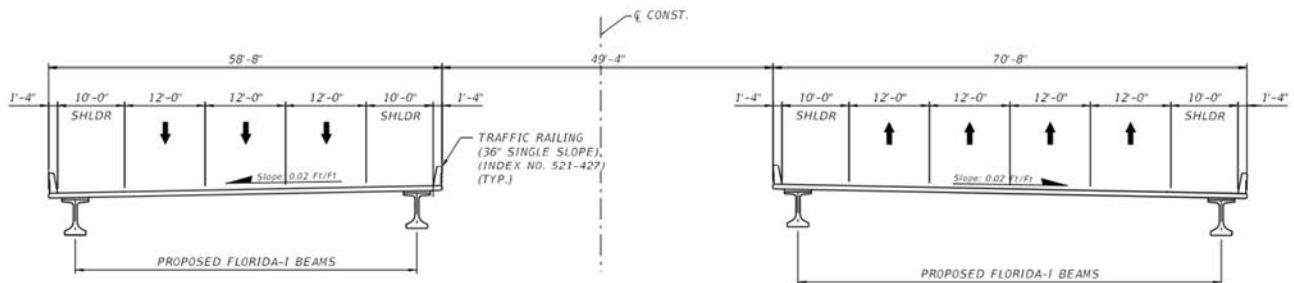




4.5.7.3 County Road 532

Two proposed parallel bridges will carry the extension of Poinciana Parkway (SR 538) over CR 532. These proposed single-span structures are the same for both interchange alternatives. The northbound bridge will carry four lanes and the southbound bridge will carry three lanes (see Figure 4-33). Both bridges will utilize prestressed concrete beams.

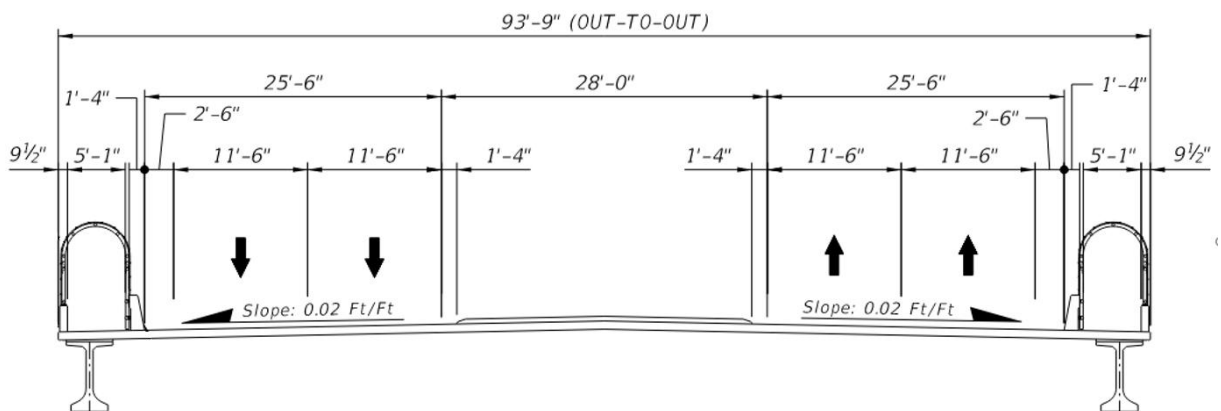
Figure 4-33: Typical Section for SR 429 over CR 532



4.5.7.4 Sinclair Road

The existing structure carrying Sinclair Road over SR 429 will not be replaced. The existing structure carries four 11.5-foot wide vehicular lanes (two lanes in each direction) with 2.5-foot wide exterior shoulders, two 5-foot wide sidewalks with fully enclosed bridge fencing, and a 28-foot wide median (including one-foot-four-inch interior shoulders). The total width of the existing structure is 93-feet-9-inches (see Figure 4-34).

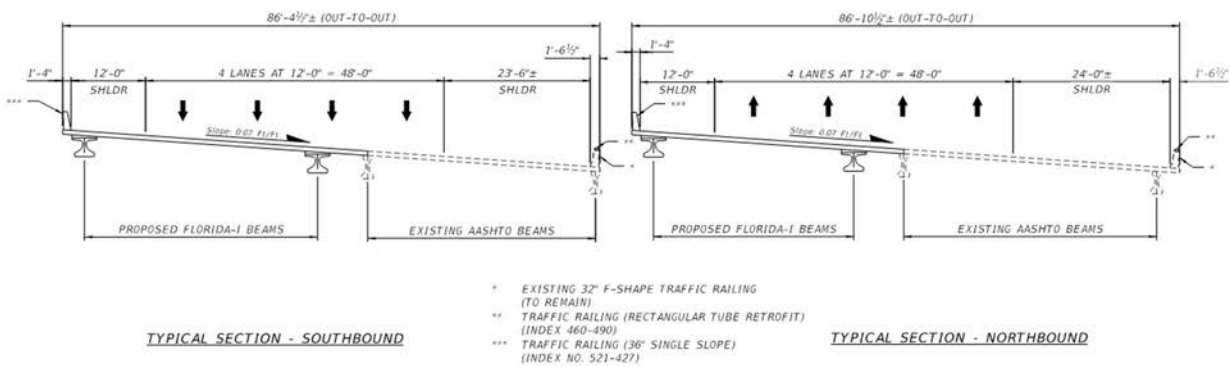
Figure 4-34: Typical Section for Sinclair Road



## 4.5.7.5 Sand Hill Road

The existing SR 429 bridges over Sand Hill Road will be widened from two-lanes to four-lanes. Both bridges will be widened to the west which will maintain the existing minimum vertical clearance. Additionally, widening to the west will increase constructability for the new MSE wall along the westside bridge approaches and maintain the bridge widening within the existing ROW. The widening will utilize prestressed concrete beams (see Figure 4-35).

Figure 4-35: Typical Section for SR 429 over Sand Hill Road



## 4.5.7.6 Tradition Boulevard

The proposed I-4 mainline configuration maintains the existing Tradition Boulevard bridge. For both alternatives, vertical clearance over I-4 is sufficient. At the north abutment, a new retaining wall will be required in front of the existing MSE wall to accommodate grading for the proposed I-4 widening. The south abutment is outside the clear zone but may require a new retaining wall to accommodate grading for the proposed I-4 widening. The existing center pier has the required protection as it is also within the clear zone.

#### 4.6 Comparative Alternatives Evaluation

A comparative evaluation of the alternatives is provided in Table 4-6. The subsequent sections provide additional information in terms of engineering, socioeconomic, environmental, physical, traffic, and safety impacts, as well as cost estimates for each of the Build Alternatives.

Table 4-6: Evaluation Matrix

Evaluation Parameters	Build Alternatives		No-Build Alternative
	1	2	
<b>Purpose and Need</b>			
Meets Purpose and Need	✓	✓	✗
<b>Traffic Effectiveness</b>			
Meets Future Traffic Operation Needs	✓	✓	✗
Improves Regional Connectivity	✓	✓	✗
Improves Travel Times	✓	✓	✗
Improves Safety by Reducing Congestion	✓	✓	✗
Reduces Vehicle Conflicts at Intersections	✓	✓	✗
Improves Emergency Response Time and Evacuation	✓	✓	✗
<b>Potential Right-of-Way Impacts</b>			
Right of Way Required (acres)	202.3	189.8	0.0
Number of Parcels Impacted	93	90	0
Number of Potential Residential Relocations	1	1	0
Number of Potential Non-Residential Relocations	0	0	0
<b>Natural/Cultural/Physical Environmental Effects</b>			
Known Previously Recorded National Register Eligible Archaeological Sites Effectuated	0	0	0
Known Previously Recorded National Register Eligible Historic Sites Effectuated	0	0	0
Potential Noise Impacts	Moderate	Moderate	N/A
Air Quality Effects	None	None	None
Wetland Direct Impacts (acres)	141.68	133.27	0
Wetland Secondary Impacts (acres)	132.50	118.89	0
Wetland Median Impacts (acres)	21	N/A	N/A
Transmission Pole Relocation Wetland Direct Impacts	1	3	0
Floodplain Impacts (acres)	120.53	103.57	0
Protected Species Involvement	High	High	None
Conservation Easement Impacts (acres)	64.19	58.91	0.0
Potential Utility Impacts	Yes	Yes	No
Potential Contamination Sites (medium or high)	2	2	0
<b>Estimates in 2021 Present Day Costs (\$ millions)</b>			
Construction (Includes portion of I-4 BtU)	\$1,429.30	\$1,525.07	\$0.00
Right-of-Way	\$94.91	\$86.58	\$0.00
Final Design (10%)	\$142.93	\$152.51	\$0.00
Construction Engineering and Inspection (10%)	\$142.93	\$152.51	\$0.00
Wetland and Protected Species Mitigation	\$29.07	\$27.84	\$0.00
<b>Total Costs (\$ millions)</b>	<b>\$1,839.14</b>	<b>\$1,944.51</b>	<b>\$0.00</b>



#### *4.6.1 Geometric Characteristics*

Mainline Poinciana Parkway (SR 538) and SR 429 are designed for 70 mph and the direct connect ramps at the I-4 Interchange are designed for 50 mph.

The bifurcated configuration in Alternative 1 uses a curvilinear alignment for the northbound lanes of Poinciana Parkway (SR 538) to travel around the FGT/Gulfstream facilities. This curvilinear alignment requires three horizontal curves with superelevation rates that exceed the FTE preferred maximum value of 5%. These curves use superelevation rates between 7.3% and 8.8%.

Alternative 2 provides a straighter alignment for Poinciana Parkway (SR 538) and all the curves between CR 532 and the I-4 interchange use superelevation rates of less than 5%.

Following the Highway Safety Manual procedure from the Federal Highway Administration, it is expected that the more curvilinear alignment on Alternative 1 will yield a higher number of crashes when compared to the Alternative 2 alignment.

#### *4.6.2 Utility Impacts*

Based on the two Build Alternatives, impacts to major UAOs were evaluated. The main UAOs considered are: FGT (Gas), Gulfstream (Gas), Sabal Trail (Gas), Kinder Morgan (Jet Fuel), and Duke Transmission (Electric).

FGT and Gulfstream share a property at the SE quadrant of the interchange, where they house major distribution and compression facilities for their gas transmission operations. In addition, there are multiple gas main pipelines that enter and exit this property to service their customers.

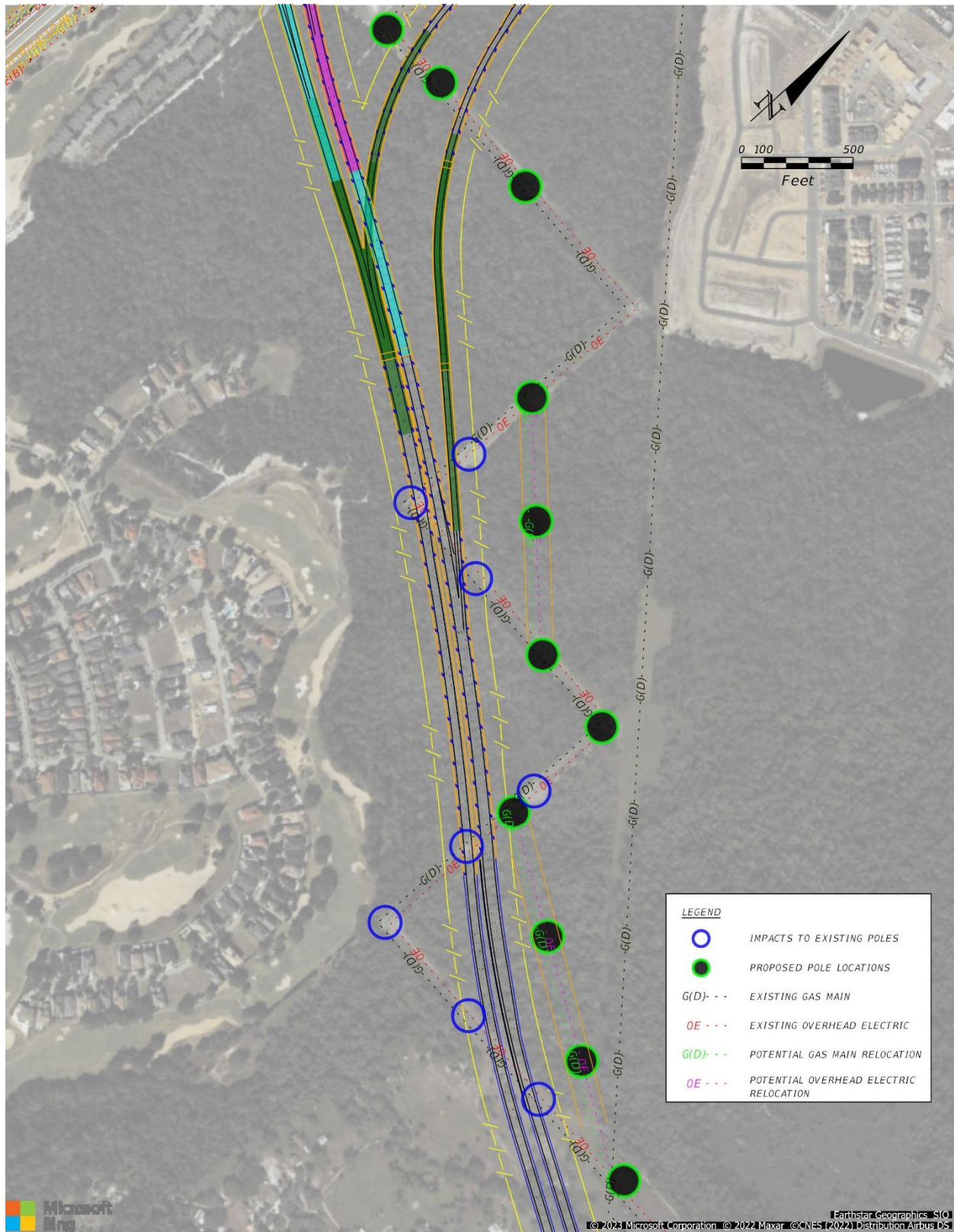
Sabal Trail has a gas main running north-south along the eastern side of the interchange. Kinder Morgan and Duke Transmission share the “stair step” easement with a jet fuel line and high voltage electrical transmission lines.

Table 4-7 describes the utility conflicts that have been identified with both alternatives. Both Alternatives would likely require the relocation of gas and overhead electric facilities within the “stair step” easement (see Figure 4-36). With the PPEC crossing through the utility easement, the UAOs would not be able to access their facilities on the west side of corridor. In addition, overhead electric poles would be directly impacted. Figure 4-36 illustrates the potential relocation of these utilities to the east side of PPEC. This option has not been coordinated with the UAOs but is used to illustrate the extent of impacts. The final extent of the impacts and possible relocations will be established in coordination with each UAO during the design phase.

Table 4-7: Potential Utility Conflicts

Alternative 1	Alternative 2
Has larger footprint over the entrance to the FGT Facility.	Has a smaller footprint over the entrance to the FGT Facility.
May require a relocation of one of the FGT buildings.	Does not require relocation of the FGT buildings.
Northbound lanes of Poinciana Parkway (SR 538) are within the Gulfstream Tower fall radius. This may trigger a relocation of the tower.	All facilities are outside of the Gulfstream Tower fall radius.
Has two direct FGT gas main impacts	Does not have direct FGT gas main impacts
Crosses over Sabal Trail gas main at two locations	Crosses over Sabal Trail gas main at one location
Directly impacts eight Duke Transmission Towers	Directly impacts six Duke Transmission Towers

Figure 4-36: Potential Utility Impacts



### 4.6.3 *Drainage*

The alignment for Alternative 2 crosses Davenport Creek and the Davenport Creek Tributaries nearly perpendicular. This decreases the impacts to the existing flow regime by minimizing the number of piers within the waterway and significantly reduces the need to realign and reconfigure the existing waterways. In addition, Alternative 2 reduces the number of large cross culverts that would need to be relocated under the interchange ramps and I-4 mainline due to the proposed pier columns associated with the new flyover ramps. These conflicts were discussed with the bridge designers, and it was determined that relocating the culverts was the most economical solution. One advantage that Alternative 1 has over Alternative 2 is within the bifurcation area itself. This large area could be used for stormwater management facilities and floodplain compensation.

Anticipated floodplain encroachment for Alternative 1 is 120.53-acres and Alternative 2 is 103.57-acres.

### 4.6.4 *Environmental Impacts*

This section summarizes the results of the natural resources data collection with regards to wetlands and how direct and secondary impacts were calculated.

Environmental scientists, familiar with Florida's natural communities, conducted field reviews of the study area on September 27, 2021, October 25-28 and 30, 2021. Field reviews consisted of pedestrian transects throughout natural habitat types found within the study area. The purpose of the reviews was to verify and/or refine preliminary habitat boundaries and classification codes established through in-office literature reviews and aerial photo interpretation.

Based on collected field data and in-house reviews, forested, herbaceous and shrub wetlands and surface waters were observed within the study area. The wetland types were classified as mixed wetland hardwoods, cypress, hydric pine flatwoods, wetland forested mixed, vegetated non-forested wetlands, shrub wetlands, freshwater marshes, and emergent aquatic vegetation. The surface water types included reservoirs.

Direct impacts were assessed using the proposed ROW width for each alternative assuming the wetland areas in this area would be filled. Areas within the proposed ROW that have elevated sections over wetlands were still considered as a direct impact because the specific bridge configuration impacts are not known at this time.

Secondary impacts refer to indirect effects from project activities on the remaining wetlands within or adjacent to each roadway alternative. These include factors that may change the quality of the wetland in relation to location and wildlife usage, hydrology, or vegetative composition including but are not limited to habitat and wetland fragmentation, light intrusion, and exotic vegetation presence. A secondary assessment area of 150 feet from the edge of any direct wetlands impacts was used. The proposed roadway alignments include bridged sections that would allow for habitat



connectivity to remain, allowing for wildlife movement to continue but at a reduced level compared to its current condition. The hydrologic connection across wetland systems is also reduced at an indirect level but is not completely removed due to the elevated bridged sections that allow the flow of water to continue.

To determine the distance of light intrusion emitting from the proposed roadway, the type of lighting and distance it extends outward to the undeveloped areas was considered. A lighting analysis assuming conventional lighting with light poles mounted at 50 feet, found the maximum distance of 0.5 footcandle (FC) (dim lighting) at 61 feet. At 150 feet from bridge, the lighting was recorded at 0.1 FC. With regard to the intrusion of exotic species as a result of edge effects, the distance exotic species are present from the disturbed edge decreases as the distance from the edge increases. A distance of 150 feet from the alignment edge is likely to have a very low amount of exotic species present when there is an established forested system with little exotics present prior to the proposed roadway impacts. For these reasons, assessing secondary impacts from the limits of the direct wetland impacts outward to 150 feet is anticipated to be sufficient to capture the effects of impacts on wildlife usage, hydrology and vegetative composition.

Alternative 1 would have 142 acres of direct wetland impacts, 133 acres of secondary wetland impacts, and 21 acres of median wetland impacts. Alternative 1 would result in one acre of direct wetland impacts due to transmission pole relocations.

Alternative 2 would have 131 acres of direct wetland impacts on wetlands and 119 acres of secondary wetland impacts. Alternative 2 would result in three acres of direct wetland impacts due to transmission pole relocations.

Other environmental items considered were:

- Conservation easements are located within the project study area. Wetland conservation easement impacts are approximately 65 acres for Alternative 1 and 59 acres for Alternative 2.
- Alternative 1 would impact 120.53 acres of floodplains and Alternative 2 would impact 103.57 acres of floodplains.
- Coordination with USFWS for potential species involvement was held in October 2020 and October 2021. Both alternatives overlap potential scrub-jay and sand and blue-tail mole skink habitat. A Florida scrub-jay survey was conducted in optimal scrub-jay habitat in October 2021 and no individuals were observed. Both Alternatives 1 and 2 are anticipated to have high involvement for sand and blue-tail mole skink due to observation of sand skink tracks within the project study area. Alternative 1 would impact 310 acres sand skink habitat and Alternative 2 would impact 313 acres of sand skink habitat. Mitigation for this species is anticipated to be \$9.30 million for Alternative 1 and \$9.39 million for Alternative 2. It is anticipated that the effect determination for this species would be “may affect, likely

to adversely affect” and a sand skink coverboard survey will be conducted during the design phase.

- Neither Alternative 1 nor 2 would have any impacts to known previously recorded National Register Eligible Archaeological or Historic Sites.
- Alternative 1 and 2 would impact four contamination sites with a medium risk potential.

#### *4.6.5 Stakeholder Input*

The two proposed alternatives have been coordinated with stakeholders along the corridor.

##### Reunion Community Development District

Reunion representatives expressed their understanding of the need for this project and indicated their concerns in the following areas:

- Proximity to their properties
- Elevation of the proposed improvements
- Increased noise

Alternative 2 is approximately 100 feet further from the Reunion development than Alternative 1.

##### Reedy Creek Improvement District (RCID)

RCID indicated that they would like for the proposed improvements to be outside of their conservation area. RCID’s conservation area is outside of District proper, and it is within the county limits.

It is expected that both alternatives will impact the conservation area approximately the same amount. Even though Alternative 1 aligns the roadway further into the conservation area, Alternative 2 is proposing ponds in that area.

##### Osceola County School District

The School District began construction on the Celebration Island Village Elementary School in May 2022. Based on the coordination meeting and subsequent CADD files provided by the School District, the proposed improvements for both alternatives do not impact the school property or their proposed improvements.

##### Celebration Island Village Development

Celebration Island representatives have expressed their concern on how the proposed alternatives impact their current and future development plans.

Although both alternatives do not directly impact proposed home sites, Alternative 1 proposes an alignment that is closer (by approximately 450 feet) to the community and directly impacts future pond sites. Alternative 2 stays further away from the development (reducing noise and air quality concerns) and it does not directly impact their proposed improvements.

4.6.6 Comparison of Advantages and Disadvantages

Table 4-8 includes highlights of the overall evaluation matrix with a focus on significant differences between the two alternatives to identify advantages and disadvantages of each alternative.

Table 4-8: Comparison of Advantages and Disadvantages

Alternative 1	Alternative 2
Advantages	Advantages
<ul style="list-style-type: none"> <li>• Lower construction cost</li> <li>• Lower total cost</li> <li>• Bifurcated area provides room for drainage ponds</li> </ul>	<ul style="list-style-type: none"> <li>• Requires less ROW</li> <li>• Less impacts to FGT (preferred by FGT)</li> <li>• Less impacts to Sabal Trail gas main</li> <li>• Improvements are outside of the Gulfstream’s tower fall radius</li> <li>• Impacts less wetlands</li> <li>• Impacts less conservation easement acreage</li> <li>• Provides more separation to the Reunion Development by 86 feet</li> <li>• Provides more separation to Celebration Island Village by 490 feet</li> <li>• Crosses Davenport Creek and the Tributaries almost perpendicular</li> <li>• Provides straighter alignment</li> </ul>
Disadvantages	Disadvantages
<ul style="list-style-type: none"> <li>• Requires more ROW</li> <li>• May require relocation of an FGT building</li> <li>• Improvements are within the Gulfstream’s tower fall radius</li> <li>• Directly impacts two FGT gas main lines</li> <li>• Impacts more wetlands</li> <li>• Impacts more conservation easement acreage</li> <li>• Crosses Davenport Creek and the Tributaries at a skewed angle requiring additional bridge piers</li> <li>• Closer to the Reunion Development by 86 feet</li> <li>• Closer to Celebration Island Village by 490 feet</li> </ul>	<ul style="list-style-type: none"> <li>• Higher construction cost</li> <li>• Higher total cost</li> </ul>

#### 4.7 Selection of the Preferred Alternative

Alternative 2 is recommended as the Preferred Alternative for the following reasons:

- Alternative 2 requires less ROW and has a smaller footprint than Alternative 1, reducing impacts. Alternative 1 has more direct wetland impacts than Alternative 2. Secondary impacts for each alternative were also assessed within 150 feet of the direct impacts. The combined direct and secondary impacts are greater in Alternative 1.
- Alternative 2 is preferred by FGT over Alternative 1 due to fewer impacts to their facility. Additionally, Alternative 2 does not have direct impacts to FGT's Gas Mains.
- Alternative 2 has lower ROW cost. While it has a higher construction cost than Alternative 1 (as well as a higher total cost), the following was considered:
  - Alternative 1 has direct gas main impacts that do not occur with Alternative 2 (the actual cost of the gas main relocation has not been determined, as they required evaluation by the gas companies).
  - Possible refinements only applicable to the Alternative 2 design may assist with lowering and shortening some of the bridges and thus reducing the project construction cost.
- Alternative 2 is located further away from the Celebration Island Village residential lots (approximately 600 feet) than Alternative 1 (approximately 110 feet).
- Alternative 2 is located further away from the Reunion Development (approximately 605 feet) than Alternative 1 (approximately 519 feet).
- Alternative 2 allows a more perpendicular crossing of Davenport Creek, reducing the creek realignment, number of bridge piers in the water and reducing the impact to the creek flows.



## 5.0 PROJECT COORDINATION & PUBLIC INVOLVEMENT

### 5.1 Agency Coordination

Agency coordination has occurred throughout the PD&E phase of the project and will continue as the project moves forward into subsequent design and construction phases. Agency coordination documentation will be included in the *Comments and Coordination Report*, prepared as a supporting document to this study. Listed below is a history of the events to date:

- Advance Notification and ETDM – May 29, 2020
- CFX Coordination – July 17, 2020
- FDOT District Five Coordination – March 11, 2021
- CFX Coordination – March 30, 2021
- Osceola County Coordination – April 20, 2021
- Federal Highway Administration (FHWA) Coordination – May 19, 2021
- FGT and Gulfstream Utility Coordination – January 31, 2022

### 5.2 Public Involvement

Public outreach and involvement are important to the success of the project. This outreach effort will continue as the project moves forward into subsequent phases. The *Comments and Coordination Report* includes documentation of the items listed below. Listed below is a history of the public outreach events to date:

- Newsletter prepared and distributed – June 3, 2021
- Hybrid Public Kickoff Meeting – June 22, 2021 from 5:00 PM to 7:30 PM (virtual) and June 24, 2021 from 5:00 PM to 7:30 PM (in person). Notification letters were mailed to 2,718 addresses and an additional 163 e-mail notifications were sent to elected and appointed officials, tribes and interested parties/organizations. The project information was presented and displayed for the public and agencies in attendance, along with a PowerPoint presentation, at the virtual meeting as well as the in-person meeting at the Nicholson Center, 404 Celebration Place, Celebration, Florida. Project representatives were available to discuss the information presented and answer questions. Fifty-four (54) people attended the virtual meeting which included 21 members of the project team. Thirty-one (31) people attended the in-person meeting which included 20 members of the project team. There were two comments received during the meetings and no additional comments were received during the comment period. All comments were responded to.

- Alternatives Public Information Meeting – February 22, 2022 starting at 5:30 PM (virtual) and February 24, 2022 starting at 5:30 PM (in person). Notification letters were mailed to 2,649 addresses and an additional 143 e-mail notifications were sent to elected and appointed officials, tribes and interested parties/organizations. The project information was presented and displayed for the public and agencies in attendance, along with a PowerPoint presentation, at the virtual meeting as well as the in-person meeting at the Nicholson Center, 404 Celebration Place, Celebration, Florida. Project representatives were available to discuss the information presented and answer questions. Sixty-seven (67) people attended the virtual meeting which included 23 members of the project team. Forty-nine (49) people attended the in-person meeting which included 18 members of the project team. There were 31 comments received during the comment period. Public comments and questions were generally regarding ROW impacts, noise, property values, and environmental impacts.

A number of additional stakeholder and small group meetings were held and are listed below.

- Reedy Creek Improvement District (RCID) - May 19, 2021
- Mattamy Homes and Disney - August 18, 2021
- Reedy Creek Improvement District (RCID) – March 3, 2022
- Reunion Resort – March 10, 2022

## 6.0 DESIGN FEATURES OF THE PREFERRED ALTERNATIVE

After the Alternatives Public Information Meeting and selection of the Preferred Alternative, a Cost Risk and Value Engineering (CRAVE) study was conducted. The CRAVE team developed fourteen Value Engineering recommendations. A memo summarizing the recommendations and decisions by FTE to accept or not accept are provided in Appendix A. Modifications made to the Preferred Alternative are reflected in the sections below.

### 6.1 Engineering Details of the Preferred Alternative

#### *6.1.1 Typical Sections*

Proposed typical sections for the Preferred Alternative are provided in Appendix B.

The proposed typical section for Poinciana Parkway (SR 538) includes a 12-foot wide outside shoulder (10-foot paved), three 12-foot wide travel lanes, and a 12-foot wide inside shoulder (10-foot paved) along both directions of travel. The inside shoulders are part of a 50-foot wide median. The typical section can accommodate eight lanes in the future by widening to the inside. The proposed limited access ROW width is 310 feet.

The proposed typical section for SR 429 includes both C-D and general travel lanes in both directions. The C-D lanes consist of a 12-foot wide outside shoulder (10-foot paved), four 12-foot wide C-D lanes, and a 12-foot wide inside shoulder (10-foot paved). The travel lanes consist of a 12-foot wide outside shoulder (10-foot paved), two 12-foot wide travel lanes, and a 10-foot wide inside paved shoulder with barrier wall. The C-D and travel lanes are separated by a 30-foot wide median. A minimum 26-foot wide median separates NB and SB traffic. The proposed limited access ROW is 510 feet. Additional ROW needs vary from 0 to 207 feet along SR 429.

The proposed typical section for I-4 along each direction of travel includes a concrete shoulder barrier, 12-foot wide outside shoulders, four 12-foot wide general use lanes, a four-foot-wide buffer, two 12-foot wide managed lanes, a 10-foot wide inside paved shoulder, and a concrete shoulder barrier wall. The inside shoulders are part of a 64-foot wide median that also includes 44 feet for a potential rail corridor. Segments of I-4 are proposed to use barrier walls to separate the general use lanes from the managed lanes. Barrier walls would be needed to accommodate the placement of supporting columns for the Poinciana Parkway (SR 538)/I-4/SR 429 interchange ramps.

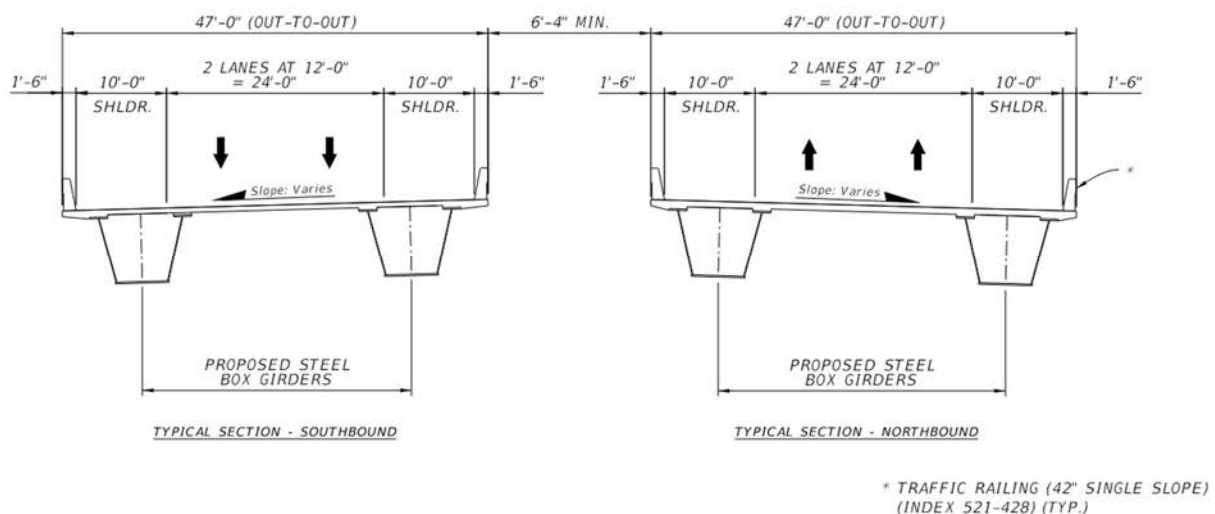
## 6.1.2 Bridges and Structures

### 6.1.2.1 Interchange Bridges

The preferred alternative proposes that both northbound and southbound Poinciana Parkway (SR 538) are located south of the FGT/Gulfstream station. The structures proposed to be constructed throughout the corridor will meet minimum vertical clearance per FDM 260. Bridge lengths were established such that MSE wall heights do not exceed 40 feet.

The Poinciana Parkway (SR 538) bridges that tie-in to SR 429 will carry two 12-foot wide southbound lanes and two 12-foot wide northbound lanes through the interchange with varying auxiliary lanes throughout the bridge limits. Northbound and southbound Poinciana Parkway (SR 538) over I-4 will utilize steel box girders. As Poinciana Parkway (SR 538) moves south and away from the interchange, the bridges can transition from steel box girders to prestressed concrete beams for the Davenport Creek crossing. Northbound Poinciana Parkway (SR 538) is anticipated to have 12 steel box girder spans crossing Ramp B2, I-4, and S. Old Lake Wilson Road, and 17 prestressed concrete I-beam spans crossing Ramp D2 and Davenport Creek. Southbound Poinciana Parkway (SR 538) is anticipated to have 13 steel box girder spans crossing Ramp B2, I-4, and S. Old Lake Wilson Road, and 14 prestressed concrete I-beam spans crossing Davenport Creek. For the proposed typical sections for SR 429, see Figures 6-1 and 6-2.

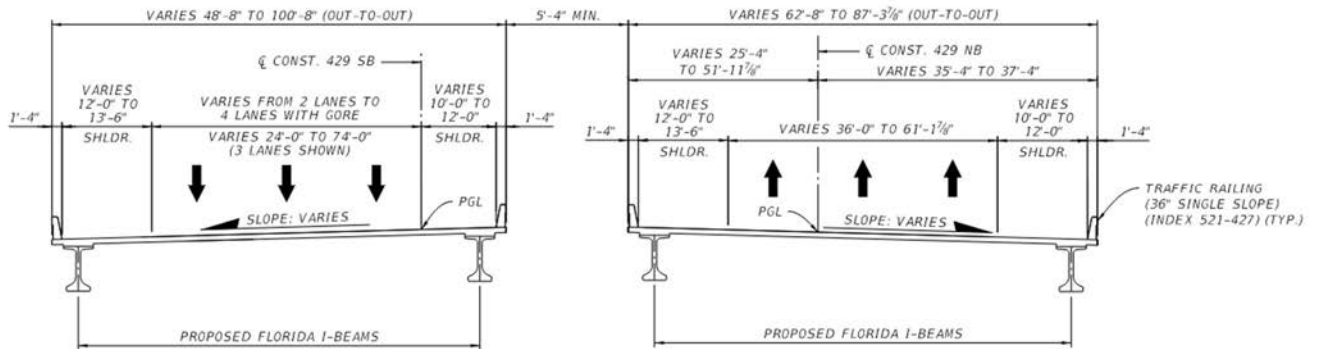
Figure 6-1: Bridge Typical Section for Poinciana Parkway (SR 538) over I-4





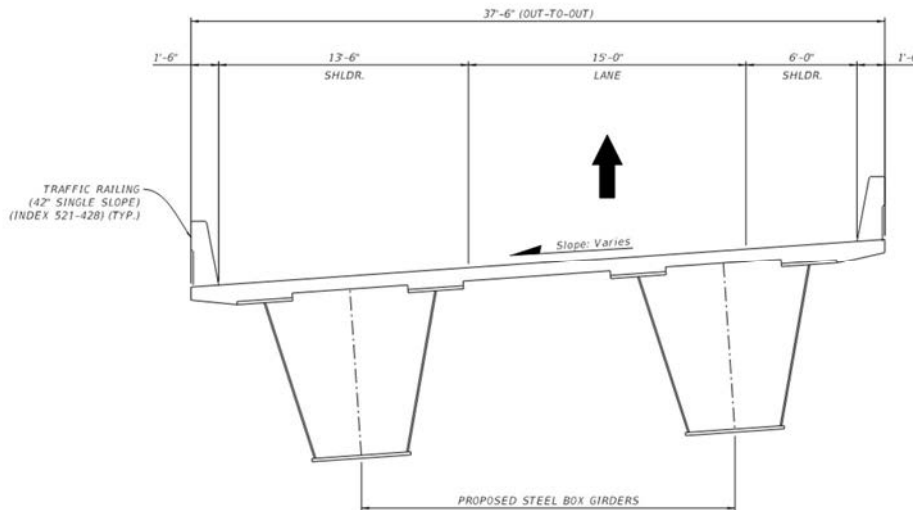
SECTION 6 – DESIGN FEATURES OF THE PREFERRED ALTERNATIVE

Figure 6-2: Bridge Typical Section for Poinciana Parkway (SR 538) over Davenport Creek



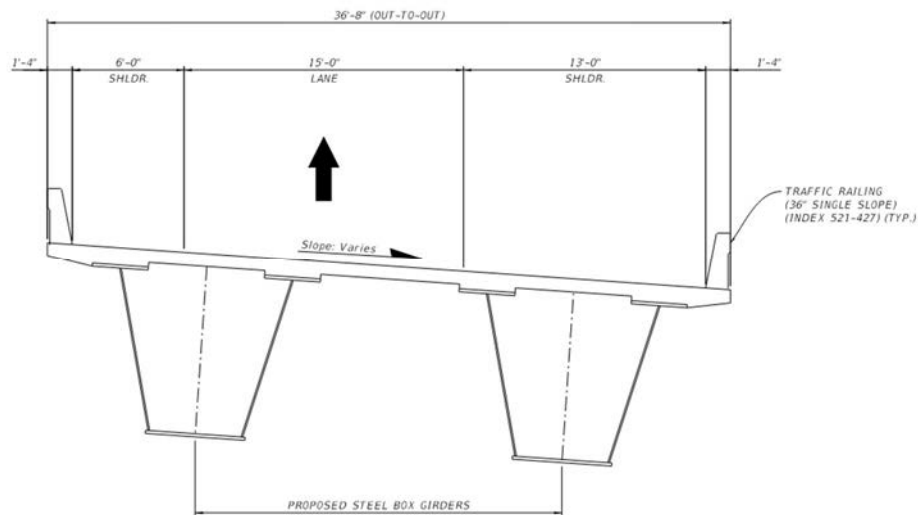
Ramp A1 is the proposed fourth level ramp carrying northbound Poinciana Parkway (SR 538) traffic to the I-4 westbound lanes. The proposed bridge typical section will consist of one 15-foot wide lane with a 13.5-foot wide inside shoulder for stopping sight distance around the curve and a 6-foot wide outside shoulder. The proposed structure is anticipated to be 12 steel box girder spans crossing S. Old Lake Wilson Road, southbound Poinciana Parkway (SR 538), Ramp B2, I-4, Ramp A2, and Ramp A3. For the proposed typical section for Ramp A1, see Figure 6-3.

Figure 6-3: Typical Section for Ramp A1



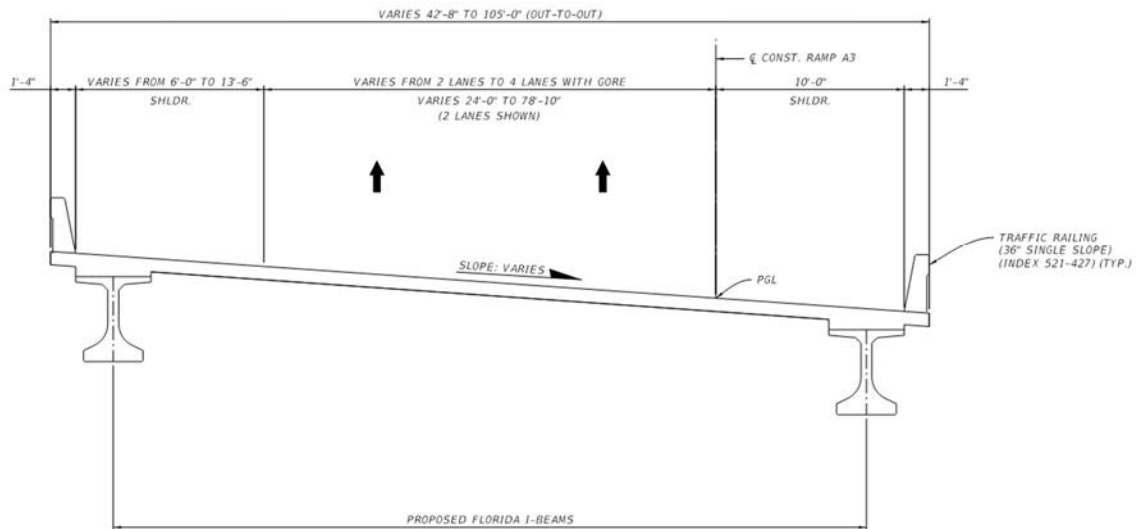
Ramp A2 is the proposed second level ramp carrying southbound SR 429 traffic to the I-4 westbound managed lanes. The proposed bridge will consist of one 15-foot wide lane with a 6-foot wide inside shoulder and a 13-foot wide outside shoulder for sight distance around the curve. The proposed structure is anticipated to be five steel box girder spans crossing westbound I-4 and a pond. For the proposed typical section for Ramp A2, see Figure 6-4.

Figure 6-4: Typical Section for Ramp A2



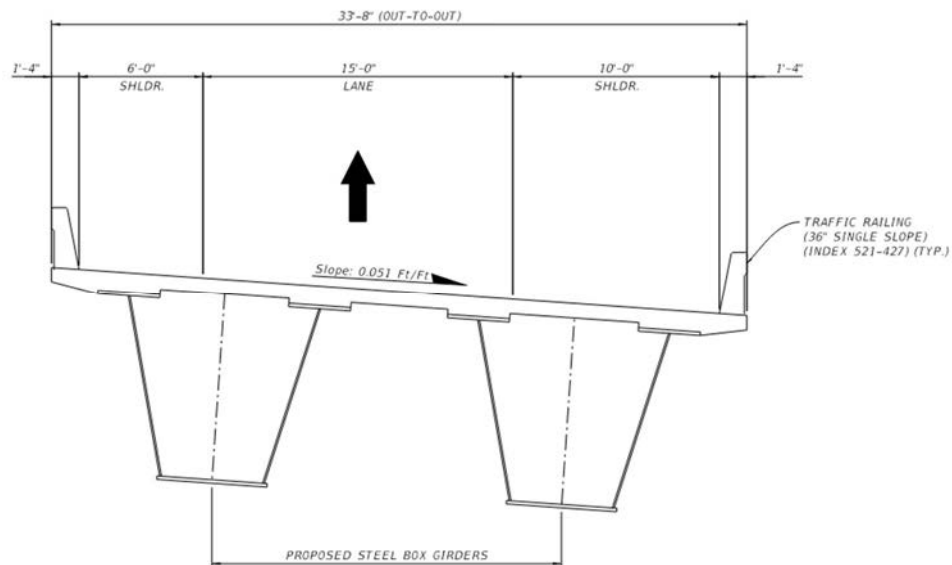
Ramp A3 is the proposed second level ramp carrying southbound SR 429 traffic to the I-4 westbound lanes. The travel lanes on the bridge will vary from two 12-foot wide lanes to four 12-foot wide lanes. The proposed bridge will have an inside shoulder that varies from 6 to 10-foot wide and a 10-foot wide outside shoulder. The proposed structure is anticipated to be 13 prestressed concrete I-beam spans crossing a pond. For the proposed typical section for Ramp A3, see Figure 6-5.

Figure 6-5: Typical Section for Ramp A3



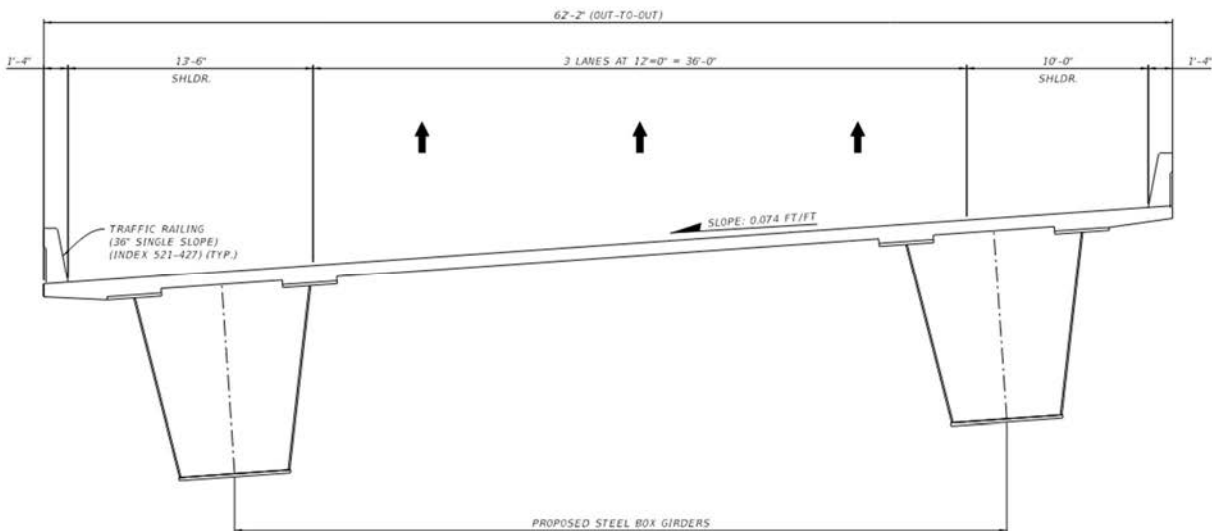
Ramp B1 is the proposed second level ramp carrying I-4 eastbound managed lanes traffic to northbound SR 429. The proposed bridge will carry one 15-foot wide lane with a 6-foot wide inside shoulder and a 10-foot wide outside shoulder for stopping sight distance around the curve. The proposed structure is anticipated to be three steel box girder spans crossing eastbound I-4. For the proposed typical section for Ramp B1, see Figure 6-6.

Figure 6-6: Typical Section for Ramp B1



Bridge 920601 (Ramp B) connects eastbound I-4 traffic to northbound SR 429. The existing bridge is within the SR 429 interchange and is proposed to be replaced to accommodate three 12-foot wide lanes with a 13.5-foot wide inside shoulder for stopping sight distance around the curve and 10-foot wide outside shoulder and a change from third level to second level. The replacement structure, Ramp B2, is located east of the existing flyover. The horizontal alignment was set to avoid impacts to the existing bridge while also minimizing the distance to tie back into the existing offramp. The span arrangement was developed to avoid piers in the I-4 median. The proposed structure is anticipated to be five steel box girder spans crossing I-4 and Ramp B3. For the proposed typical section for Ramp B2, see Figure 6-7.

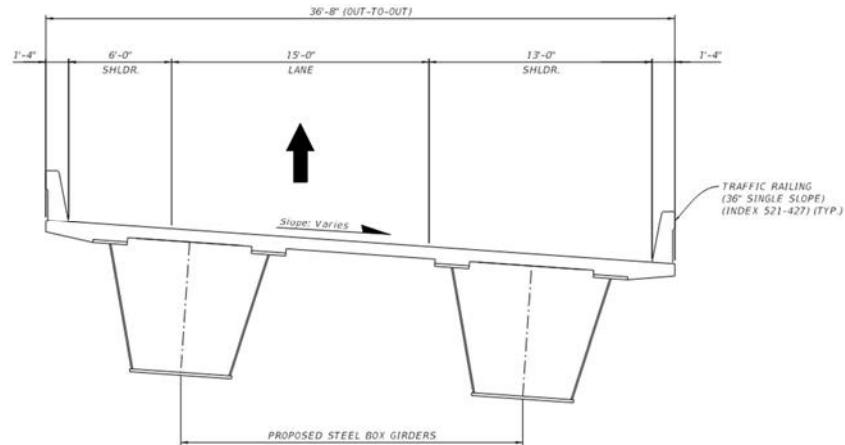
Figure 6-7: Typical Section for Ramp B2



Ramp B3 is the proposed second level ramp carrying eastbound I-4 traffic to southbound Poinciana Parkway (SR 538). The proposed bridge will carry one 15-foot wide lane with a 6-foot wide inside shoulder and a 13-foot wide outside shoulder for stopping sight distance around the curve. The proposed structure is anticipated to be six steel box girder spans crossing S. Old Lake Wilson Road, Davenport Creek Tributary No. 3, and a pond. For the proposed typical section for Ramp B3, see Figure 6-8.

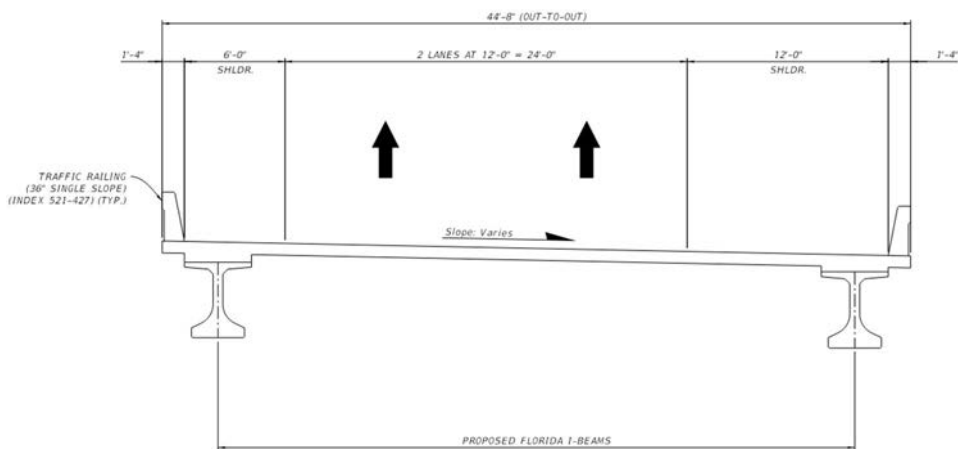


Figure 6-8: Typical Section for Ramp B3



Ramp C1 is a proposed low-level ramp carrying northbound Poinciana Parkway (SR 538) traffic to eastbound I-4. The proposed bridge will carry two 12-foot wide lanes with a 6-foot wide inside shoulder and 12-foot wide outside shoulder. The proposed structure is anticipated to be seven prestressed concrete I-beam spans crossing Davenport Creek. For the proposed typical section for Ramp C1, see Figure 6-9.

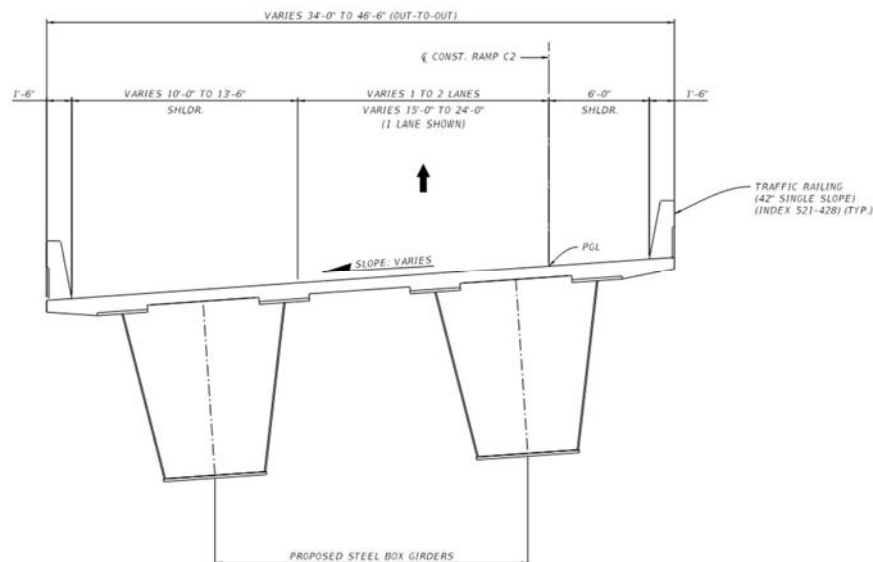
Figure 6-9: Typical Section for Ramp C1



Bridge 920602 (Ramp C) connects southbound SR 429 traffic to eastbound I-4. The existing bridge is a second level within the SR 429 interchange and is proposed to be replaced with a fourth level bridge. The proposed bridge typical section will consist of a transition from two 12-foot wide lanes

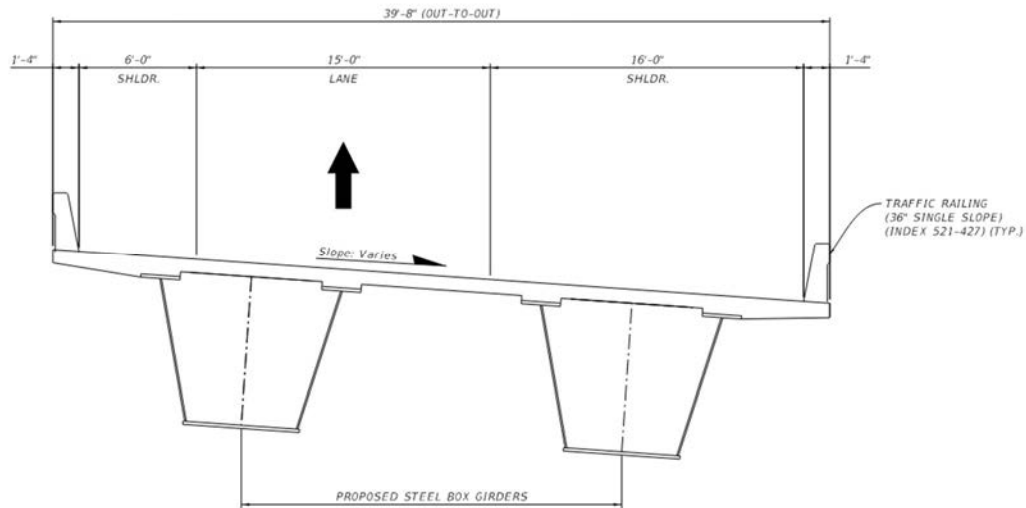
to one 15-foot wide lane with an inside shoulder varying from 10-foot wide to 13.5-foot wide for stopping sight distance around the curve and a 6-foot wide outside shoulder. The replacement structure, Ramp C2, is located north of the existing bridge. The horizontal alignment was set to avoid impacts to the existing bridge and maintain traffic during construction. The span arrangement was developed to avoid piers in the I-4 median. The proposed structure is anticipated to be 18 steel box girder spans crossing multiple ponds, Poinciana Parkway (SR 538), S. Old Lake Wilson Road, Ramp D2, Ramp C3, and Ramp C1. For the proposed typical section for Ramp C2, see Figure 6-10.

Figure 6-10: Typical Section for Ramp C2



Ramp C3 is the proposed second level ramp carrying traffic from northbound Poinciana Parkway (SR 538) to eastbound I-4 managed lanes. The proposed bridge will carry one 15-foot wide lane with a 6-foot wide inside shoulder and a 16-foot wide outside shoulder for stopping sight distance around the curve. The proposed structure is anticipated to be five steel box girder spans crossing eastbound I-4. For the proposed typical section for Ramp C3, see Figure 6-11.

Figure 6-11: Typical Section for Ramp C3



Ramp D1 is the proposed second level ramp carrying traffic from westbound I-4 managed lanes to southbound Poinciana Parkway (SR 538). The proposed Ramp D1 bridges will carry one 15-foot wide lane with 6-foot wide inside and outside shoulders. The first proposed structure is anticipated to be two steel box girder spans crossing westbound I-4. The second proposed structure is anticipated to be four prestressed concrete I-beam spans over a pond. For the proposed typical sections for Ramp D1 over westbound I-4 and Ramp D1 over Pond, see Figures 6-12 and 6-13.

Figure 6-12: Typical Section for Ramp D1 over Westbound I-4

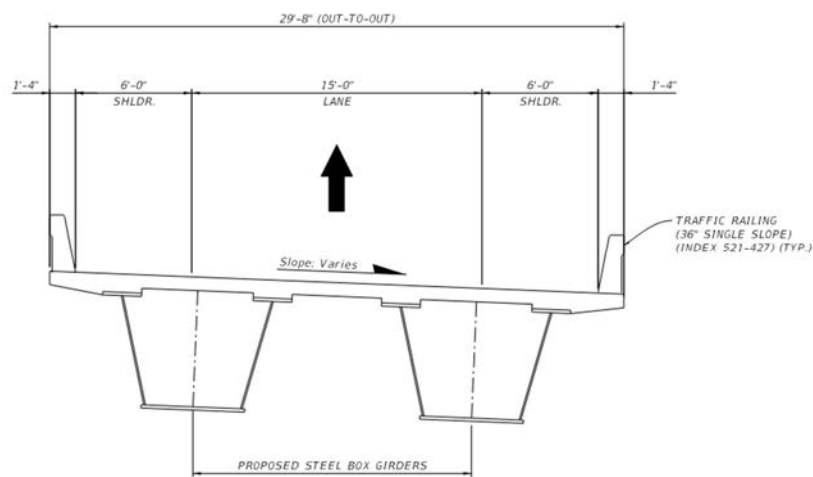
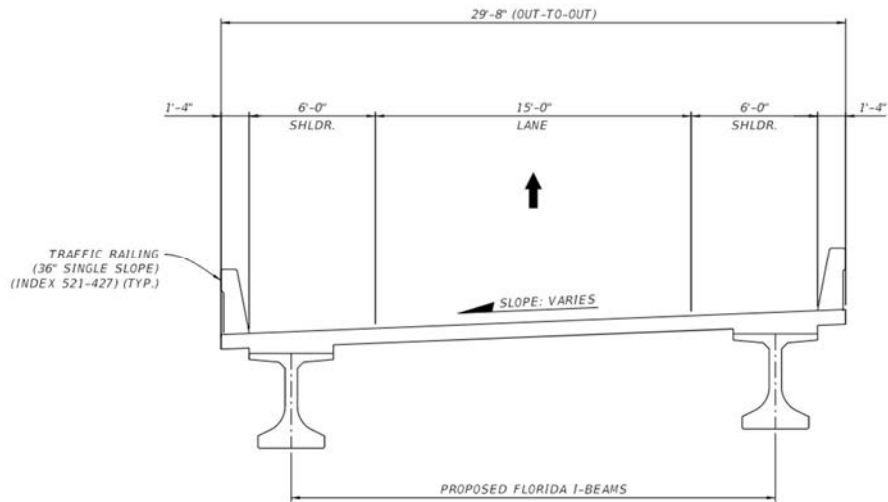


Figure 6-13: Typical Section for Ramp D1 over Pond



Ramp D2 at I-4 is the proposed second level ramp carrying traffic from the westbound I-4 general use lanes and managed lanes to southbound Poinciana Parkway (SR 538). The proposed bridge will carry three 12-foot wide lanes with a 12-foot wide inside shoulder and 10-foot wide outside shoulder. The proposed structure is anticipated to be five steel box girder spans crossing I-4. Where Ramp D2 connects with southbound Poinciana Parkway (SR 538), the low-level crossing over Davenport Creek will carry two 12-foot wide lanes with a 12-foot wide inside shoulder and 10-foot wide outside shoulder. The Ramp D2 over Davenport Creek structure is anticipated to be three prestressed concrete I-beam spans. For the proposed typical sections for Ramp D2 over I-4 and Ramp D2 over Davenport Creek, see Figures 6-14 and 6-15.

Figure 6-14: Typical Section for Ramp D2 over I-4

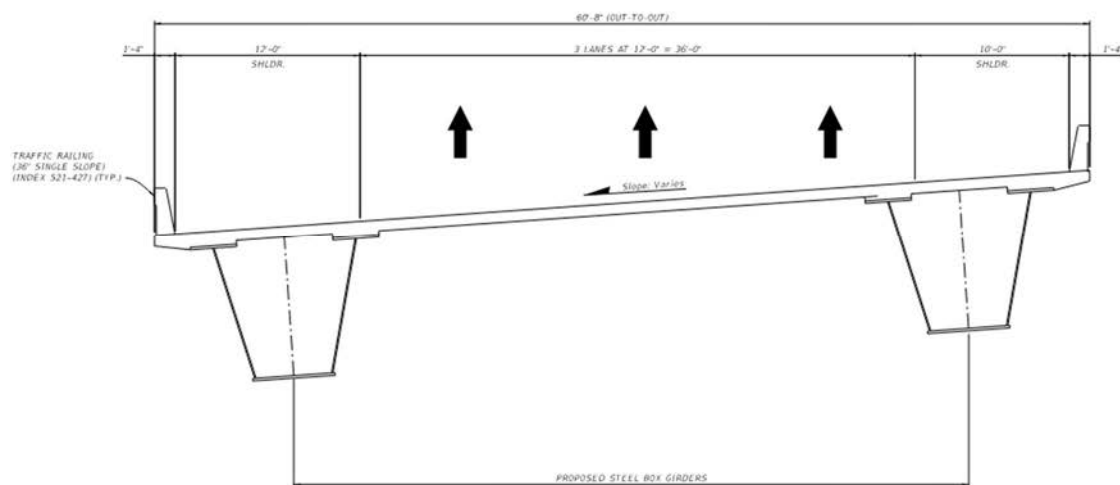
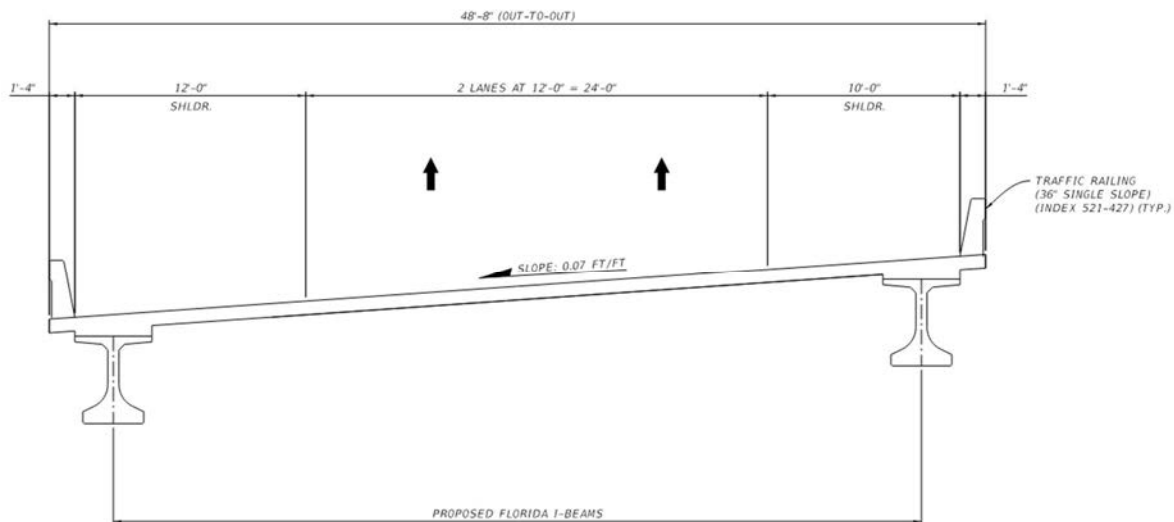




Figure 6-15: Typical Section for Ramp D2 over Davenport Creek

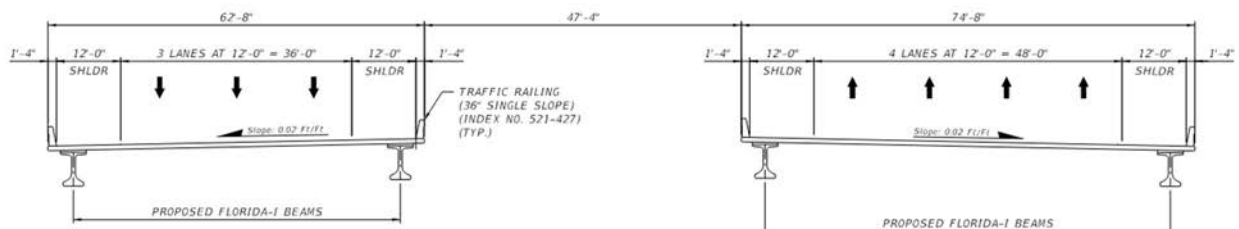


A single straddle bent will be utilized for Ramps A2, B1, C3, and D1 bridge configurations. These bridges provide connections to the proposed I-4 BtU managed lanes. Additionally, two straddle bents are anticipated for the northbound Poinciana Parkway (SR 538) bridges: one over Ramp D2 and the other over Ramp B2. One integral pier cap is anticipated on Ramp B1. Three integral pier caps are anticipated on Ramp B2.

6.1.2.2 County Road 532

Two proposed parallel bridges will carry the extension of Poinciana Parkway (SR 538) over CR 532. The proposed structures are anticipated to be single span bridges utilizing prestressed concrete I-beams. The proposed northbound bridge will be designed to carry four 12-foot wide lanes with 12-foot wide inside and outside shoulders. The proposed southbound bridge will be designed to carry three 12-foot wide lanes with 12-foot wide inside and outside shoulders. For the proposed typical section for Poinciana Parkway (SR 538) over CR 532, see Figure 6-16.

Figure 6-16: Typical Section for Poinciana Parkway (SR 538) over CR 532



SECTION 6 – DESIGN FEATURES OF THE PREFERRED ALTERNATIVE

6.1.2.3 Sinclair Boulevard

The proposed SR 429 mainline configuration maintains the existing Sinclair Boulevard bridge over SR 429. Vertical clearance over SR 429 is sufficient. For the proposed SR 429 configuration, the existing bridge abutments and piers are within the clear zone and will require barrier protection; however, pier protection is not required.

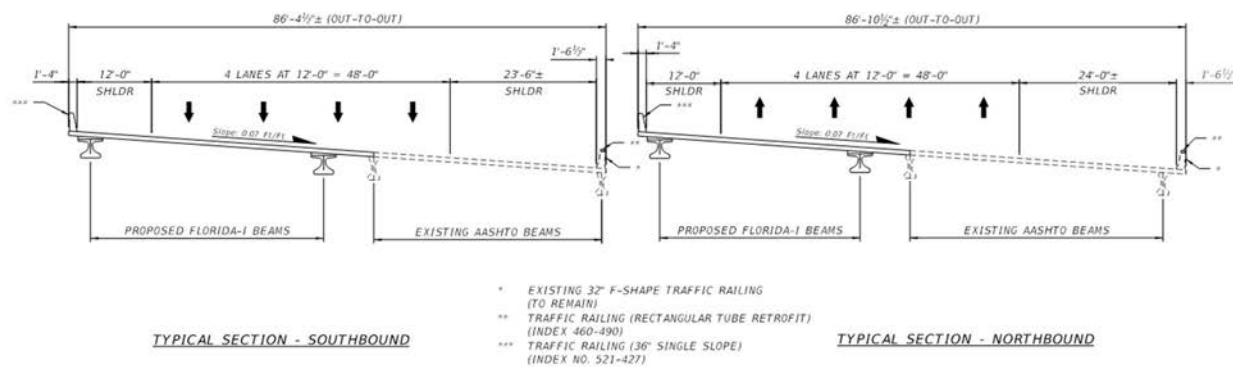
6.1.2.4 Tradition Boulevard

The proposed I-4 mainline configuration maintains the existing Tradition Boulevard bridge over I-4. Vertical clearance over I-4 is sufficient. The north abutment is within the clear zone and will require barrier protection. Additionally, a new retaining wall may be required to accommodate grading for the proposed I-4 widening. The south abutment is outside the clear zone but may require a new retaining wall to accommodate grading for the proposed I-4 widening. The proposed I-4 configuration will provide barrier protection for the existing median pier; however, pier protection is not required.

6.1.2.5 Sand Hill Road

The existing northbound and southbound SR 429 single-span bridges over Sand Hill Road are proposed to be widened using prestressed concrete I-beams. The proposed northbound bridge widening will be to the inside resulting in four 12-foot wide lanes, a 24-foot wide outside shoulder and a 12-foot wide inside shoulder. The proposed southbound bridge outside widening will have four 12-foot wide lanes, a 12-foot wide outside shoulder and a 23.5-foot wide inside shoulder. The vertical clearance will remain as-is. For the proposed typical section for SR 429 over Sand Hill Road, see Figure 6-17.

Figure 6-17: Typical Section for SR 429 over Sand Hill Road



### *6.1.3 Right-of-Way and Relocations*

The Preferred Alternative requires 190 acres of ROW from 90 parcels resulting in one residential relocation.

### *6.1.4 Horizontal and Vertical Geometry*

The horizontal geometry data for the project is provided in Appendix C. The proposed interchange at Poinciana Parkway (SR 538)/I-4/SR 429 consists of ramps at multiple levels as indicated in Appendix C.

An analysis of the vertical geometry was conducted to determine required bridge levels. A final determination will be made during the Final Design Phase on whether PPEC goes over Osceola County's proposed Celebration Boulevard or Celebration Boulevard goes over PPEC. Vertical profile sheets, include proposed bridge clearances, are provided in Appendix D.

### *6.1.5 Bicycle and Pedestrian Accommodations*

Poinciana Parkway (SR 538), I-4, and SR 429 are limited access facilities; therefore, the Preferred Alternative does not include bicycle or pedestrian accommodations.

Existing CR 532 does not provide any bicycle or pedestrian accommodations. The Preferred Alternative would accommodate planned improvements to CR 532 by Osceola County that includes bicycle and pedestrian facilities.

The existing Sinclair Road bridge over SR 429 provides pedestrian accommodations and the Preferred Alternative would not impact this bridge.

The existing Traditions Boulevard bridge over I-4 provides pedestrian accommodations and the Preferred Alternative would not impact this bridge.

### *6.1.6 Multi-Modal Accommodations*

Proposed improvements along I-4 include maintaining a 44-ft wide envelop for future rail service within the median. There are no other existing or planned transit services on Poinciana Parkway (SR 538), I-4, or SR 429.

### *6.1.7 Access Management*

As part of a separate effort, CFX is extending Poinciana Parkway (SR 538) to CR 532 and the terminus interchange would include a southbound on ramp and a northbound off ramp. The Preferred Alternative would extend Poinciana Parkway (SR 538) to I-4 and would modify the interchange at CR 532 by removing the southbound on and northbound off ramps and adding northbound on and southbound off ramps.

At the Sinclair Road interchange, the ramp terminal on the west side would change from unsignalized to signalized. The existing ramp terminal on the east side is already signalized.

### *6.1.8 Intersection and Interchange Concepts*

Concept plans are provided in Appendix C.

The proposed interchange at CR 532 is a partial diamond interchange with access to/from the north. The southbound off ramp would provide a single left turn lane and single right turn lane under signal control. The northbound on ramp would provide two receiving lanes under signal control to accommodate left turns from CR 532.

The Poinciana Parkway (SR 538)/I-4/SR 429 interchange provides system-to-system connections between all three facilities. Direction connections from the managed lanes on I-4 would be provided to/from Poinciana Parkway (SR 538) and SR 429.

The Sinclair Road interchange would remain as a diamond interchange with signal control added to the ramp terminals on the west side. The northbound SR 429 off ramp would provide dual left turn lanes, a through lane, and a single right turn under signal control. The southbound off ramp would provide dual left turn lanes and a single right turn under signal control. The southbound SR 429 on-ramp would provide two receiving lanes that merges down to one lane before entering the C-D system. Access to northbound SR 429 from Sinclair Road would be provided from Connector Road just north of the interchange.

### *6.1.9 Intelligent Transportation System and TSM&O Strategies*

The Preferred Alternative would accommodate existing ITS facilities along SR 429 and I-4. ITS improvements along Poinciana Parkway (SR 538) will be further evaluated during the design phase.

No TSM&O strategies were identified as part of the Preferred Alternative.

### *6.1.10 Utilities*

A Utility Assessment Report (August 2022) was prepared to document existing and planned utilities. Twenty-one (21) UAOs were identified as potentially having facilities within the study limits. Follow-up information provided by the identified UAOs resulted in seven UAOs providing information on facilities in the project area, two indicating they have no facilities, and 12 providing no responses. Actual utility impacts will be verified during the design phase when detailed survey information is available.

### *6.1.11 Drainage and Stormwater Management Facilities*

The Preferred Alternative will be designed to meet the regulatory requirements of the applicable water management districts, the requirements outlined in the FDOT Drainage Manual, and the requirements of FTE. The majority of the project is located within the SFWMD jurisdiction; therefore, SFWMD will be the lead permitting agency for the Environmental Resource Permit (ERP). The permit application will be submitted to the RCID for review and comment before submitting to the SFWMD. The RCID will issue approval of the ERP application before it is submitted to the



SFWMD for review and issuance. FDEP will be responsible for Section 404 reviews and permitting. A National Pollutant Discharge Elimination System (NPDES) permit will also be required from FDEP.

An analysis was conducted to determine potential pond requirements. Table 6-1 provide a summary of the basin and approximate ROW needs for ponds. Proposed pond locations are shown in Appendix C. The *Pond Siting Report*, available under separate cover and located in the project file, provides information about proposed pond sizes, slopes, depths, and types of treatment.

Table 6-1: Anticipated Right-of-Way for Preferred Ponds

Basin	Location	Anticipated Pond ROW Requirement (acres)
Basin 100	Within Poinciana Parkway (SR 538)/CR 532 interchange	0.00 (Located within existing ROW)
BSN206	Within Poinciana Parkway (SR 538)/CR 532 interchange	5.64
BSN205	Between CR 532 and I-4	12.18
BSN204	Between CR 532 and I-4	9.97
BSN203	Between CR 532 and I-4	10.81
BSN Interchange	Poinciana Parkway (SR 538)/I-4/SR 429 interchange area	0.00 (Located within existing ROW)
BSN202	Between I-4 and Sinclair Road interchange	5.80
BSN201	SR 429 and Sinclair Road interchange	2.18
BSN200	North of Sinclair Road interchange	2.45
BSN109	East side of I-4/Sr 429 interchange	12.49

#### 6.1.12 Floodplain Analysis

The proposed improvements will require seven new cross culverts for the extension of Poinciana Parkway (SR 538) and five culvert extensions along I-4 and SR 429.

Based on the Federal Emergency Management Agency (FEMA) Flood Insurance Rate Map (FIRM) panels 12097C0040G and 12097C0045G dated June 18, 2003, the proposed corridor traverses multiple floodplains. These floodplains are depicted as Zone AE and Zone A. Davenport Creek is the largest waterway within the project corridor. It has a floodplain designation of Zone AE, as

well as being classified with a regulatory floodway. The Preferred Alternative will encroach into the 100-yr floodplain in a number of locations; however, these encroachments are considered “Minimal Encroachments”. Fourteen (14) floodplain locations would be impacted for a total of 50.74 ac-ft. The encroachments will be offset with minor grading around headwalls and endwalls, replacing side slope embankment with retaining walls, within proposed pond sites, and through dedicated floodplain compensation sites. There will be no significant change in the potential for interruption or termination of emergency service or emergency evacuation routes as the result of construction of this project. Therefore, it has been determined that these encroachments are not significant. Details of the analysis are provided in the *Location Hydraulics Report* available under separate cover.

Anticipated floodplain encroachments are shown in Table 6-2. Mitigation for these encroachments will be provided within dedicated floodplain compensation sites along the corridor.

Table 6-2: Floodplain Encroachments

Location ID	From Station	To Station	Side	Floodplain / Waterbody Name	Floodplain Zone	FEMA 100-yr Floodplain Elevation (ft)	Encroachment Amount (ac-ft)
1	7427+00	7439+00	RT	Davenport Creek Swamp	AE	160.00	0.85
2	6426+00	6435+00	LT	Davenport Creek Swamp	AE	106.00	0.48
3	6391+00	6400+00	LT	Davenport Creek Trib No. 3	A	100.00*	4.13
4	5336+00	5341+00	LT	Davenport Creek Trib No. 3	A	94.50*	0.47
5	5342+00	5344+00	RT	Davenport Creek Trib No. 3	A	94.10*	0.08
6	5359+00	5364+00	RT	Unnamed Davenport Creek Trib	AE	83.00	2.06
7	1035+00	1042+00	RT	Unnamed Davenport Creek Trib	AE	83.00	4.63
8	1028+00	1033+00	LT/RT	Unnamed Davenport Creek Trib	AE	83.00	0.89
9	6307+00	6313+00	LT/RT	Davenport Creek	AE	80.00	2.06
10	6298+00	6307+00	LT/RT	Davenport Creek	A	77.00	0.81
11	6293+00	9298+00	LT/RT	Davenport Creek Trib No. 4	A	77.00	3.86
12	6261+00	6277+00	LT/RT	Davenport Creek/Reedy Creek	A	77.00	19.66
13	6235+00	6247+00	LT/RT	Isolated Wetland	A	83.00*	8.51
14	6223+00	6228+00	LT/RT	Isolated Wetland	A	87.00*	2.25

### *6.1.13 Transportation Management Plan*

Construction activities usually result in traffic disruptions and safety concerns along the roadway work zone. Developing a maintenance of traffic plan that minimizes these disruptions and preserves the safety of the workers and road users within the work zone is paramount to a successful project. For the Preferred Alternative, the project has been divided into five segments. The segment distribution does not indicate the order of construction activities. The segments are:

- Segment 1 – Connection with Poinciana Parkway (CFX Project Number 538-235) to North of CR 532
- Segment 2 – From North of CR 532 to South of I-4/SR 429 Interchange
- Segment 3 – I-4
- Segment 4 – South of I-4/SR 429 Interchange to Sinclair Road
- Segment 5 – SR 429 From Sinclair Road to North of Sand Hill Road

#### Segment 1 – Connection with Poinciana Parkway (CFX Project Number 538-235) to North of CR 532

The connection to Poinciana Parkway (SR 538) will be completed in two major construction phases having minor to no impact to the traffic along existing Poinciana Parkway (SR 538) to CR 532.

Phase 1 includes construction the new bridge over CR 532 and most of the interchange ramps (only leaving the connections to CR 532 to be completed later). It is anticipated that lane closures, diversions and/or detours will be needed along CR 532 during this phase.

Phase 2 includes construction of a left turn lane for the on-ramp from eastbound CR 532 to northbound Poinciana Parkway (SR 538) and right turn lane for the on-ramp from westbound CR 532 to northbound Poinciana Parkway (SR 538). These turn lanes and the connection to the interchange ramps should be completed after Poinciana Parkway (SR 538) is connected to I-4. Once the Poinciana Parkway (SR 538) traffic can access I-4, the existing ramps connecting to CR 532 can be removed and the new ramps can be open.

#### Segment 2 – From North of CR 532 to South of I-4/SR 429 Interchange

Construction of Poinciana Parkway (SR 538) from CR 532 to south of I-4/SR 429 Interchange can be completed in two phases. Phase 1 includes construction of noise walls. Phase 2 includes construction of Poinciana Parkway (SR 538) including the bridges.

#### Segment 3 – I-4

I-4 will require multiple phases and subphases to construct. Phase 1 include construction of noise walls. Phase 2 includes construction of the eastbound and the westbound I-4 general use lanes while maintaining traffic on the existing lanes. For Phase 3, I-4 traffic is shifted to the newly

constructed lanes. This phase includes construction of the eastbound and the westbound I-4 managed lanes.

#### Segment 4 – South of I-4/SR 429 Interchange to Sinclair Road

Phase 1 includes construction of noise walls. Phase 2 includes the removal of the existing southbound SR 429 to eastbound I-4 ramp bridge (Ramp C) while keeping the ramp operational. This phase can be achieved through the following steps:

- Construct temporary pavement from the existing southbound SR 429 to existing Ramp C bridge.
- Construct pavement for temporary ramp from southbound SR 429 to westbound I-4 general use lanes.
- Shift traffic from existing southbound SR 429 to I-4 onto temporary pavement and construct a portion of southbound SR 429, southbound SR 429 C-D system, ramp from southbound SR 429 to I-4 westbound general use lanes (Ramp A3), ramp from southbound SR 429 to I-4 eastbound general use lanes (Ramp C2), and ramp from westbound I-4 general use lanes to northbound SR 429 (Ramp D3).
- Once Ramp A3 and Ramp C2 are completed, the existing southbound SR 429 traffic is shifted to the newly constructed travel lanes and the existing Ramp C bridge is removed.

Phase 3 includes the removal of existing eastbound I-4 to northbound SR 429 ramp bridge (Ramp B) while keeping the ramp operational. This phase can be achieved through the following steps:

- Construct temporary pavement from eastbound I-4 general use lanes to the existing Ramp B bridge.
- Construct temporary pavement to divert northbound SR 429 traffic to existing southbound SR 429 lanes and back.
- Construct new ramp bridge from eastbound I-4 general use lanes to northbound SR 429 (Ramp B2) and northbound SR 429 C-D system. Once completed, westbound I-4 traffic to northbound SR 429 is shifted onto the new travel lanes and the existing Ramp B is removed.

Phase 4 includes construction of eastbound I-4 to southbound Poinciana Parkway (SR 538) ramp (Ramp B3) and westbound I-4 to southbound Poinciana Parkway (SR 538) ramp (Ramp D2) and the rest of southbound SR 429. Phase 5 includes construction of northbound SR 429, northbound Poinciana Parkway (SR 538) to westbound I-4 ramp (Ramp A1), southbound SR 429 to westbound I-4 managed lanes ramp (Ramp A2), eastbound I-4 managed lanes to northbound SR 429 (Ramp B1), and northbound Poinciana Parkway (SR 538) to eastbound I-4 general use lanes (Ramp C1).

The contractor could opt to complete these phases concurrently if it does not result in otherwise preventable disruptions and delays within the interchange system.



### Segment 5 – SR 429 From Sinclair Road to Sand Hill Road

From Sinclair Road to the north, SR 429 will be constructed with three major phases. Phase 1 includes construction activities inside of the existing travel lanes, while shifting traffic to the outside. Phase 2 includes construction to the outside of SR 429, while shifting traffic to the newly constructed inside pavement. Phase 3 shifts traffic to its final location.

#### *6.1.14 Special Features*

The Preferred Alternative will include noise barriers to address traffic noise impacts. A final determination for the need and location will be made during the design phase.

The Preferred Alternative will include mechanically stabilized earth (MSE) walls for most of the bridge approaches.

Landscaping will be included where appropriate at a level consistent with SR 429 and the proposed I-4 BtU. The *Poinciana Parkway PD&E Landscape Analysis and Opportunity Report*, available under separate cover, identifies potential landscape opportunities for the Preferred Alternative. Final landscaping plans will be developed during the Final Design phase for the mainline, ramps, toll sites, and stormwater ponds.

#### *6.1.15 Design Variations and Design Exceptions*

A design variation will be needed for Poinciana Parkway (SR 538) border width in the area around the FGT substation, southeast corner of the Poinciana Parkway (SR 538)/I-4/SR 429 interchange near Celebration Island Village, and the northeast corner of the Poinciana Parkway (SR 538)/I-4/SR 429 interchange near the Encore Resort at Reunion. The minimum border width is 94 feet. A reduction in border width is needed at these locations to avoid additional ROW.

In addition, a design variation will be needed for I-4 pavement cross slope. The standard cross slope is 0.03. An increase to 0.035 for the outside lane of I-4 is needed to address hydroplaning.

#### *6.1.16 Cost Estimates*

The total estimated cost for the Preferred Alternative is \$1,642.7 million. A breakdown of the costs associated with the Preferred Alternative is provided in Table 6-3. Construction cost estimates were developed through FDOT's Long Range Estimates (LRE) system, and a summary is provided in Appendix E.

Table 6-3: Cost Estimate for the Preferred Alternative

Project Element	Cost (in millions)
Construction Cost	\$1,273.56
Final Design Cost	\$127.36
CEI Cost	\$127.36
ROW Cost	\$86.58
Wetland Mitigation Cost	\$27.84

Final design and CEI costs are based on 10% of construction costs for each. The costs do not include the cost to relocate utilities. Determination of which utilities will require relocation will be determined with detailed survey information during the design phase of the project.

## 6.2 Summary of Environmental Impacts of the Preferred Alternative

### 6.2.1 Future Land Use

Most of the future land use designations in the study area are Conservation (Osceola County)/Preservation (Polk County) and Low-Density Residential (Osceola County)/Residential Low (Polk County). For Osceola County, Low-Density Residential is defined as three to eight dwelling units per acre. For Polk County, the Residential Low future land use is defined as one to four dwelling units per acre. The land use designation for the proposed ROW area would need to be changed to Transportation (or a transportation related land use category). The Preferred Alternative is not anticipated to change the land use designations for adjacent properties or lead to new development within existing conservation areas.

### 6.2.2 Section 4(f)

There are no potential Section 4(f) properties within the project area. Nearby recreational areas include golf courses that are privately owned and, therefore, not potential Section 4(f) resources. One historic structure (OS02770) was identified in the project area, and two additional structures (PO08197 and PO08109) are located adjacent to the project area. All three of those identified structures were determined to be ineligible for listing in the National Register of Historic Places (NRHP), so they are not considered potential Section 4(f) resources.

### 6.2.3 Cultural Resources

A *Cultural Resources Assessment Survey* (CRAS) was conducted within the project area and available under separate cover. Fifteen (15) archeological sites previously recorded within the project's area of potential effect (APE) were evaluated by the State Historic Preservation Officer (SHPO) and determined to be ineligible for the NHRP. Three (3) other sites were previously recorded but not evaluated by SHPO; however, they are likely to be ineligible. No new archaeological sites were identified within the APE as part of the survey effort for the project.

The historic resources field survey and research resulted in the identification of two newly identified historic structures (Sullivan House/1235 Sullivan Road/8OS3243, ca. 1941 and a corral/8OS3244, ca. 1941), one newly identified resource group (Sullivan Resource Group/8OS3245), and five newly identified historic bridges. Historical research has not revealed any significant associations with the Sullivan family or the resources at 1235 Sullivan Road (8OS3243, 8OS3244, and 8OS3245). Therefore, the historic resources are considered National Register ineligible individually and as a historic district. The five newly identified historic bridges are components of the Federal Interstate Highway System, which is exempt from Section 106 consideration under the 2005 Programmatic Agreement (PA), Section 106 Exemption Regarding Effects to the Interstate Highway System. The bridges are not individually eligible for the National Register and are not included on the list of exemptions to the PA for the State of Florida.

#### 6.2.4 Wetlands

Impacts to wetlands were evaluated in accordance with Executive Order (EO) 11990 and the PD&E Manual. The proposed project will not have significant short-term and long-term adverse impacts to wetlands. In accordance with EO 11990, all actions were taken to minimize the destruction, loss or degradation of wetlands, and to preserve and enhance the natural and beneficial values of wetlands. Nonetheless, there is no practicable alternative to construction impacts occurring in wetlands. Any unavoidable impacts to wetlands will be mitigated to achieve no net loss of wetland function.

Construction of the Preferred Alternative results in an estimated total of 133.27 acres of direct wetland impacts and 15.45 acres of surface waters. An additional 118.89 acres of wetland impacts are located within the 100-foot buffer and subject to secondary impacts. For the preferred pond sites, there are 24.55 acres of direct wetland impact and 28.06 acres of secondary impacts. Additionally, 10.81 acres of wetlands are under a conservation easement within the preferred pond sites.

Wetland impacts which will result from the construction of this project will be mitigated pursuant to Section 373.4137, F.S. Compensatory mitigation for this project will be completed through the use of mitigation banks and any other mitigation options that satisfy state and federal requirements. Additional information is provided in the *Natural Resources Evaluation* (NRE) Report provided under separate cover.

#### 6.2.5 Protected Species and Habitat

Thirty (30) species are listed by the US Fish and Wildlife Service (USFWS) as endangered or threatened. The project is located within USFWS Consultation Areas (CAs) of multiple federally protected species, including the sand and blue-tail mole skink (*Plestiodon reynoldsi*; *Plestiodon egregius lividus*), Florida grasshopper sparrow (*Ammodramus savannarum floridanus*), Florida scrub-jay (*Aphelocoma coerulescens*), crested caracara (*Caracara cheriway*), Everglade snail kite

(*Rostrhamus sociabilis plumbeus*), red-cockaded woodpecker (*Picooides borealis*) and within the core foraging area of three (3) wood stork (*Mycteria americana*) colonies.

In-house research and field reviews were conducted evaluating the habitat requirements for each species and the types of habitats present within the project study area. Twenty-one of the 30 species were determined to have no probability of occurrence due to a lack of suitable habitat and historical documentation within one mile of the project study area. Of the species with CAs overlapping the project study area, no suitable habitat for the crested caracara, Everglade snail kite, Florida grasshopper sparrow, and red-cockaded woodpecker was observed. The proposed project will have no effect on these species. An effect determination was made for each of these federal and state-listed species based on an analysis of the potential impacts of the proposed project on each species. A summary of the federally listed species and effect determinations is provided in Table 6-4.

Other species of concern include the bald eagle. This species has been federally de-listed by the USFWS. However, it remains federally protected under the Bald and Golden Eagle Protection Act (BGEPA) in accordance with the 16 United States Code 668 and the Migratory Bird Treaty Act of 1918. In addition, the FWC has implemented a bald eagle management plan (FWC 2008). Nests within Florida are monitored by the Florida Audubon Society which maintains a website of known bald eagle nest locations, and was last updated in 2021. According to this database, one (1) active bald eagle nest is located within one (1) mile of the project study area. Bald eagle nest OS231 is located approximately 0.6 miles (3,168 feet) northwest of I-4. The project study area is located outside of the nest's primary (330 feet) and secondary (660 feet) buffer zones. The nest was not monitored during the last nesting season, and its status is unknown. No bald eagle nests were observed within 660 feet of the project study area during field reviews. During design and permitting, FTE will survey the project area for eagle nests. If a nest is observed within 660 feet of the project limits, FTE will coordinate with the USFWS to secure all necessary permits.



Table 6-4: Federal Protected Species Effect Determinations

Project Effect Determination	Federal Listed Species	
	Species	Status*
"No effect"	<b>Flora</b>	
	Avon Park rabbit-bells ( <i>Crotalaria avonensis</i> )	FE
	Clasping warea ( <i>Warea amplexifolia</i> )	FE
	Florida bonamia ( <i>Bonamia grandiflora</i> )	FT
	Florida jointweed ( <i>Polygonella basiramia</i> )	FE
	Garrett's scrub balm ( <i>Dicerandra christamni</i> )	FE
	Perforate reindeer lichen ( <i>Cladonia perforate</i> )	FE
	Pygmy fringe tree ( <i>Chionanthus pygmaeus</i> )	FE
	Scrub buckwheat ( <i>Eriogonum longifolium</i> var. <i>gnaphalifolium</i> )	FT
	Scrub lupine ( <i>Lupinus aridorum</i> )	FE
	Scrub mint ( <i>Dicerandra frutescens</i> )	FE
	Scrub pigeon-wing ( <i>Clitoria fragrans</i> )	FT
	Short-leaved rosemary ( <i>Conradina brevifolia</i> )	FE
	Carter's warea ( <i>Warea carteri</i> )	FE
	Florida blazing star ( <i>Liatris ohlingerae</i> )	FE
	Highlands scrub hypericum ( <i>Hypericum cumulicola</i> )	FE
	Lewton's polygala ( <i>Polygala lewtonii</i> )	FE
	Papery nailwort ( <i>Paronychia chartacea</i> ssp. <i>chartacea</i> )	FT
	Scrub plum ( <i>Prunus geniculata</i> )	FE
	<b>Fauna</b>	
Florida grasshopper sparrow ( <i>Ammodramus savannarum floridanus</i> )	FE	
Crested caracara ( <i>Caracara cheriway</i> )	FT	
Everglade snail kite ( <i>Rostrhamus sociabilis plumbeus</i> )	FE	
Red-cockaded woodpecker ( <i>Picoides borealis</i> )	FE	
"May affect, but is not likely to adversely affect"	<b>Flora</b>	
	Britton's beargrass ( <i>Nolina brittoniana</i> )	FE
	Small's jointweed ( <i>Polygonella myriophylla</i> )	FE
	<b>Fauna</b>	
	American alligator ( <i>Alligator mississippiensis</i> )	FT
	Eastern indigo snake ( <i>Drymarchon couperi</i> )	FT
	Florida scrub-jay ( <i>Aphelocoma coerulescens</i> )	FT
Wood stork ( <i>Mycteria americana</i> )	FT	
"May affect, likely to adversely affect"	Blue-tailed mole skink ( <i>Plestiodon egregius lividus</i> )	FT
	Sand skink ( <i>Plestiodon reynoldsi</i> )	FT

\*FE – Federally endangered; FT – Federally threatened; SE – State endangered; ST – State threatened; C – Federal candidate; BGEPA – Bald and Golden Eagle Protection Act

Twenty-six (26) species are listed by FWC and FDACS as state endangered or threatened. In-house research and field reviews were conducted evaluating the habitat requirements for each species and the types of habitats present within the project study area. Eight of the 26 state listed species were determined to have no probability of occurrence due to a lack of suitable habitat within the project study area. Therefore, these species have been assigned a no effect anticipated

determination for this project. A summary of the state listed species and effect determinations is provided in Table 6-5.

Table 6-5: State Protected Species Effect Determinations

Project Effect Determination	State Listed Species	
"No effect"	Species	Status*
	Flora	
	Ashe's savory ( <i>Calamintha ashei</i> )	ST
	Chapman's sedge ( <i>Carex chapmannii</i> )	ST
	Florida beargrass ( <i>Nolina atopocarpa</i> )	ST
	Hartwrightia ( <i>Hartwrightia floridana</i> )	ST
	Incised groove-bur ( <i>Agrimonia incisa</i> )	ST
	Nodding pinweed ( <i>Lechea cernua</i> )	ST
	Piedmont jointgrass ( <i>Coelorachis tuberculosa</i> )	ST
	Fauna	
	Florida burrowing owl ( <i>Athene cunicularia floridana</i> )	ST
"No adverse effect anticipated"	Flora	
	Celestial lily ( <i>Nemastylis floridana</i> )	SE
	Cutthroat grass ( <i>Panicum abscissum</i> )	SE
	Florida spiny-pod ( <i>Matelea floridana</i> )	SE
	Florida willow ( <i>Salix floridana</i> )	SE
	Giant orchid ( <i>Pteroglossaspis ecristata</i> )	ST
	Many-flowered grass-pink ( <i>Calopogon multiflorus</i> )	ST
	Pine pinweed ( <i>Lechea divaricate</i> )	SE
	Pine-woods bluestem ( <i>Andropogon arctatus</i> )	ST
	Sand butterfly pea ( <i>Centrosema arenicola</i> )	SE
	Scrub bluestem ( <i>Andropogon arctatus</i> )	SE
	Star anise ( <i>Illicium parviflorum</i> )	SE
	Fauna	
	Gopher tortoise ( <i>Gopherus polyphemus</i> )	C/ST
	Florida pine snake ( <i>Pituophis melanoleucus mugitus</i> )	ST
	Little blue heron ( <i>Egretta caerulea</i> )	ST
	Tricolored heron ( <i>Egretta tricolor</i> )	ST
	Roseate spoonbill ( <i>Platalea ajaja</i> )	ST
	Florida sandhill crane ( <i>Antigone canadensis pratensis</i> )	ST
Southeastern American kestrel ( <i>Falco sparverius paulus</i> )	ST	

\*FE – Federally endangered; FT – Federally threatened; SE – State endangered; ST – State threatened; C – Federal candidate; BGEPA – Bald and Golden Eagle Protection Act

### *6.2.6 Essential Fish Habitat*

The proposed project is not located within or near any coastal resources and will not involve Essential Fish Habitat as none exists within the project study area. This was confirmed by the National Marine Fisheries Service (NMFS) in the ETDM comments.

### *6.2.7 Highway Traffic Noise*

A traffic noise study was performed in accordance with 23 CFR Part 772, Procedures for Abatement of Highway Traffic Noise and Construction Noise (July 13, 2010), and the FDOT's PD&E Manual and documented in a Noise Study Report (NSR) dated January 2023 and is located in the project file.

Noise levels at 579 residences and 26 special-use sites are predicted to approach or exceed the NAC for the design year 2050 Build Alternative. One hundred twenty-six residences and four special-use sites are expected to experience a substantial increase (15 dB(A)) in traffic noise compared to existing conditions.

Noise barriers were evaluated for all impacted sites identified in the noise modeling. The noise barrier analysis indicates that noise barriers could potentially provide reasonable and feasible noise abatement for 234 of the 579 impacted residences and provide a benefit to 44 non-impacted residences. The special use analysis determined that noise abatement was not feasible and reasonable for any of the 26 impacted special use sites; however, some special use locations will receive incidental benefits from noise barriers for the residential areas. The results of the noise barrier evaluations where noise abatement was determined to be potentially feasible and reasonable are summarized by noise sensitive area in Table 6-6 and Figure 6-18.

Table 6-6: Potentially Feasible and Reasonable Noise Barrier Evaluation Summary

Noise Sensitive Area	Number of Impacted Residences	Noise Barrier Approx. Begin Station	Noise Barrier Approx. End Station	Preliminary Noise Barrier Height (ft.)	Preliminary Noise Barrier Length (ft.) <sup>1</sup>	Preliminary Noise Barrier Location	Preliminary Noise Barrier Cost <sup>2</sup>	Number of Residences Potentially Benefited by a Noise Barrier <sup>3</sup>		Cost Per Benefited Residence
								Impacted	Total	
<b>NOISE BARRIERS NORTHBOUND SIDE OF SR 429</b>										
Encore West at Reunion, Reunion at 400 Apartments & Encore East at Reunion (CNE NB02 & WB03)	241	5363+05	5381+80	22	2,330	ROW	\$5,232,480	146	177	\$29,562
		338+00	875+00	22	2,058	Offset ROW				
		874+00	20+ (ramp)	22	3,540	ROW				
<b>NOISE BARRIERS EASTBOUND SIDE OF I-4</b>										
Reunion Village (CNE EB01)	31	5268+00	5286+00	22	1,804	ROW	\$1,190,640	31	38	\$31,333
<b>NOISE BARRIERS WESTBOUND SIDE OF I-4</b>										
Tuscana Condos (CNE WB01)	58	5262+55	5278+00	22	1,586	ROW	\$1,046,760	57	63	\$16,615

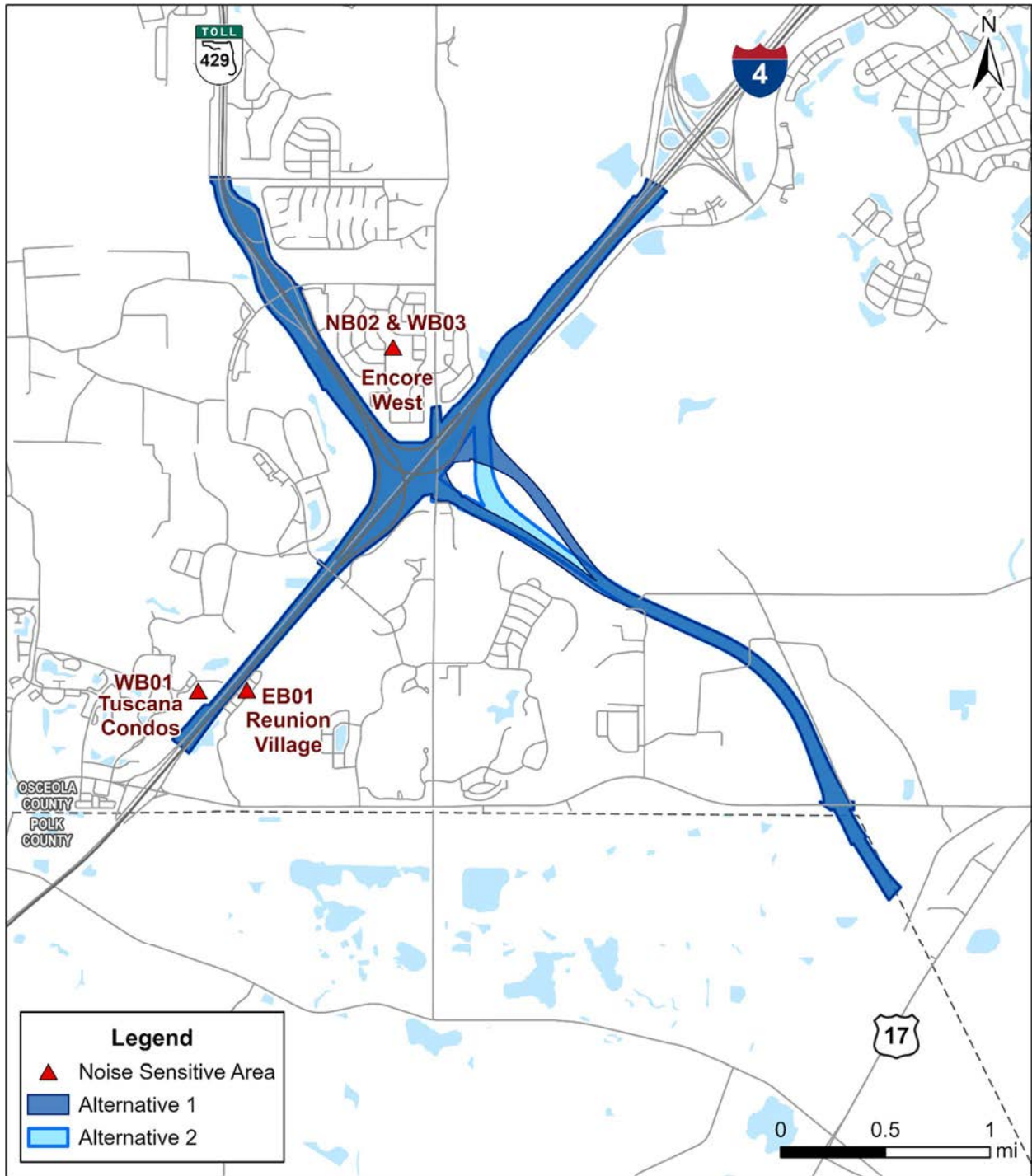
<sup>1</sup> Full height is for length indicated. The length for any required taper in height at a shoulder noise barrier termination would be in addition to the length indicated.

<sup>2</sup> Unit cost of \$30/ft<sup>2</sup> for all non-shoulder noise barriers.

<sup>3</sup> Total includes impacted/benefited residences and residences with a predicted noise level that does not approach or exceed 67 dBA but are incidentally benefited.



Figure 6-18: Potentially Feasible and Reasonable Noise Sensitive Sites



### 6.2.8 Contamination

Based on the contamination screening evaluation, a total of 24 sites were identified as summarized in Table 6-7. Of the 24 sites, none were rated as having a High potential for contamination impact and two sites were rated as having a Medium potential for contamination impact. The remaining 22 sites were rated as having a Low or No potential for contamination impact. Level II testing is recommended for all sites identified as High or Medium. Additional information and specific site locations are provided in the *Contamination Screening Evaluation Report* (CSER) provided under separate cover.

Table 6-7: Summary of Potential Contamination Sources

Site ID	Name	Location	Likely Contaminant	Risk Rating
1	Groves/Crops	Within and adjoining PPEC ROW and Within and adjoining I-4 ROW	Petroleum, Herbicides, Pesticides, and Arsenic	Low
2	Central Florida Pipeline (Stations 235 to 251, 1029 to 1030, 6200 to 6240, and 6290 to 6315) southern portion of project	Within proposed PPEC ROW and adjacent south side of I-4 east of PPEC	Petroleum	Low
3	Barn 1 (no address) SR 532	200 feet south of proposed PPEC ROW	Petroleum, Hazardous materials	No
4	Buried Debris and Barn 2 6802 Osceola Polk Line Road (Station 6200+00 to 6202+00)	Within proposed PPEC ROW	Solid Waste	Low
5	Residence 2 6812 Osceola Polk Line Road	Within proposed PPEC ROW	Petroleum, Hazardous Materials	Low
6	Sabal Trail Transmission Reunion 6781 Osceola Polk Line Road	Adjacent east of PPEC ROW	Hazardous Materials	Low
7	21 Palms RV Resort WWTP	Within and adjacent west of proposed	Domestic waste, hazardous materials	Low

## SECTION 6 – DESIGN FEATURES OF THE PREFERRED ALTERNATIVE

Site ID	Name	Location	Likely Contaminant	Risk Rating
	6781 Osceola Polk Line Road	PPEC ROW		
8	1225 Sullivan Road	Within proposed PPEC ROW	Petroleum, Hazardous Materials	Medium
9	1235 Sullivan Road	Adjacent southwest of proposed PPEC ROW	Petroleum, Hazardous Materials	Low
10	Golf at Reunion Resort (Formerly Heidrich & Sons/Magnolia Creek East) 7593 Gathering Drive	Adjacent west of Proposed PPEC ROW	Pesticides, Herbicides, Arsenic, Petroleum	Low
11	FGT Davenport Compressor Station 31 727 S. Old Lake Wilson Road	Adjacent south of I-4, east of PPEC ROW, and west of the PPEC entrance ramp to I-4	Petroleum, hazardous materials	Low
12	East Green Swamp Station 456 S. Old Lake Wilson Road	Adjacent south of I-4, east of PPEC ROW, and west of the PPEC entrance ramp to I-4	Hazardous materials	Low
13	Former RV Park S. Old Lake Wilson Road	Adjacent south of I-4, east of PPEC ROW, and west of the PPEC entrance ramp to I-4	Hazardous materials	Low
14	SBA Cell Tower S. Old Lake Wilson Road	Adjacent south of I-4, east of PPEC ROW, and west of the PPEC entrance ramp to I-4	Petroleum	Low
15	Lift Station 14851 Coastal Court	420 feet east of PPEC ROW	Hazardous Waste	No
16	Ethylene Dibromide (EDB)	Within SR 429/I-4 interchange ROW	EDB	Low

## SECTION 6 – DESIGN FEATURES OF THE PREFERRED ALTERNATIVE

Site ID	Name	Location	Likely Contaminant	Risk Rating
	Groundwater Contamination Zone #49263268 No address	Southwest of Station 6335+00 to Station 6350+00		
17	TECO Osceola Gate Station 710 N. Lake Wilson Road	Adjoining north	Hazardous Materials	Low
18	Mystic Dunes Resort & Golf Club 7600 Mystic Dunes Lane	Adjacent east of SR 429 ROW	Pesticides, Herbicides, Arsenic, Petroleum	Low
19	Sand Hill WWTP 3211 Sand Hill Road Kissimmee City-Sand Hill WWTP 8000 Sand Hill Road KISSIMMEE City - WWTP 300 Sand Hill Road 8200 Sand Hill Road	1,900 feet north of project limit	Petroleum, Hazardous Materials	Low
20	Osceola Substation 2360 World Drive (Interior Street)	Adjacent north of I-4 ROW	MODEF, PCBs, LEAD	Low
21	Lake Wilson Substation 1001 N. Lake Wilson Road	1,200 feet north of I-4 ROW	MODEF, PCBs, LEAD	No
22	Best Diversified, Inc./ P&D Landfill 945 S. Old Lake Wilson Road	250 feet north of Proposed I-4 ROW	Ammonia-N, Total Dissolved Solids (TDS), Petroleum	Medium
23	Reunion West Golf Course 775 Golden Bear Drive	Adjacent north of I-4 ROW	Pesticides, Herbicides, Arsenic, Petroleum	Low
24	Planted Pine Trees	Within and adjoining PPEC ROW	Herbicides, Pesticides, and Arsenic	Low



## APPENDIX A

# Value Engineering Resolution Memorandum

## VALUE ENGINEERING RESOLUTION MEMORANDUM

**Date:** November 1, 2022

**To:** Jennifer Stults, AICP, Interim Director of Transportation Development

**From:** Michael Leo, PE, Project Manager (HNTB)

**Subject:** Value Engineering (VE) Resolution Memorandum  
FPID # 446581-1  
Poinciana Parkway Extension Connector Project Development and Environment  
(PD&E) Study from CR 532 to North of I-4/SR 429 Interchange in Osceola County

A Cost Risk and Value Engineering (CRAVE) study was conducted from June 14-16, 2022, and June 28-July 1, 2022. The PD&E team presented an overview of the project and results of the February 23 and 24, 2022 Public Information Meetings to the CRAVE team on June 14, 2022 and were available throughout the week for questions. The CRAVE team developed 14 Value Engineering (VE) recommendations and presented their findings to Florida's Turnpike Enterprise (FTE) Management and the project team on July 1, 2022. A presentation was held on September 15, 2022, for senior FTE Management and staff to review the FTE Team's proposed responses and recommendations. Subsequent coordination with the VE team was needed to address some of the questions that were received at the September 15, 2022, presentation. A follow up presentation was held on October 7, 2022, to provide FTE management with additional information on the VE recommendations. FTE Management agreed to proceed with the VE recommendations as described below.

The following section describes the analysis and findings conducted by the PD&E team in reviewing each of the 14 VE recommendations presented by the CRAVE Team. VE resolutions are identified as 'Yes' for accepted, 'No' for not recommended for implementation, or 'Defer' to advance to the Design Phase for further investigation and/or refinement.

### **1. VE Recommendation 2: Minimize structures outside of floodway**

**VE Recommendation:** The VE recommends reducing the length and height of low-level bridges through wetlands (outside of floodway) and use embankment.

Possible savings = \$46.34 million

**Response and Recommendation:** The PD&E team evaluated the amount of bridge length that can be minimized over the floodway and approximately 3,000 LF of bridge length can be reduced by not bridging over the entire 100-yr storm floodplain, equaling a savings of \$16.2 million.

**Yes/Defer to Design - This recommendation is accepted. The Preferred Alternative will reduce the bridge lengths over the floodway as much as possible, based on available data. It**

is recommended that this bridge reduction evaluation continues through the design phase. Saving is approximately \$16.2 million.

**2. VE Recommendation 3: Reconfigure Poinciana Parkway at Sinclair Road**

**VE Recommendation:** The VE recommends reconfiguring SR 429/Poinciana Parkway geometry to fit under Sinclair Road (PPE project) by moving the gores south on Poinciana Parkway and reducing the footprint at Sinclair Road.

Possible savings = \$7.430 million

**Response and Recommendation:** The PD&E team evaluated moving the gore location on Poinciana Parkway to the south of Sinclair Road bridge. With shifting the gore location and reducing the median width between the mainlines, the preferred alternative can fit underneath the existing Sinclair Road bridge.

**Yes - This recommendation is accepted. The Preferred Alternative will be reconfigured to fit geometrically under Sinclair Road. Saving is approximately \$7.43 million.**

**3. VE Recommendation 4: Maximize Drainage Area**

**VE Recommendation:** The VE Team recommends maximizing the capacity of infield ponds by regrading and lowering the pond bottom.

Possible savings = \$5.475 million

**Response and Recommendation:** SR 429 stormwater management was permitted for 6 lanes. The Preferred Alternative is maximizing the existing drainage areas by modifying bottom elevations and regrading existing ponds to accommodate 8 lanes.

**Defer to Design – This recommendation should be deferred to design for further considerations.**

**4. VE Recommendation 5: Shift Poinciana Parkway to Minimize Utility Conflicts**

**VE Recommendation:** The VE recommends two options for reducing the utility impacts along Poinciana Parkway south of I-4.

- Shift Poinciana Parkway alignment to the east
- Shift Poinciana Parkway alignment to the west

Possible savings = \$20 million with an eastern shift

Possible savings = \$84 million with a western shift.

**Response and Recommendation:** Shifting the alignment to the east creates a very curvilinear alignment, which impacts conservation areas and the Celebration Island Development.

Shifting the alignment to the west results in avoiding impacts to four out of 34 Duke Transmission poles but places the facility approximately 200 ft closer to the Reunion Development, which could result in strong community opposition.

**No - This recommendation should not be considered for implementation.**

**5. VE Recommendation 6: Reconfigure Ramp D1**

**VE Recommendation:** The VE Team recommends reconfiguring Ramp D1 so that alignment is between the WB Express Lanes and the WB General Purpose Lanes.

Possible savings = \$13.158 million

**Response and Recommendation:** The PD&E team evaluated this location and determined with the realignment of Ramp D1 and I-4 WB that about 1 Acre of R/W will be saved. However, an additional 2,000 LF of bridge will be needed to achieve this realignment.

**No - This recommendation should not be considered for implementation.**

**6. VE Recommendation 8: Simplify Poinciana Parkway/I-4 Movements**

**VE Recommendation:** The VE Team recommends realigning SB Poinciana Parkway to WB I-4 to reduce structures (Ramp A3). The VE Team also recommends combining and simplifying SR 429/I-4 ramp gore movements on the west side of the interchange (Ramp A1 and A3 and B2 and B3).

Possible savings = \$33.895 million

**Response and Recommendation:** Combining Ramp A1 and Ramp A3 - The PD&E team evaluated this location and determined Ramp A1 needs to go over Ramp A2 as it does not have sufficient distance to reach ground level. Raising Ramp A2 will increase bridge construction for the Express Lanes. Placing Ramp A1 over Ramp A2 and then combining with Ramp A3 requires approximately 1,500' to connect to ground prior to Tradition Blvd bridge. This configuration requires additional R/W beyond the baseline and bridge length.

Combining Ramp B2 and Ramp B3 - The PD&E team evaluated this location, and the configuration has additional R/W impacts along with the impacts to Reunion's entrance and parking lot.

**No - This recommendation should not be considered for implementation.**

**7. VE Recommendation 9: Harvest Stormwater for Golf Course irrigation**

**VE Recommendation:** The VE Team recommends partnering with nearby golf courses to harvest runoff from Poinciana Parkway Extension for irrigation purposes.

Possible savings = \$3.111 million

**Response and Recommendation:** The PD&E team understands the importance of working with adjacent property owners to obtain a win-win solution for stormwater management.

Traditionally, golf courses provide a great opportunity for stormwater management given their needs for large amounts of water. However, this project presents several design challenges that must be overcome to accomplish this task:

- The existing golf course varies in elevation from 91-ft to 101-ft. The existing ground at the proposed alignment is 83-ft. A pump will be required to get water to the golf course.
- Attenuation and treatment requirements are still required, which do not lessen the proposed pond size by a substantial amount.

**Defer to Design – This recommendation should be deferred to design for further**

considerations.

**8. VE Recommendation 10: Bridge Celebration Boulevard over Poinciana Parkway**

**VE Recommendation:** The VE Team recommends spanning Celebration Boulevard over Poinciana Parkway Extension.

Possible savings = \$3.251 million

**Response and Recommendation:** The PD&E team agrees with the cost benefits associated with placing Celebration Boulevard over Poinciana Parkway. Further agency coordination between Turnpike and Osceola County will need to be done.

**Yes – Pending Agency Coordination.**

**9. VE Recommendation 11: Resequencing the Construction Phasing**

**VE Recommendation:** The VE Team recommends resequencing the construction phasing to construct I-4 General Purpose (GP) lanes/General Use Lanes (GUL) first to accommodate the SR 429/Poinciana Parkway connection.

Possible savings = Not determined

**Response and Recommendation:** The PD&E team will continue coordination with D5 to determine if I-4 BtU improvements should be included as a 1<sup>st</sup> stage of construction, followed by Poinciana Parkway Extension Connector, and then the interchange.

**Yes - This recommendation is accepted, pending agency coordination.**

**10. VE Recommendation 12: Shift I-4 Eastbound alignment to the south**

**VE Recommendation:** The VE Team recommends shifting the EB I-4 GUL lanes to the south to remove the EB elevated express lanes.

Possible savings = \$90.498 million

**Response and Recommendation:** PD&E team agrees with the benefits of shifting the EB I-4 GUL lanes to the south to lower the EB I-4 EL to the ground and not have it elevated over the GUL. This recommendation will reduce bridge construction by about 5,500 LF.

**Yes - This recommendation should be considered for implementation. Saving is approximately \$90.498 million.**

**11. VE Recommendation 13: Optimize MSE Walls Heights**

**VE Recommendation:** The VE Team recommends optimizing MSE wall heights (maximum 40ft) along PPE and convert bridges to walls, where feasible.

Possible savings = \$39.435 million

**Response and Recommendation:** The PD&E team agrees with the benefits of maximizing retaining wall heights (40 ft) as much as possible and reducing bridge lengths.

**Yes/Defer to Design – This recommendation should be considered for implementation. The Preferred Alternative will maximize the MSE walls as much as possible. Saving is approximately \$19.7 million.**



**12. VE Recommendation 14: Reconfigure Ramp C2 Flyover**

**VE Recommendation:** The VE Team recommends dropping C2 flyover ramp to ground level before Ramp D2 and Ramp C3.

Possible savings = \$15.017 million

**Response and Recommendation:** The PD&E team evaluated this recommendation and determined lowering the profile below Ramp C3 will impact the vertical clearance over mainline SR 429. SR 429 can't be lowered due to Ramp B2 (which is providing minimum vertical clearance over I-4). The Design team also evaluated this recommendation which raises the profile of Ramp C3 to allow Ramp C2 to not impact the mainline profiles, but this will have an impact on Ramp D2's and the EB I-4 EL's bridge to become longer with the increase of height of Ramp C3.

**No - This recommendation should not be considered for implementation.**

**13. VE Recommendation 15: Move Poinciana Parkway through movements to 4<sup>th</sup> level**

**VE Recommendation:** The VE Team gave two options for this recommendation. The first option is to max out the profile grades of the mainline and ramps. While the second option is moving Poinciana Parkway (SR 429) through-movements to the 4<sup>th</sup> level and adjust the ramp profiles so compatible movements are located at the same level while keeping the two existing ramps (Ramp B2 and Ramp C2).

Possible savings = \$46.562 million with option 1

Possible savings = \$143.908 million with option 2

**Response and Recommendation:** The PD&E team evaluated both options. With the first option, the PD&E team agrees with the benefits of maximizing the grades of the mainline and the ramps to reduce bridge cost. The Design team evaluated the saving of the existing flyover bridges and placing the mainline movements and that will cause the mainline bridges to become longer overall. The VE Team also recommended that Ramp A1 be relocated and combined with the movements with Ramp C1 with the SR 429 moving to the fourth level. With this relocation, Ramp A1's bridge will become longer overall since it cannot go over Old Lake Wilson Road as a Level 3 bridge and get to ground before reaching the existing Ramp B bridge.

**Yes – The first recommendation should be considered for implementation. The Preferred Alternative will maximize the grades as much as possible. Saving is approximately \$16.17 million.**

**No – The second recommendation should not be considered for implementation.**

## APPENDIX B

### Typical Sections for the Preferred Alternative

STATE OF FLORIDA  
DEPARTMENT OF TRANSPORTATION  
TYPICAL SECTION PACKAGE

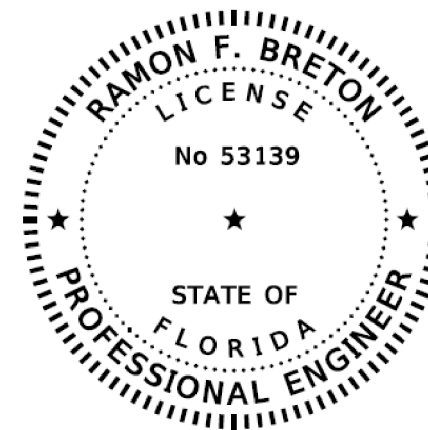
FINANCIAL PROJECT ID 446581-1-22-01

OSCEOLA & POLK COUNTIES

STATE ROAD NO. 429

POINCIANA PARKWAY EXTENSION CONNECTOR PD&E STUDY  
FROM CR532 TO NORTH OF I-4/SR429 INTERCHANGE

APPROVED BY:



THE ABOVE NAMED PROFESSIONAL ENGINEER SHALL BE RESPONSIBLE FOR THE FOLLOWING SHEETS IN ACCORDANCE WITH RULE 61G15-23.004, F.A.C.

TYPICAL SECTION PACKAGE

SHEET NO.	SHEET DESCRIPTION
1	KEY SHEET
2 - 10	TYPICAL SECTION NO. 1a - 6
11 - 26	TYPICAL SECTION NO. 7 - 23 (BRIDGE STRUCTURES)

**TYPICAL SECTION CONCURRENCE**

TURNPIKE DISTRICT STRUCTURES  
DESIGN ENGINEER

MOATAZ "MO" HASSAN, P.E.  
TURNPIKE DISTRICT DESIGN ENGINEER

RUSS SNYDER, P.E.  
CONCURRING WITH:  
TYPICAL SECTION ELEMENTS

N/A  
FHWA TRANSPORTATION ENGINEER

**DESIGN SPEED AND POSTED  
SPEED CONCURRENCE :**

JOHN R. EASTERLING, IV, P.E., PTOE  
TURNPIKE DISTRICT TRAFFIC OPERATIONS  
ENGINEER

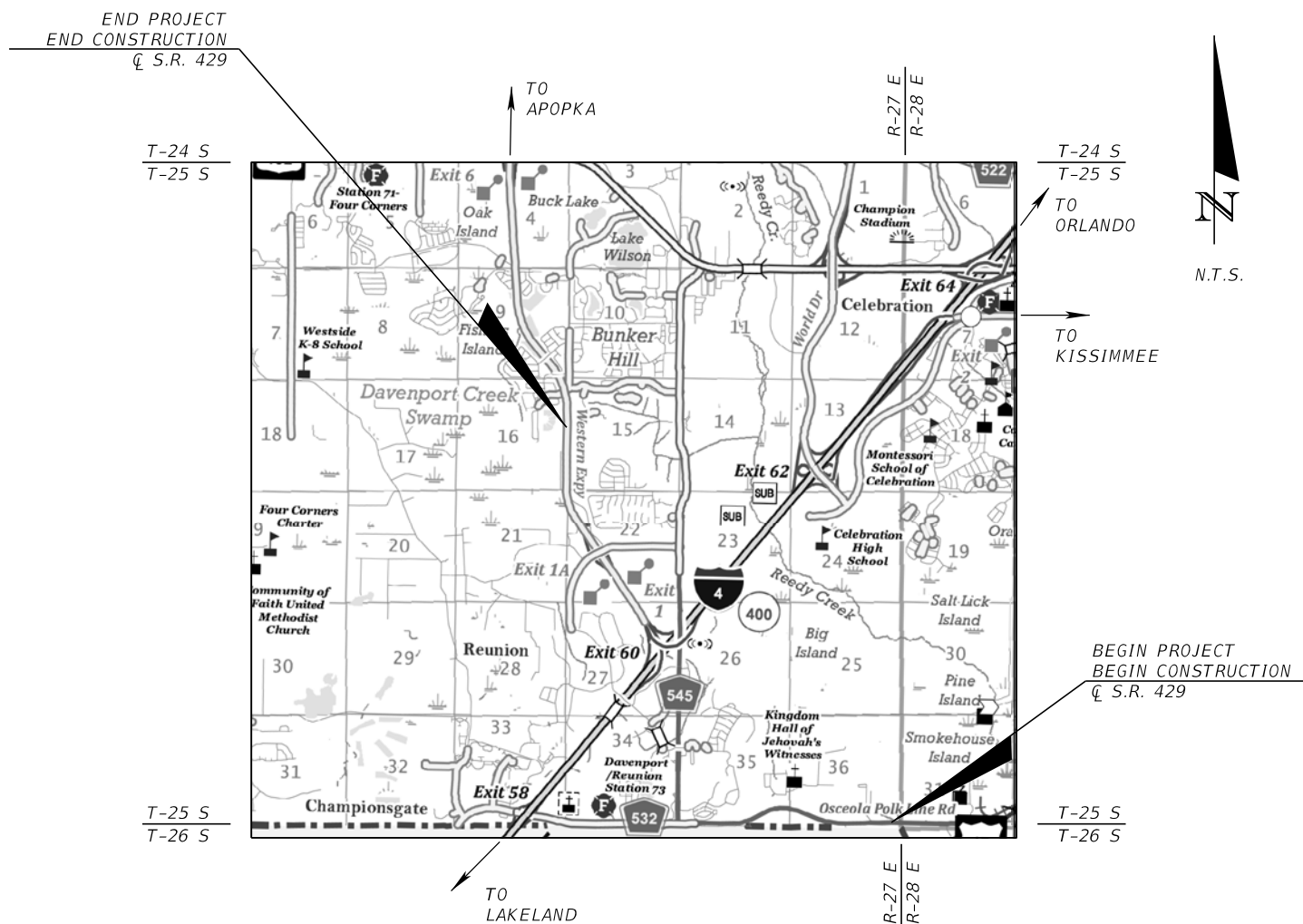
MOATAZ "MO" HASSAN, P.E.  
TURNPIKE DISTRICT DESIGN ENGINEER

**CONTEXT CLASSIFICATION  
CONCURRENCE :**

JENNIFER STULTS, AICP  
TURNPIKE DISTRICT INTERMODAL SYSTEMS  
DEVELOPMENT MANAGER

SHEET  
NO.

1



**PROJECT CONTROLS**

**CONTEXT CLASSIFICATION**

- ( ) C1 : NATURAL                      ( ) C3C : SUBURBAN COMM.
- ( ) C2 : RURAL                        ( ) C4 : URBAN GENERAL
- ( ) C2T : RURAL TOWN                ( ) C5 : URBAN CENTER
- ( ) C3R : SUBURBAN RES.            ( ) C6 : URBAN CORE
- (X) N/A : L.A. FACILITY

**FUNCTIONAL CLASSIFICATION**

- ( ) INTERSTATE                        ( ) MAJOR COLLECTOR
- (X) FREEWAY/EXPWY.                ( ) MINOR COLLECTOR
- ( ) PRINCIPAL ARTERIAL            ( ) LOCAL
- ( ) MINOR ARTERIAL

**HIGHWAY SYSTEM**

- (X) NATIONAL HIGHWAY SYSTEM
- (X) STRATEGIC INTERMODAL SYSTEM
- (X) STATE HIGHWAY SYSTEM
- ( ) OFF-STATE HIGHWAY SYSTEM

**ACCESS CLASSIFICATION**

- (X) 1 - FREEWAY
- ( ) 2 - RESTRICTIVE w/Service Roads
- ( ) 3 - RESTRICTIVE w/660 ft. Connection Spacing
- ( ) 4 - NON-RESTRICTIVE w/2640 ft. Signal Spacing
- ( ) 5 - RESTRICTIVE w/440 ft. Connection Spacing
- ( ) 6 - NON-RESTRICTIVE w/1320 ft. Signal Spacing
- ( ) 7 - BOTH MEDIAN TYPES

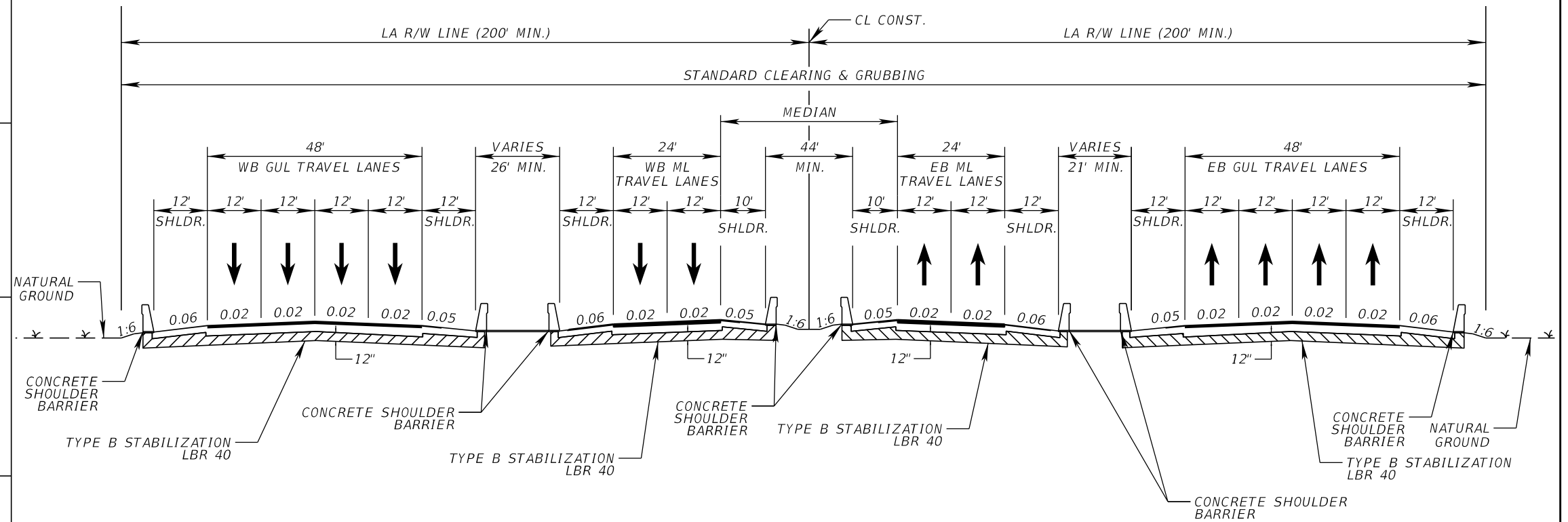
**CRITERIA**

- (X) NEW CONSTRUCTION / RECONSTRUCTION
- ( ) RESURFACING (LA FACILITIES)
- ( ) RRR (ARTERIALS & COLLECTORS)

**POTENTIAL EXCEPTIONS AND VARIATIONS RELATED TO TYPICAL SECTION:**

BORDER WDTN DESIGN VARIATION MEMO

**TYPICAL SECTION No. 1a**



**PROPOSED 8-LANE GENERAL USE LANES (GUL)  
WITH 4-LANE MANAGED LANES (ML)  
INTERSTATE 4 (BARRIER SEPARATED)**

**TRAFFIC DATA**

CURRENT YEAR = 2020 AADT = 72,100 (EB) 76,000 (WB)  
 ESTIMATED OPENING YEAR = 2030 AADT = 84,600 (EB) 84,600 (WB)  
 ESTIMATED DESIGN YEAR = 2050 AADT = 80,700 (EB) 80,700 (WB)  
 K = 8.0% D = 56.0% T = 13.3% (24 HOUR)  
 DESIGN HOUR T = 7.0%  
 DESIGN SPEED = 70 MPH

FINANCIAL PROJECT ID	SHEET NO.
446581-1-22-01	2

THE OFFICIAL RECORD OF THIS SHEET IS THE ELECTRONIC FILE DIGITALLY SIGNED AND SEALED UNDER RULE 61G15-23.004, F.A.C.

**PROJECT CONTROLS**

**CONTEXT CLASSIFICATION**

- ( ) C1 : NATURAL            ( ) C3C : SUBURBAN COMM.
- ( ) C2 : RURAL            ( ) C4 : URBAN GENERAL
- ( ) C2T : RURAL TOWN    ( ) C5 : URBAN CENTER
- ( ) C3R : SUBURBAN RES. ( ) C6 : URBAN CORE
- (X) N/A : L.A. FACILITY

**FUNCTIONAL CLASSIFICATION**

- ( ) INTERSTATE            ( ) MAJOR COLLECTOR
- (X) FREEWAY/EXPWY.    ( ) MINOR COLLECTOR
- ( ) PRINCIPAL ARTERIAL   ( ) LOCAL
- ( ) MINOR ARTERIAL

**HIGHWAY SYSTEM**

- (X) NATIONAL HIGHWAY SYSTEM
- (X) STRATEGIC INTERMODAL SYSTEM
- (X) STATE HIGHWAY SYSTEM
- ( ) OFF-STATE HIGHWAY SYSTEM

**ACCESS CLASSIFICATION**

- (X) 1 - FREEWAY
- ( ) 2 - RESTRICTIVE w/Service Roads
- ( ) 3 - RESTRICTIVE w/660 ft. Connection Spacing
- ( ) 4 - NON-RESTRICTIVE w/2640 ft. Signal Spacing
- ( ) 5 - RESTRICTIVE w/440 ft. Connection Spacing
- ( ) 6 - NON-RESTRICTIVE w/1320 ft. Signal Spacing
- ( ) 7 - BOTH MEDIAN TYPES

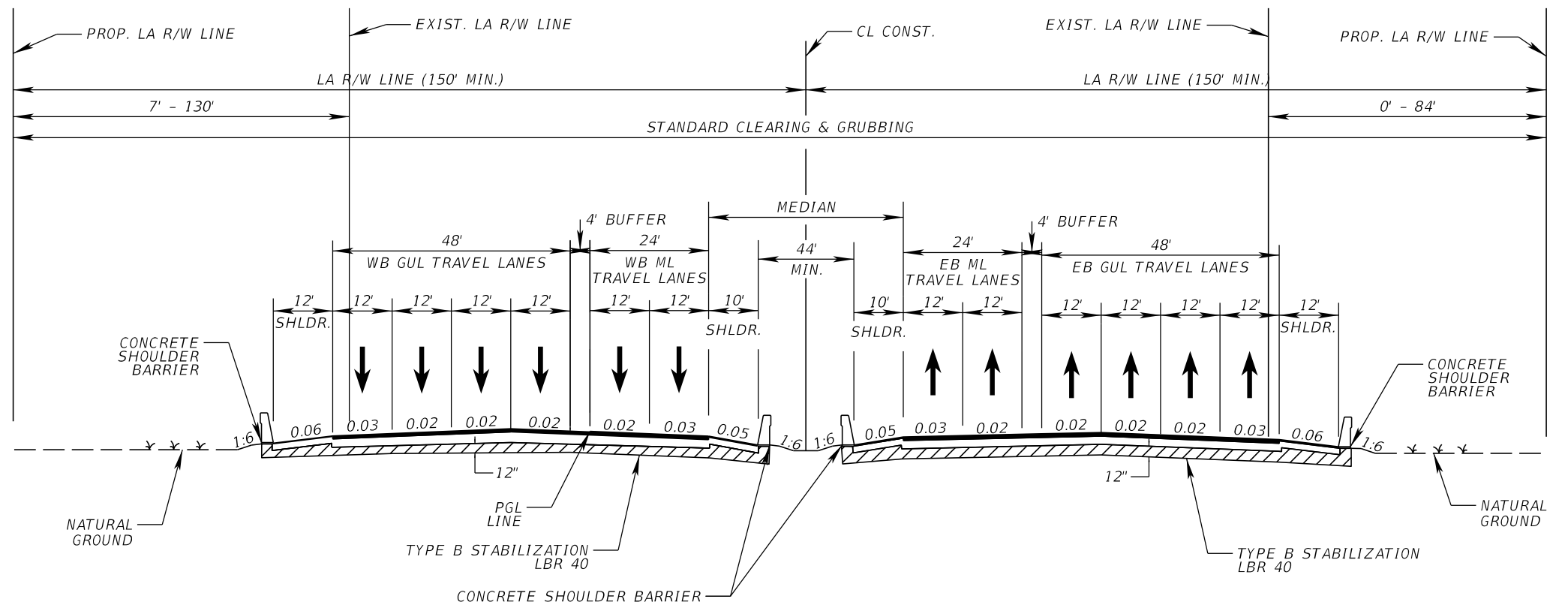
**CRITERIA**

- (X) NEW CONSTRUCTION / RECONSTRUCTION
- ( ) RESURFACING (LA FACILITIES)
- ( ) RRR (ARTERIALS & COLLECTORS)

**POTENTIAL EXCEPTIONS AND VARIATIONS RELATED TO TYPICAL SECTION:**

CROSS SLOPE DESIGN VARIATION  
BORDER WIDTH DESIGN VARIATION MEMO

**TYPICAL SECTION No. 1b**



**PROPOSED 8-LANE GENERAL USE LANES (GUL)  
WITH 4-LANE MANAGED LANES (ML)  
INTERSTATE 4 (BUFFER SEPARATED)**

\* CROSS SLOPE IS ADJUSTED FOR HYDROPLANING CONDITIONS

**TRAFFIC DATA**

CURRENT YEAR = 2020 AADT = 72,100 (EB) 76,000 (WB)  
ESTIMATED OPENING YEAR = 2030 AADT = 84,600 (EB) 84,600 (WB)  
ESTIMATED DESIGN YEAR = 2050 AADT = 80,700 (EB) 80,700 (WB)  
K = 8.0% D = 56.0% T = 13.3% (24 HOUR)  
DESIGN HOUR T = 7.0%  
DESIGN SPEED = 70 MPH

FINANCIAL PROJECT ID	SHEET NO.
446581-1-22-01	3

THE OFFICIAL RECORD OF THIS SHEET IS THE ELECTRONIC FILE DIGITALLY SIGNED AND SEALED UNDER RULE 61G15-23.004, F.A.C.



**PROJECT CONTROLS**

**CONTEXT CLASSIFICATION**

- ( ) C1 : NATURAL            ( ) C3C : SUBURBAN COMM.
- ( ) C2 : RURAL            ( ) C4 : URBAN GENERAL
- ( ) C2T : RURAL TOWN    ( ) C5 : URBAN CENTER
- ( ) C3R : SUBURBAN RES. ( ) C6 : URBAN CORE
- (X) N/A : L.A. FACILITY

**FUNCTIONAL CLASSIFICATION**

- ( ) INTERSTATE            ( ) MAJOR COLLECTOR
- (X) FREEWAY/EXPWY.    ( ) MINOR COLLECTOR
- ( ) PRINCIPAL ARTERIAL ( ) LOCAL
- ( ) MINOR ARTERIAL

**HIGHWAY SYSTEM**

- (X) NATIONAL HIGHWAY SYSTEM
- (X) STRATEGIC INTERMODAL SYSTEM
- (X) STATE HIGHWAY SYSTEM
- ( ) OFF-STATE HIGHWAY SYSTEM

**ACCESS CLASSIFICATION**

- (X) 1 - FREEWAY
- ( ) 2 - RESTRICTIVE w/Service Roads
- ( ) 3 - RESTRICTIVE w/660 ft. Connection Spacing
- ( ) 4 - NON-RESTRICTIVE w/2640 ft. Signal Spacing
- ( ) 5 - RESTRICTIVE w/440 ft. Connection Spacing
- ( ) 6 - NON-RESTRICTIVE w/1320 ft. Signal Spacing
- ( ) 7 - BOTH MEDIAN TYPES

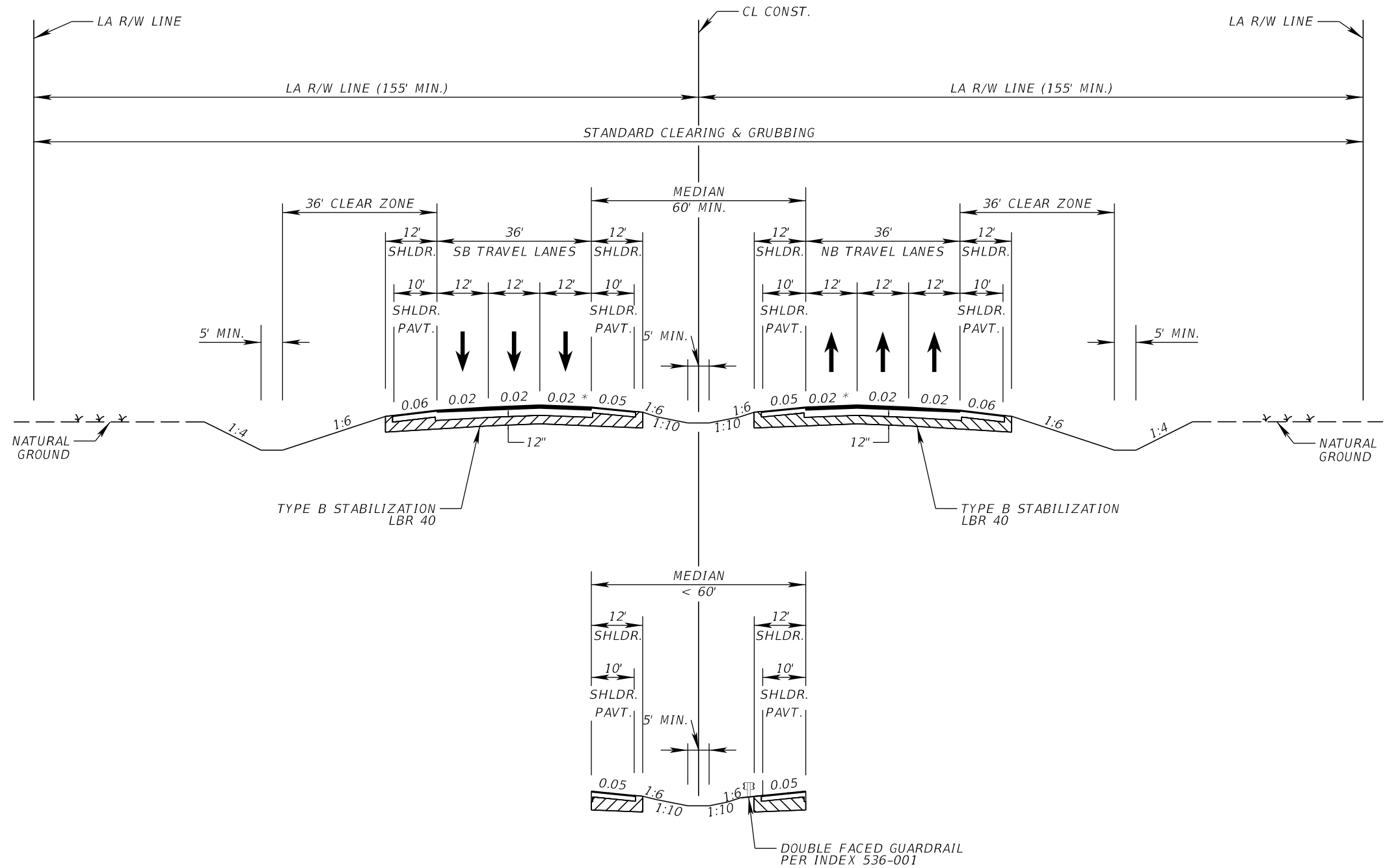
**CRITERIA**

- (X) NEW CONSTRUCTION / RECONSTRUCTION
- ( ) RESURFACING (LA FACILITIES)
- ( ) RRR (ARTERIALS & COLLECTORS)

**POTENTIAL EXCEPTIONS AND VARIATIONS RELATED TO TYPICAL SECTION:**

BORDER WIDTH DESIGN VARIATION MEMO

**TYPICAL SECTION No. 2**



PROPOSED 6-LANE TYPICAL SECTION  
POINCIANA PARKWAY EXTENSION (SR 538)  
FROM SR 532 to I-4

\* CROSS SLOPE SET UP FOR FUTURE WIDENING

**TRAFFIC DATA**

CURRENT YEAR = 2020 AADT = N/A  
 ESTIMATED OPENING YEAR = 2030 AADT = 12,000 (NB) 12,000 (SB)  
 ESTIMATED DESIGN YEAR = 2050 AADT = 23,000 (NB) 23,000 (SB)  
 K = 11.0% D = 60.0% T = 12.8% (24 HOUR)  
 DESIGN HOUR T = 7.0%  
 DESIGN SPEED = 70 MPH

FINANCIAL PROJECT ID	SHEET NO.
446581-1-22-01	4

THE OFFICIAL RECORD OF THIS SHEET IS THE ELECTRONIC FILE DIGITALLY SIGNED AND SEALED UNDER RULE 61G15-23.004, F.A.C.

**PROJECT CONTROLS**

**CONTEXT CLASSIFICATION**

- ( ) C1 : NATURAL            ( ) C3C : SUBURBAN COMM.
- ( ) C2 : RURAL            ( ) C4 : URBAN GENERAL
- ( ) C2T : RURAL TOWN    ( ) C5 : URBAN CENTER
- ( ) C3R : SUBURBAN RES. ( ) C6 : URBAN CORE
- (X) N/A : L.A. FACILITY

**FUNCTIONAL CLASSIFICATION**

- ( ) INTERSTATE            ( ) MAJOR COLLECTOR
- (X) FREEWAY/EXPWY.    ( ) MINOR COLLECTOR
- ( ) PRINCIPAL ARTERIAL ( ) LOCAL
- ( ) MINOR ARTERIAL

**HIGHWAY SYSTEM**

- (X) NATIONAL HIGHWAY SYSTEM
- (X) STRATEGIC INTERMODAL SYSTEM
- (X) STATE HIGHWAY SYSTEM
- ( ) OFF-STATE HIGHWAY SYSTEM

**ACCESS CLASSIFICATION**

- (X) 1 - FREEWAY
- ( ) 2 - RESTRICTIVE w/Service Roads
- ( ) 3 - RESTRICTIVE w/660 ft. Connection Spacing
- ( ) 4 - NON-RESTRICTIVE w/2640 ft. Signal Spacing
- ( ) 5 - RESTRICTIVE w/440 ft. Connection Spacing
- ( ) 6 - NON-RESTRICTIVE w/1320 ft. Signal Spacing
- ( ) 7 - BOTH MEDIAN TYPES

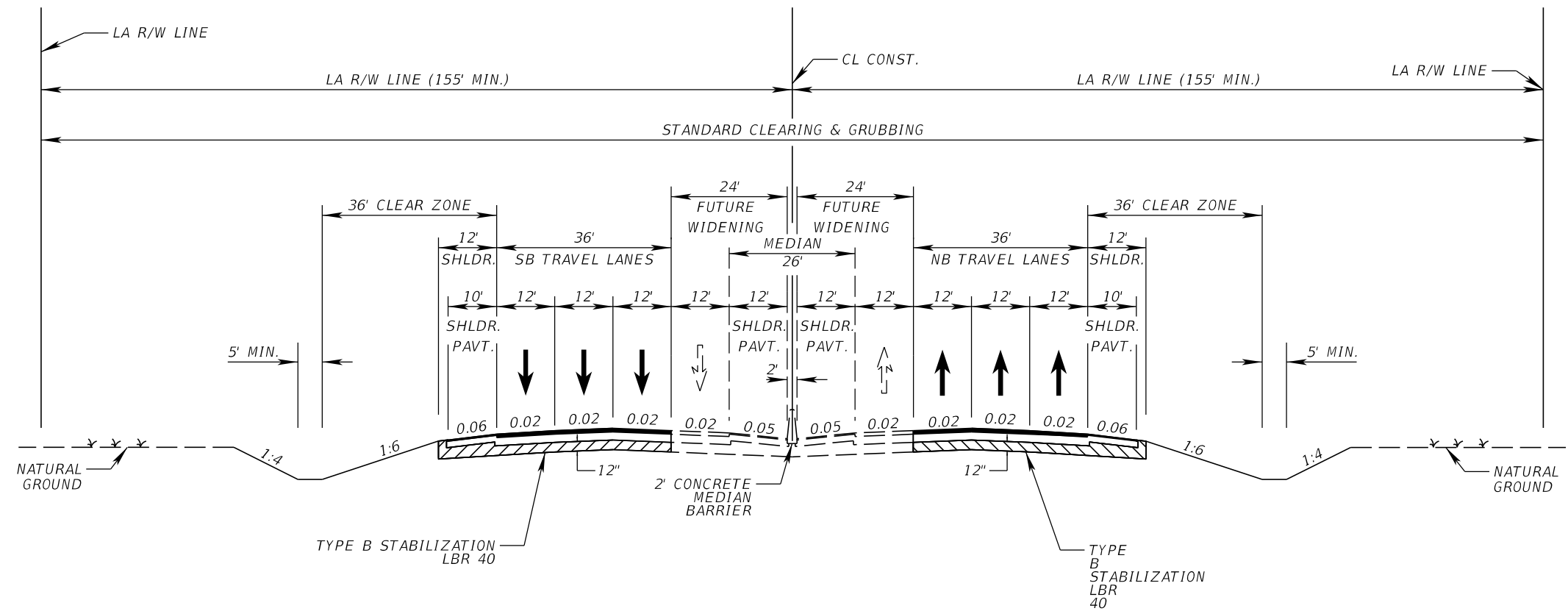
**CRITERIA**

- (X) NEW CONSTRUCTION / RECONSTRUCTION
- ( ) RESURFACING (LA FACILITIES)
- ( ) RRR (ARTERIALS & COLLECTORS)

**POTENTIAL EXCEPTIONS AND VARIATIONS RELATED TO TYPICAL SECTION:**

BORDER WIDTH DESIGN VARIATION MEMO

**TYPICAL SECTION No. 3**



PROPOSED 8-LANE TYPICAL SECTION  
POINCIANA PARKWAY EXTENSION  
FUTURE WIDENING (SR 538)  
FROM SR 532 TO I-4

**TRAFFIC DATA**

CURRENT YEAR = 2020 AADT = N/A  
 ESTIMATED OPENING YEAR = 2030 AADT = 12,000 (NB) 12,000 (SB)  
 ESTIMATED DESIGN YEAR = 2050 AADT = 23,000 (NB) 23,000 (SB)  
 K = 11.0% D = 60.0% T = 12.8% (24 HOUR)  
 DESIGN HOUR T = 7.0%  
 DESIGN SPEED = 70 MPH

FINANCIAL PROJECT ID	SHEET NO.
446581-1-22-01	5

THE OFFICIAL RECORD OF THIS SHEET IS THE ELECTRONIC FILE DIGITALLY SIGNED AND SEALED UNDER RULE 61G15-23.004, F.A.C.

**PROJECT CONTROLS**

**CONTEXT CLASSIFICATION**

- ( ) C1 : NATURAL                      ( ) C3C : SUBURBAN COMM.
- ( ) C2 : RURAL                        ( ) C4 : URBAN GENERAL
- ( ) C2T : RURAL TOWN                ( ) C5 : URBAN CENTER
- ( ) C3R : SUBURBAN RES.            ( ) C6 : URBAN CORE
- (X) N/A : L.A. FACILITY

**FUNCTIONAL CLASSIFICATION**

- ( ) INTERSTATE                        ( ) MAJOR COLLECTOR
- (X) FREEWAY/EXPWY.                ( ) MINOR COLLECTOR
- ( ) PRINCIPAL ARTERIAL            ( ) LOCAL
- ( ) MINOR ARTERIAL

**HIGHWAY SYSTEM**

- (X) NATIONAL HIGHWAY SYSTEM
- (X) STRATEGIC INTERMODAL SYSTEM
- (X) STATE HIGHWAY SYSTEM
- ( ) OFF-STATE HIGHWAY SYSTEM

**ACCESS CLASSIFICATION**

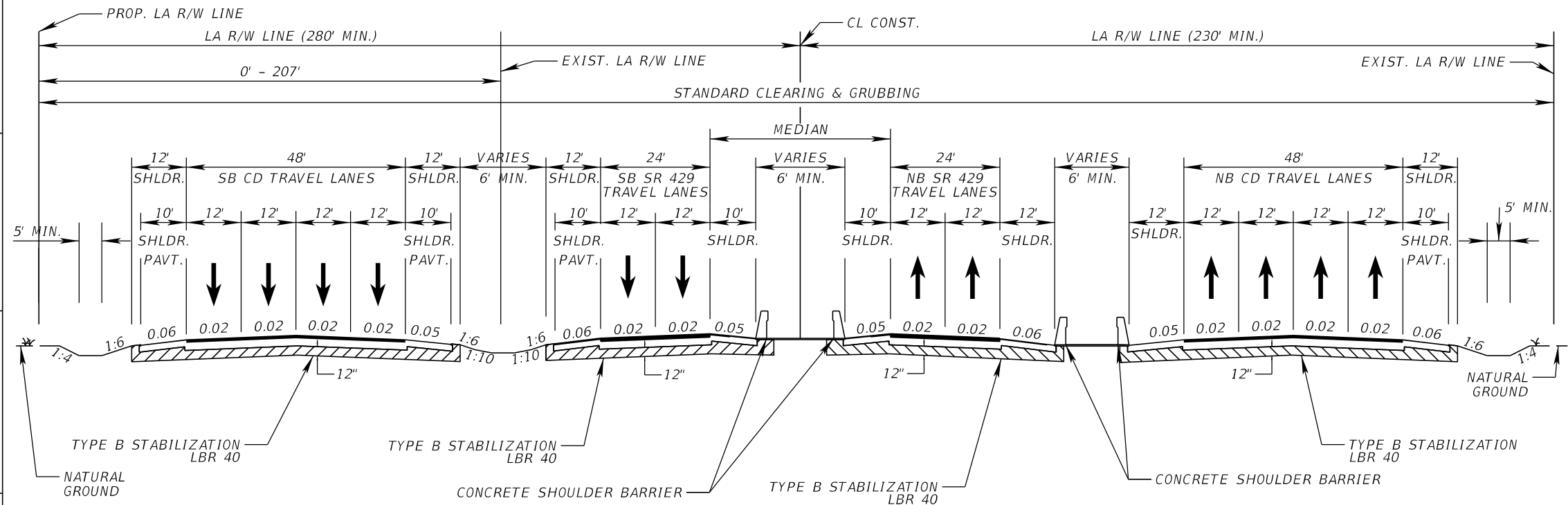
- (X) 1 - FREEWAY
- ( ) 2 - RESTRICTIVE w/Service Roads
- ( ) 3 - RESTRICTIVE w/660 ft. Connection Spacing
- ( ) 4 - NON-RESTRICTIVE w/2640 ft. Signal Spacing
- ( ) 5 - RESTRICTIVE w/440 ft. Connection Spacing
- ( ) 6 - NON-RESTRICTIVE w/1320 ft. Signal Spacing
- ( ) 7 - BOTH MEDIAN TYPES

**CRITERIA**

- (X) NEW CONSTRUCTION / RECONSTRUCTION
- ( ) RESURFACING (LA FACILITIES)
- ( ) RRR (ARTERIALS & COLLECTORS)

**POTENTIAL EXCEPTIONS AND VARIATIONS RELATED TO TYPICAL SECTION:**

**TYPICAL SECTION No. 4**



PROPOSED 4-LANE TYPICAL SECTION WITH 8-LANE CD SYSTEM SR 429 FROM I-4 TO SINCLAIR ROAD

**TRAFFIC DATA**

CURRENT YEAR = 2020 AADT = 13,400 (NB) 18,400 (SB)  
 ESTIMATED OPENING YEAR = 2030 AADT = 25,600 (NB) 25,600 (SB)  
 ESTIMATED DESIGN YEAR = 2050 AADT = 49,700 (NB) 49,700 (SB)  
 K = 10.5% D = 58.0% T = 12.8% (24 HOUR)  
 DESIGN HOUR T = 7.0%  
 DESIGN SPEED = 70 MPH

FINANCIAL PROJECT ID	SHEET NO.
446581-1-22-01	6

THE OFFICIAL RECORD OF THIS SHEET IS THE ELECTRONIC FILE DIGITALLY SIGNED AND SEALED UNDER RULE 61G15-23.004, F.A.C.

**PROJECT CONTROLS**

**CONTEXT CLASSIFICATION**

- ( ) C1 : NATURAL                      ( ) C3C : SUBURBAN COMM.
- ( ) C2 : RURAL                        ( ) C4 : URBAN GENERAL
- ( ) C2T : RURAL TOWN                ( ) C5 : URBAN CENTER
- ( ) C3R : SUBURBAN RES.            ( ) C6 : URBAN CORE
- (X) N/A : L.A. FACILITY

**FUNCTIONAL CLASSIFICATION**

- ( ) INTERSTATE                        ( ) MAJOR COLLECTOR
- (X) FREEWAY/EXPWY.                ( ) MINOR COLLECTOR
- ( ) PRINCIPAL ARTERIAL            ( ) LOCAL
- ( ) MINOR ARTERIAL

**HIGHWAY SYSTEM**

- (X) NATIONAL HIGHWAY SYSTEM
- (X) STRATEGIC INTERMODAL SYSTEM
- (X) STATE HIGHWAY SYSTEM
- ( ) OFF-STATE HIGHWAY SYSTEM

**ACCESS CLASSIFICATION**

- (X) 1 - FREEWAY
- ( ) 2 - RESTRICTIVE w/Service Roads
- ( ) 3 - RESTRICTIVE w/660 ft. Connection Spacing
- ( ) 4 - NON-RESTRICTIVE w/2640 ft. Signal Spacing
- ( ) 5 - RESTRICTIVE w/440 ft. Connection Spacing
- ( ) 6 - NON-RESTRICTIVE w/1320 ft. Signal Spacing
- ( ) 7 - BOTH MEDIAN TYPES

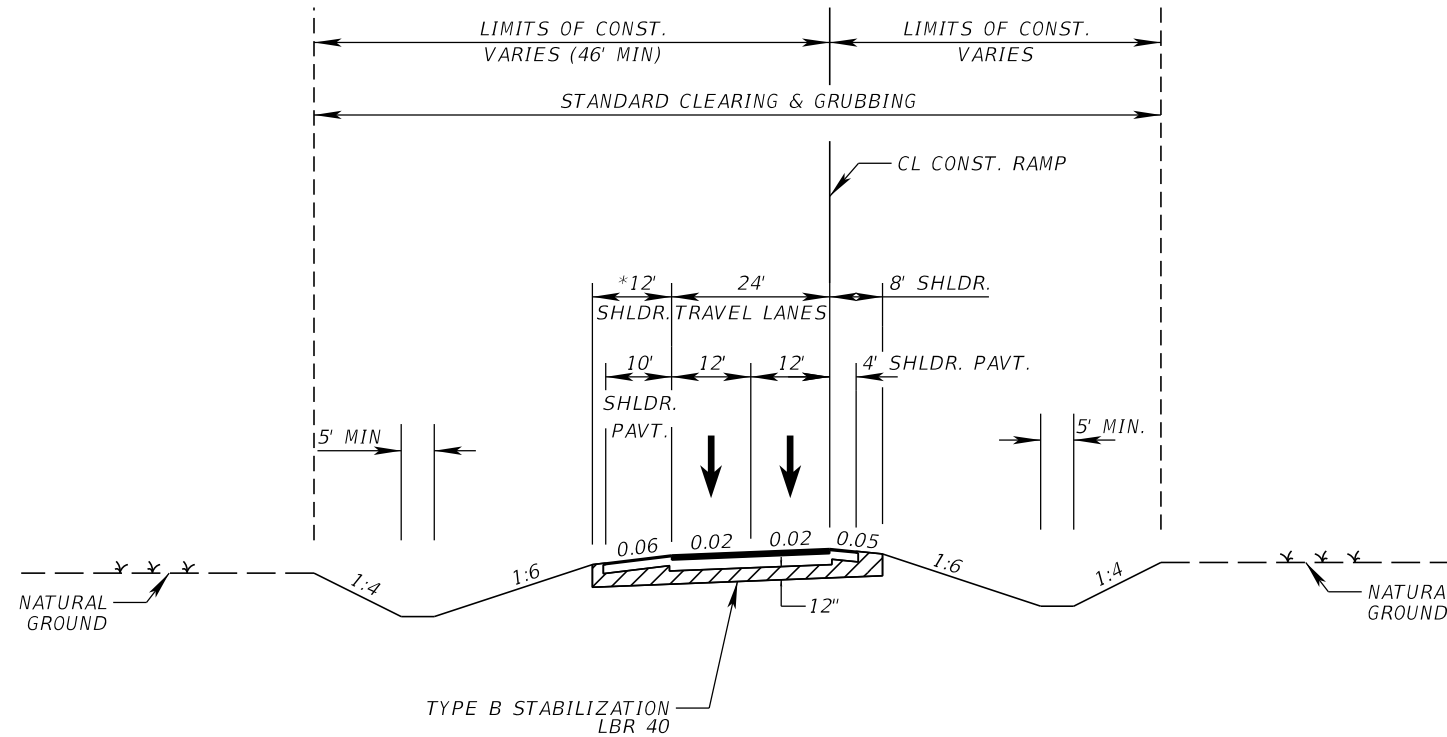
**CRITERIA**

- (X) NEW CONSTRUCTION / RECONSTRUCTION
- ( ) RESURFACING (LA FACILITIES)
- ( ) RRR (ARTERIALS & COLLECTORS)

**POTENTIAL EXCEPTIONS AND VARIATIONS RELATED TO TYPICAL SECTION:**

BORDER WIDTH DESIGN VARIATION MEMO

**TYPICAL SECTION No. 5a**



**PROPOSED 2-LANE RAMP TYPICAL SECTION  
POINCIANA PARKWAY EXTENSION (SR 538)**

\* PAVED SHOULDER WIDTH IS ADJUSTED ALONG HORIZONTAL CURVES FOR STOPPING SIGHT DISTANCE

FINANCIAL PROJECT ID	SHEET NO.
446581-1-22-01	7

THE OFFICIAL RECORD OF THIS SHEET IS THE ELECTRONIC FILE DIGITALLY SIGNED AND SEALED UNDER RULE 61G15-23.004, F.A.C.

**PROJECT CONTROLS**

**CONTEXT CLASSIFICATION**

- ( ) C1 : NATURAL                      ( ) C3C : SUBURBAN COMM.
- ( ) C2 : RURAL                        ( ) C4 : URBAN GENERAL
- ( ) C2T : RURAL TOWN                ( ) C5 : URBAN CENTER
- ( ) C3R : SUBURBAN RES.            ( ) C6 : URBAN CORE
- (X) N/A : L.A. FACILITY

**FUNCTIONAL CLASSIFICATION**

- ( ) INTERSTATE                        ( ) MAJOR COLLECTOR
- (X) FREEWAY/EXPWY.                ( ) MINOR COLLECTOR
- ( ) PRINCIPAL ARTERIAL            ( ) LOCAL
- ( ) MINOR ARTERIAL

**HIGHWAY SYSTEM**

- (X) NATIONAL HIGHWAY SYSTEM
- (X) STRATEGIC INTERMODAL SYSTEM
- (X) STATE HIGHWAY SYSTEM
- ( ) OFF-STATE HIGHWAY SYSTEM

**ACCESS CLASSIFICATION**

- (X) 1 - FREEWAY
- ( ) 2 - RESTRICTIVE w/Service Roads
- ( ) 3 - RESTRICTIVE w/660 ft. Connection Spacing
- ( ) 4 - NON-RESTRICTIVE w/2640 ft. Signal Spacing
- ( ) 5 - RESTRICTIVE w/440 ft. Connection Spacing
- ( ) 6 - NON-RESTRICTIVE w/1320 ft. Signal Spacing
- ( ) 7 - BOTH MEDIAN TYPES

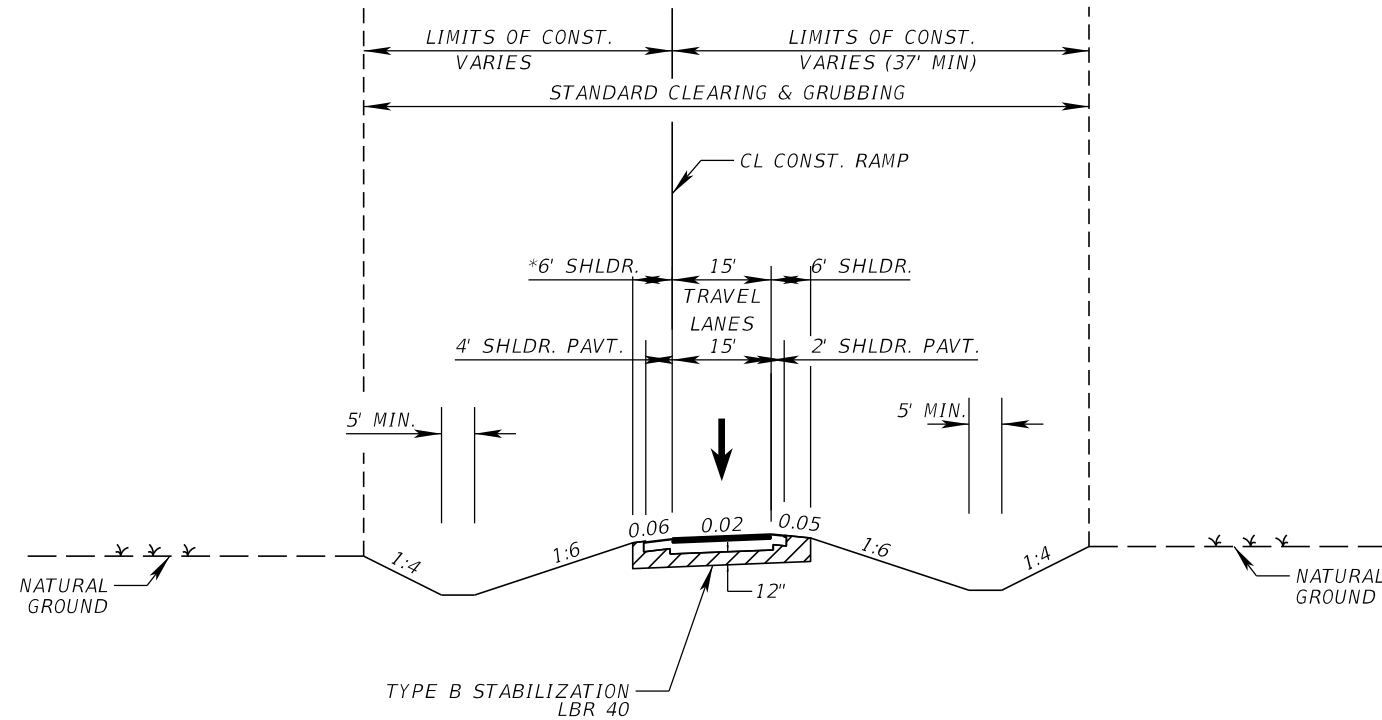
**CRITERIA**

- (X) NEW CONSTRUCTION / RECONSTRUCTION
- ( ) RESURFACING (LA FACILITIES)
- ( ) RRR (ARTERIALS & COLLECTORS)

**POTENTIAL EXCEPTIONS AND VARIATIONS RELATED TO TYPICAL SECTION:**

BORDER WIDTH DESIGN VARIATION MEMO

**TYPICAL SECTION No. 5b**



**PROPOSED 1-LANE RAMP TYPICAL SECTION  
POINCIANA PARKWAY EXTENSION (SR 538)**

\* PAVED SHOULDER WIDTH IS ADJUSTED ALONG HORIZONTAL CURVES FOR STOPPING SIGHT DISTANCE

FINANCIAL PROJECT ID	SHEET NO.
446581-1-22-01	8

THE OFFICIAL RECORD OF THIS SHEET IS THE ELECTRONIC FILE DIGITALLY SIGNED AND SEALED UNDER RULE 61G15-23.004, F.A.C.



**PROJECT CONTROLS**

**CONTEXT CLASSIFICATION**

- ( ) C1 : NATURAL            ( ) C3C : SUBURBAN COMM.
- ( ) C2 : RURAL            ( ) C4 : URBAN GENERAL
- ( ) C2T : RURAL TOWN    ( ) C5 : URBAN CENTER
- ( ) C3R : SUBURBAN RES. ( ) C6 : URBAN CORE
- (X) N/A : L.A. FACILITY

**FUNCTIONAL CLASSIFICATION**

- ( ) INTERSTATE            ( ) MAJOR COLLECTOR
- (X) FREEWAY/EXPWY.    ( ) MINOR COLLECTOR
- ( ) PRINCIPAL ARTERIAL   ( ) LOCAL
- ( ) MINOR ARTERIAL

**HIGHWAY SYSTEM**

- (X) NATIONAL HIGHWAY SYSTEM
- (X) STRATEGIC INTERMODAL SYSTEM
- (X) STATE HIGHWAY SYSTEM
- ( ) OFF-STATE HIGHWAY SYSTEM

**ACCESS CLASSIFICATION**

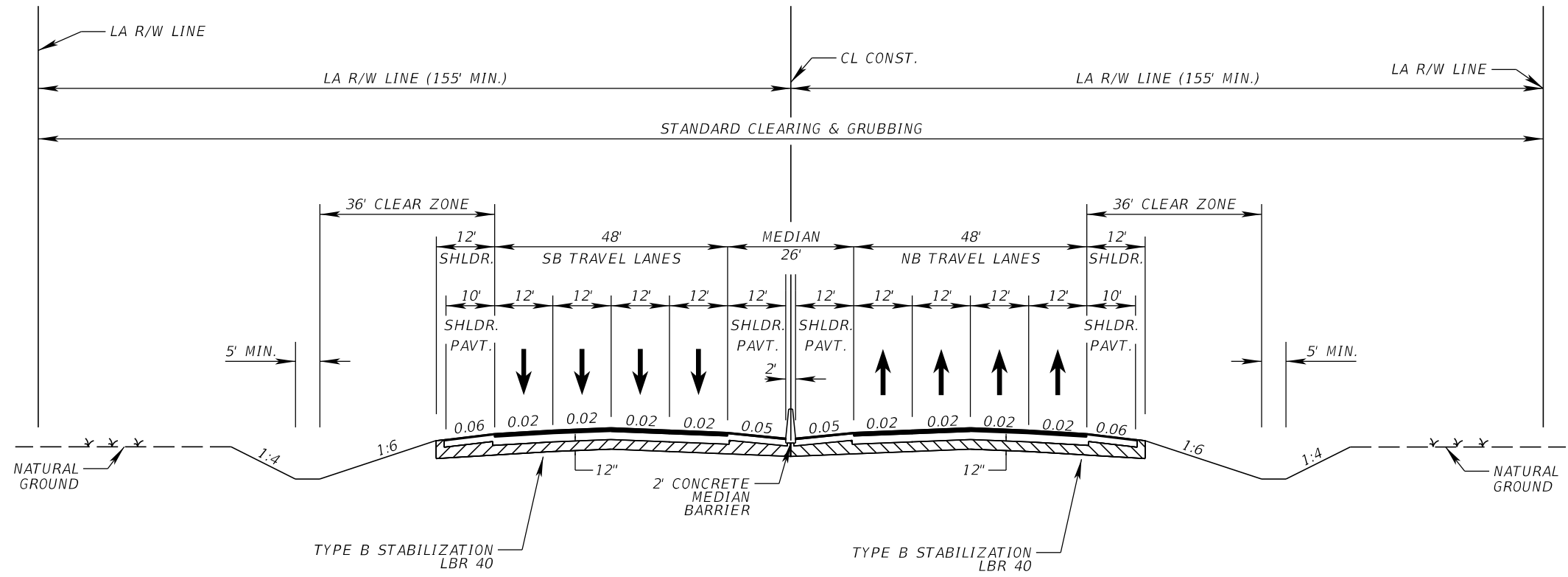
- (X) 1 - FREEWAY
- ( ) 2 - RESTRICTIVE w/Service Roads
- ( ) 3 - RESTRICTIVE w/660 ft. Connection Spacing
- ( ) 4 - NON-RESTRICTIVE w/2640 ft. Signal Spacing
- ( ) 5 - RESTRICTIVE w/440 ft. Connection Spacing
- ( ) 6 - NON-RESTRICTIVE w/1320 ft. Signal Spacing
- ( ) 7 - BOTH MEDIAN TYPES

**CRITERIA**

- (X) NEW CONSTRUCTION / RECONSTRUCTION
- ( ) RESURFACING (LA FACILITIES)
- ( ) RRR (ARTERIALS & COLLECTORS)

**POTENTIAL EXCEPTIONS AND VARIATIONS RELATED TO TYPICAL SECTION:**

**TYPICAL SECTION No. 6**



**PROPOSED 8-LANE TYPICAL SECTION**  
**POINCIANA PARKWAY EXTENSION**  
**SR 429**  
**FROM SINCLAIR ROAD TO**  
**NORTH OF SAND HILL ROAD**

**TRAFFIC DATA**

CURRENT YEAR            = 2020 AADT = 14,200 (NB) 19,100 (SB)  
 ESTIMATED OPENING YEAR = 2030 AADT = 25,400 (NB) 25,400 (SB)  
 ESTIMATED DESIGN YEAR = 2050 AADT = 48,200 (NB) 48,200 (SB)  
 K = 10.5% D = 58.0% T = 12.8% (24 HOUR)  
 DESIGN HOUR T = 7.0%  
 DESIGN SPEED = 70 MPH

FINANCIAL PROJECT ID	SHEET NO.
446581-1-22-01	9

THE OFFICIAL RECORD OF THIS SHEET IS THE ELECTRONIC FILE DIGITALLY SIGNED AND SEALED UNDER RULE 61G15-23.004, F.A.C.

**PROJECT CONTROLS**

**CONTEXT CLASSIFICATION**

- ( ) C1 : NATURAL            ( ) C3C : SUBURBAN COMM.
- ( ) C2 : RURAL            ( ) C4 : URBAN GENERAL
- ( ) C2T : RURAL TOWN    ( ) C5 : URBAN CENTER
- ( ) C3R : SUBURBAN RES. ( ) C6 : URBAN CORE
- (X) N/A : L.A. FACILITY

**FUNCTIONAL CLASSIFICATION**

- ( ) INTERSTATE            ( ) MAJOR COLLECTOR
- (X) FREEWAY/EXPWY.    ( ) MINOR COLLECTOR
- ( ) PRINCIPAL ARTERIAL   ( ) LOCAL
- ( ) MINOR ARTERIAL

**HIGHWAY SYSTEM**

- (X) NATIONAL HIGHWAY SYSTEM
- (X) STRATEGIC INTERMODAL SYSTEM
- (X) STATE HIGHWAY SYSTEM
- ( ) OFF-STATE HIGHWAY SYSTEM

**ACCESS CLASSIFICATION**

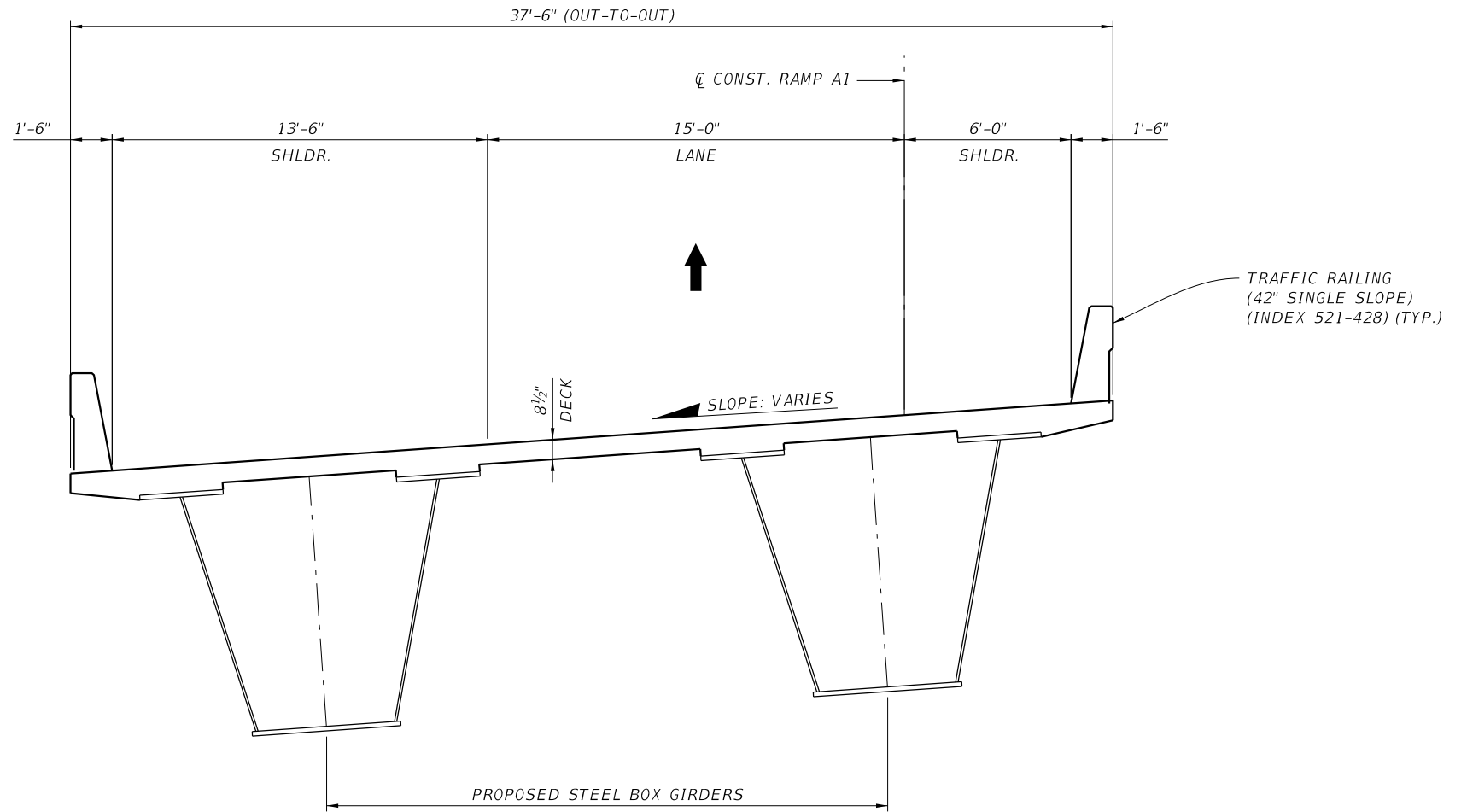
- (X) 1 - FREEWAY
- ( ) 2 - RESTRICTIVE w/Service Roads
- ( ) 3 - RESTRICTIVE w/660 ft. Connection Spacing
- ( ) 4 - NON-RESTRICTIVE w/2640 ft. Signal Spacing
- ( ) 5 - RESTRICTIVE w/440 ft. Connection Spacing
- ( ) 6 - NON-RESTRICTIVE w/1320 ft. Signal Spacing
- ( ) 7 - BOTH MEDIAN TYPES

**CRITERIA**

- (X) NEW CONSTRUCTION / RECONSTRUCTION
- ( ) RESURFACING (LA FACILITIES)
- ( ) RRR (ARTERIALS & COLLECTORS)

**POTENTIAL EXCEPTIONS AND VARIATIONS RELATED TO TYPICAL SECTION:**

**TYPICAL SECTION No. 7**



**RAMP A1 FLYOVER**

**TRAFFIC DATA**

Current Yr. - N/A AADT = N/A  
 Opening Yr. Est. - 2030 AADT = 600  
 Design Yr. Est. - 2050 AADT = 1,500  
 Design Speed = 50 MPH  
 K = 10.5%  
 D = 64.8%  
 T = 13.3%  
 Design Hour  
 T = 7.0%

**NOT TO SCALE**

FINANCIAL PROJECT ID	SHEET NO.
446581-1-22-01	10

THE OFFICIAL RECORD OF THIS SHEET IS THE ELECTRONIC FILE DIGITALLY SIGNED AND SEALED UNDER RULE 61G15-23.004, F.A.C.

**PROJECT CONTROLS**

CONTEXT CLASSIFICATION

- ( ) C1 : NATURAL            ( ) C3C : SUBURBAN COMM.
- ( ) C2 : RURAL            ( ) C4 : URBAN GENERAL
- ( ) C2T : RURAL TOWN    ( ) C5 : URBAN CENTER
- ( ) C3R : SUBURBAN RES. ( ) C6 : URBAN CORE
- (X) N/A : L.A. FACILITY

FUNCTIONAL CLASSIFICATION

- ( ) INTERSTATE            ( ) MAJOR COLLECTOR
- (X) FREEWAY/EXPWY.    ( ) MINOR COLLECTOR
- ( ) PRINCIPAL ARTERIAL   ( ) LOCAL
- ( ) MINOR ARTERIAL

HIGHWAY SYSTEM

- (X) NATIONAL HIGHWAY SYSTEM
- (X) STRATEGIC INTERMODAL SYSTEM
- (X) STATE HIGHWAY SYSTEM
- ( ) OFF-STATE HIGHWAY SYSTEM

ACCESS CLASSIFICATION

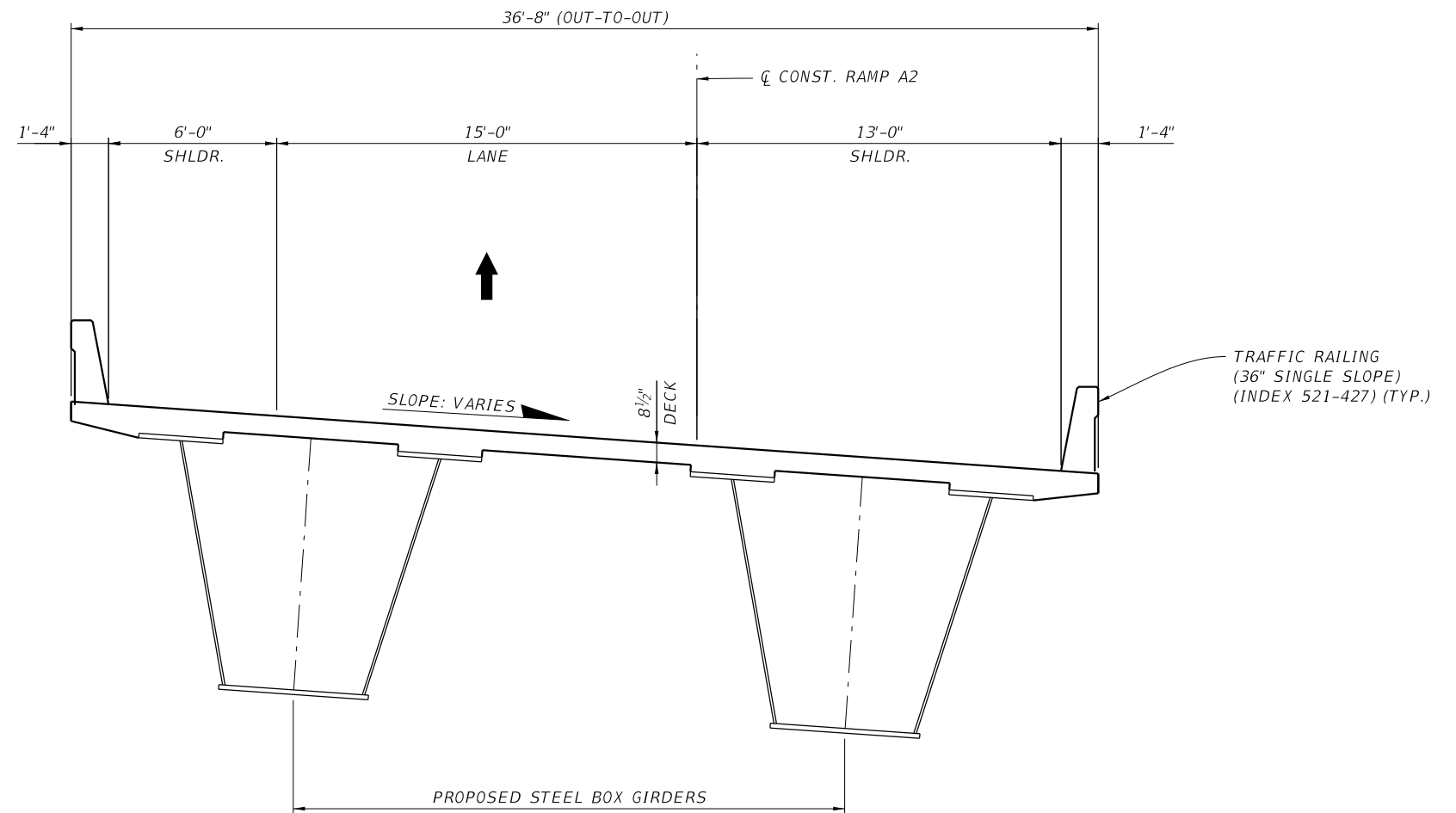
- (X) 1 - FREEWAY
- ( ) 2 - RESTRICTIVE w/Service Roads
- ( ) 3 - RESTRICTIVE w/660 ft. Connection Spacing
- ( ) 4 - NON-RESTRICTIVE w/2640 ft. Signal Spacing
- ( ) 5 - RESTRICTIVE w/440 ft. Connection Spacing
- ( ) 6 - NON-RESTRICTIVE w/1320 ft. Signal Spacing
- ( ) 7 - BOTH MEDIAN TYPES

CRITERIA

- (X) NEW CONSTRUCTION / RECONSTRUCTION
- ( ) RESURFACING (LA FACILITIES)
- ( ) RRR (ARTERIALS & COLLECTORS)

POTENTIAL EXCEPTIONS AND VARIATIONS RELATED TO TYPICAL SECTION:

**TYPICAL SECTION No. 8**



**RAMP A2 OVER WB I-4**

**TRAFFIC DATA**

Current Yr. - N/A AADT = N/A  
 Opening Yr. Est. - 2030 AADT = N/A  
 Design Yr. Est. - 2050 AADT = 6,800  
 Design Speed = 50 MPH  
 K = 10.5%  
 D = 64.9%  
 T = 13.3%  
 Design Hour  
 T = 7.0%

**NOT TO SCALE**

FINANCIAL PROJECT ID	SHEET NO.
446581-1-22-01	11

**PROJECT CONTROLS**

**CONTEXT CLASSIFICATION**

- ( ) C1 : NATURAL            ( ) C3C : SUBURBAN COMM.
- ( ) C2 : RURAL            ( ) C4 : URBAN GENERAL
- ( ) C2T : RURAL TOWN    ( ) C5 : URBAN CENTER
- ( ) C3R : SUBURBAN RES. ( ) C6 : URBAN CORE
- (X) N/A : L.A. FACILITY

**FUNCTIONAL CLASSIFICATION**

- ( ) INTERSTATE            ( ) MAJOR COLLECTOR
- (X) FREEWAY/EXPWY.    ( ) MINOR COLLECTOR
- ( ) PRINCIPAL ARTERIAL   ( ) LOCAL
- ( ) MINOR ARTERIAL

**HIGHWAY SYSTEM**

- (X) NATIONAL HIGHWAY SYSTEM
- (X) STRATEGIC INTERMODAL SYSTEM
- (X) STATE HIGHWAY SYSTEM
- ( ) OFF-STATE HIGHWAY SYSTEM

**ACCESS CLASSIFICATION**

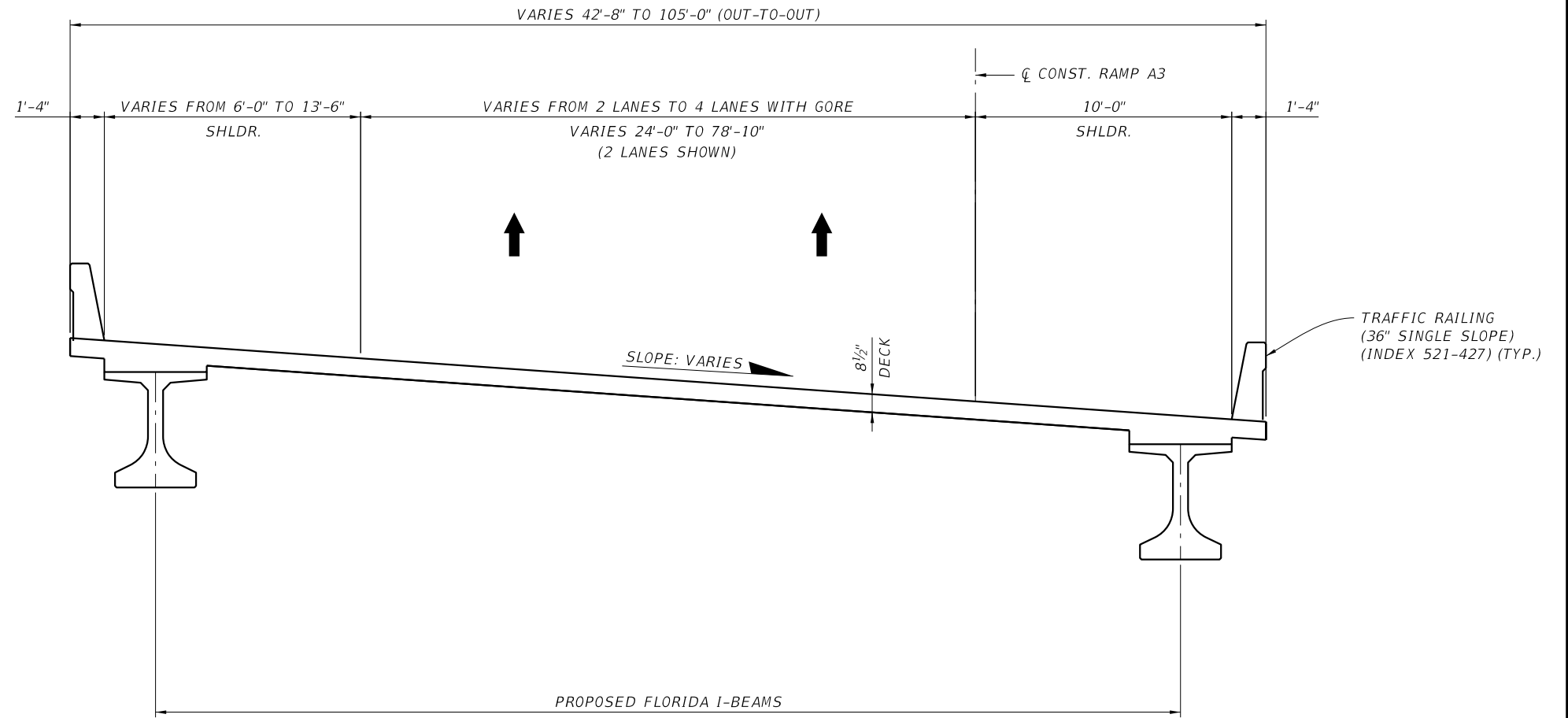
- (X) 1 - FREEWAY
- ( ) 2 - RESTRICTIVE w/Service Roads
- ( ) 3 - RESTRICTIVE w/660 ft. Connection Spacing
- ( ) 4 - NON-RESTRICTIVE w/2640 ft. Signal Spacing
- ( ) 5 - RESTRICTIVE w/440 ft. Connection Spacing
- ( ) 6 - NON-RESTRICTIVE w/1320 ft. Signal Spacing
- ( ) 7 - BOTH MEDIAN TYPES

**CRITERIA**

- (X) NEW CONSTRUCTION / RECONSTRUCTION
- ( ) RESURFACING (LA FACILITIES)
- ( ) RRR (ARTERIALS & COLLECTORS)

**POTENTIAL EXCEPTIONS AND VARIATIONS RELATED TO TYPICAL SECTION:**

**TYPICAL SECTION No. 9**



**RAMP A3 OVER POND**

**TRAFFIC DATA**

Current Yr. - 2020AADT = 14,600  
 Opening Yr. Est. - 2030 AADT = 15,800  
 Design Yr. Est. - 2050 AADT = 22,800  
 Design Speed = 50 MPH  
 K = 10.5%  
 D = 64.9%  
 T = 13.3%  
 Design Hour  
 T = 7.0%

**NOT TO SCALE**

FINANCIAL PROJECT ID	SHEET NO.
446581-1-22-01	12

THE OFFICIAL RECORD OF THIS SHEET IS THE ELECTRONIC FILE DIGITALLY SIGNED AND SEALED UNDER RULE 61G15-23.004, F.A.C.

**PROJECT CONTROLS**

**CONTEXT CLASSIFICATION**

- ( ) C1 : NATURAL            ( ) C3C : SUBURBAN COMM.
- ( ) C2 : RURAL            ( ) C4 : URBAN GENERAL
- ( ) C2T : RURAL TOWN    ( ) C5 : URBAN CENTER
- ( ) C3R : SUBURBAN RES. ( ) C6 : URBAN CORE
- (X) N/A : L.A. FACILITY

**FUNCTIONAL CLASSIFICATION**

- ( ) INTERSTATE            ( ) MAJOR COLLECTOR
- (X) FREEWAY/EXPWY.    ( ) MINOR COLLECTOR
- ( ) PRINCIPAL ARTERIAL   ( ) LOCAL
- ( ) MINOR ARTERIAL

**HIGHWAY SYSTEM**

- (X) NATIONAL HIGHWAY SYSTEM
- (X) STRATEGIC INTERMODAL SYSTEM
- (X) STATE HIGHWAY SYSTEM
- ( ) OFF-STATE HIGHWAY SYSTEM

**ACCESS CLASSIFICATION**

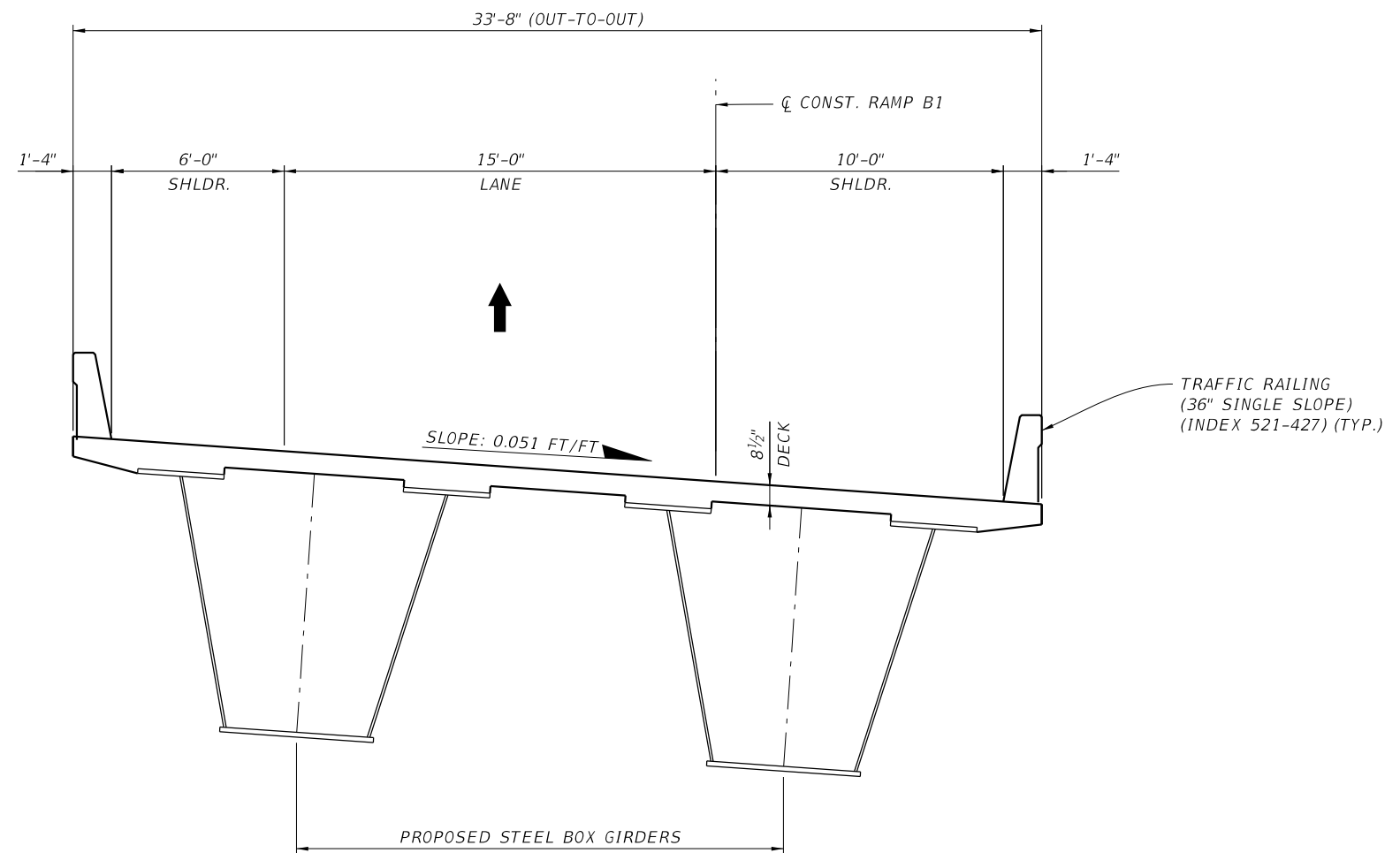
- (X) 1 - FREEWAY
- ( ) 2 - RESTRICTIVE w/Service Roads
- ( ) 3 - RESTRICTIVE w/660 ft. Connection Spacing
- ( ) 4 - NON-RESTRICTIVE w/2640 ft. Signal Spacing
- ( ) 5 - RESTRICTIVE w/440 ft. Connection Spacing
- ( ) 6 - NON-RESTRICTIVE w/1320 ft. Signal Spacing
- ( ) 7 - BOTH MEDIAN TYPES

**CRITERIA**

- (X) NEW CONSTRUCTION / RECONSTRUCTION
- ( ) RESURFACING (LA FACILITIES)
- ( ) RRR (ARTERIALS & COLLECTORS)

**POTENTIAL EXCEPTIONS AND VARIATIONS RELATED TO TYPICAL SECTION:**

**TYPICAL SECTION No. 10**



**RAMP B1 OVER EB I-4**

**TRAFFIC DATA**

Current Yr. - N/A AADT = N/A  
 Opening Yr. Est. - 2030 AADT = N/A  
 Design Yr. Est. - 2050 AADT = 6,800  
 Design Speed = 50 MPH  
 K = 10.5%  
 D = 64.9%  
 T = 13.3%  
 Design Hour  
 T = 7.0%

**NOT TO SCALE**

FINANCIAL PROJECT ID	SHEET NO.
446581-1-22-01	13

THE OFFICIAL RECORD OF THIS SHEET IS THE ELECTRONIC FILE DIGITALLY SIGNED AND SEALED UNDER RULE 61G15-23.004, F.A.C.



**PROJECT CONTROLS**

**CONTEXT CLASSIFICATION**

- ( ) C1 : NATURAL            ( ) C3C : SUBURBAN COMM.
- ( ) C2 : RURAL            ( ) C4 : URBAN GENERAL
- ( ) C2T : RURAL TOWN    ( ) C5 : URBAN CENTER
- ( ) C3R : SUBURBAN RES. ( ) C6 : URBAN CORE
- (X) N/A : L.A. FACILITY

**FUNCTIONAL CLASSIFICATION**

- ( ) INTERSTATE            ( ) MAJOR COLLECTOR
- (X) FREEWAY/EXPWY.    ( ) MINOR COLLECTOR
- ( ) PRINCIPAL ARTERIAL   ( ) LOCAL
- ( ) MINOR ARTERIAL

**HIGHWAY SYSTEM**

- (X) NATIONAL HIGHWAY SYSTEM
- (X) STRATEGIC INTERMODAL SYSTEM
- (X) STATE HIGHWAY SYSTEM
- ( ) OFF-STATE HIGHWAY SYSTEM

**ACCESS CLASSIFICATION**

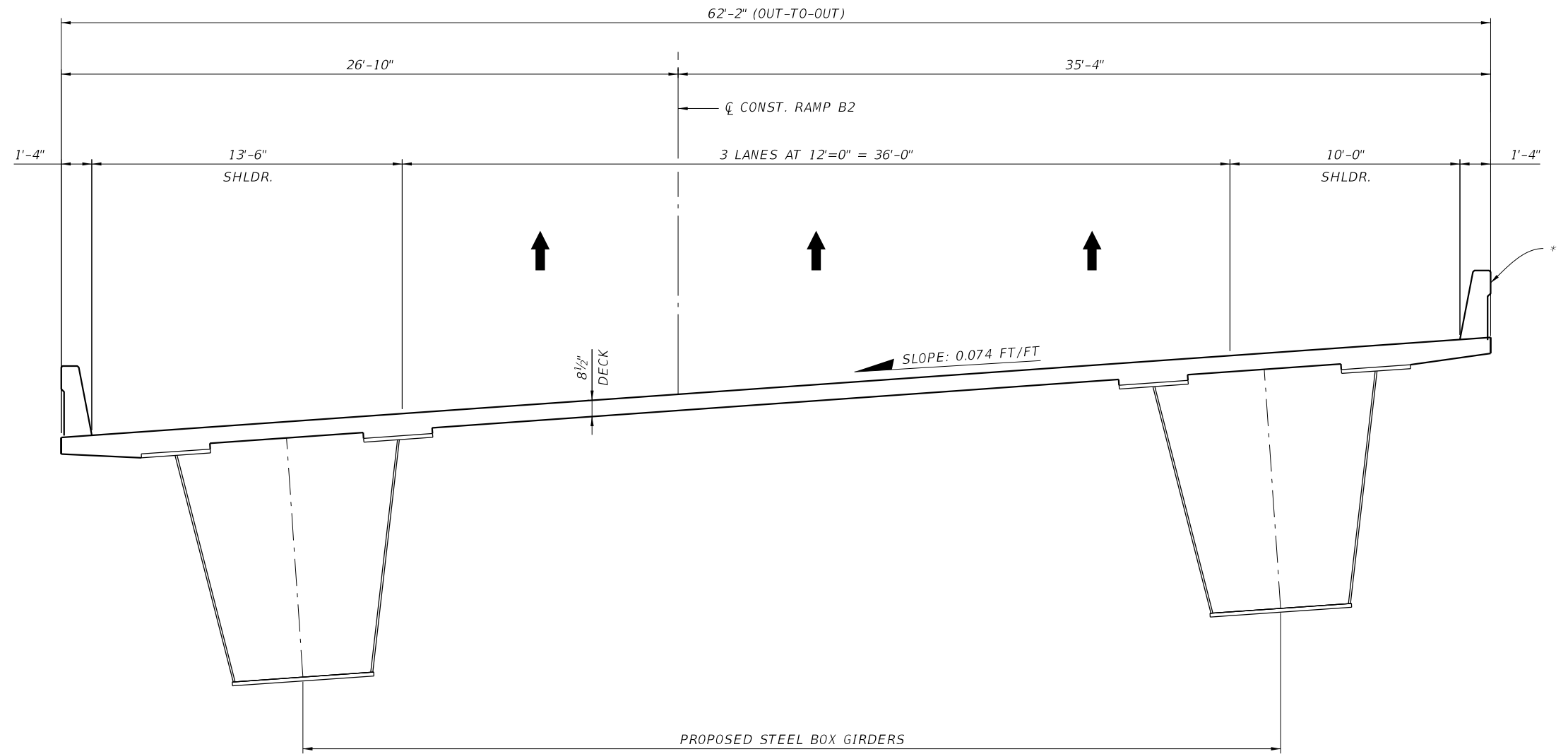
- (X) 1 - FREEWAY
- ( ) 2 - RESTRICTIVE w/Service Roads
- ( ) 3 - RESTRICTIVE w/660 ft. Connection Spacing
- ( ) 4 - NON-RESTRICTIVE w/2640 ft. Signal Spacing
- ( ) 5 - RESTRICTIVE w/440 ft. Connection Spacing
- ( ) 6 - NON-RESTRICTIVE w/1320 ft. Signal Spacing
- ( ) 7 - BOTH MEDIAN TYPES

**CRITERIA**

- (X) NEW CONSTRUCTION / RECONSTRUCTION
- ( ) RESURFACING (LA FACILITIES)
- ( ) RRR (ARTERIALS & COLLECTORS)

**POTENTIAL EXCEPTIONS AND VARIATIONS RELATED TO TYPICAL SECTION:**

**TYPICAL SECTION No. 11**



**RAMP B2 OVER I-4**

**TRAFFIC DATA**

Current Yr. - 2020 AADT = 2,200  
 Opening Yr. Est. - 2030 AADT = 15,800  
 Design Yr. Est. - 2050 AADT = 29,600  
 Design Speed = 50 MPH  
 K = 10.5%  
 D = 64.9%  
 T = 13.3%  
 Design Hour  
 T = 7.0%

\* TRAFFIC RAILING  
 (36" SINGLE SLOPE)  
 (INDEX 521-427) (TYP.)

**NOT TO SCALE**

FINANCIAL PROJECT ID	SHEET NO.
446581-1-22-01	14

**PROJECT CONTROLS**

**CONTEXT CLASSIFICATION**

- ( ) C1 : NATURAL                      ( ) C3C : SUBURBAN COMM.
- ( ) C2 : RURAL                        ( ) C4 : URBAN GENERAL
- ( ) C2T : RURAL TOWN                ( ) C5 : URBAN CENTER
- ( ) C3R : SUBURBAN RES.            ( ) C6 : URBAN CORE
- (X) N/A : L.A. FACILITY

**FUNCTIONAL CLASSIFICATION**

- ( ) INTERSTATE                        ( ) MAJOR COLLECTOR
- (X) FREEWAY/EXPWY.                ( ) MINOR COLLECTOR
- ( ) PRINCIPAL ARTERIAL              ( ) LOCAL
- ( ) MINOR ARTERIAL

**HIGHWAY SYSTEM**

- (X) NATIONAL HIGHWAY SYSTEM
- (X) STRATEGIC INTERMODAL SYSTEM
- (X) STATE HIGHWAY SYSTEM
- ( ) OFF-STATE HIGHWAY SYSTEM

**ACCESS CLASSIFICATION**

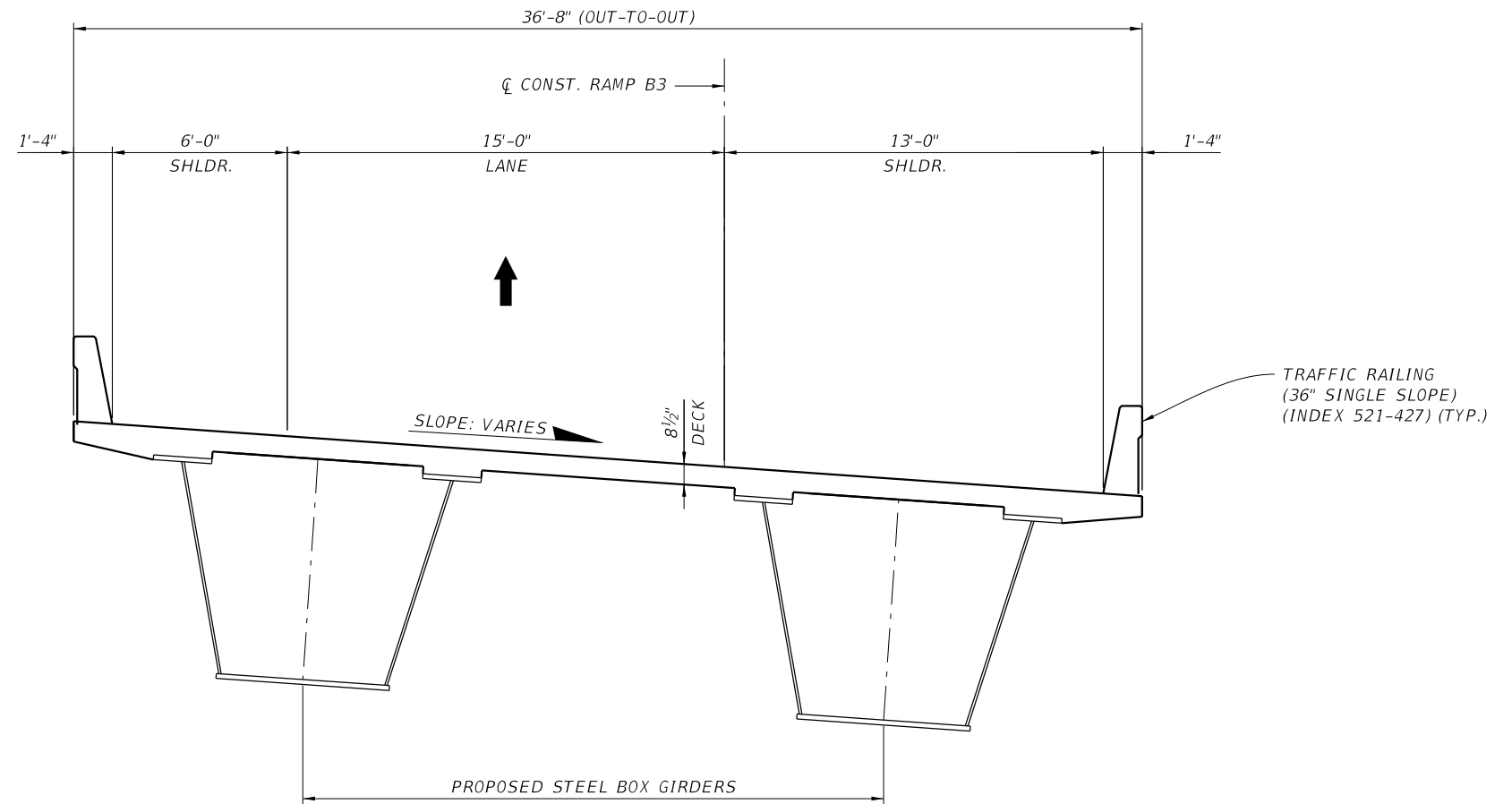
- (X) 1 - FREEWAY
- ( ) 2 - RESTRICTIVE w/Service Roads
- ( ) 3 - RESTRICTIVE w/660 ft. Connection Spacing
- ( ) 4 - NON-RESTRICTIVE w/2640 ft. Signal Spacing
- ( ) 5 - RESTRICTIVE w/440 ft. Connection Spacing
- ( ) 6 - NON-RESTRICTIVE w/1320 ft. Signal Spacing
- ( ) 7 - BOTH MEDIAN TYPES

**CRITERIA**

- (X) NEW CONSTRUCTION / RECONSTRUCTION
- ( ) RESURFACING (LA FACILITIES)
- ( ) RRR (ARTERIALS & COLLECTORS)

**POTENTIAL EXCEPTIONS AND VARIATIONS RELATED TO TYPICAL SECTION:**

**TYPICAL SECTION No. 12**



**RAMP B3 FLYOVER**

**TRAFFIC DATA**

Current Yr. - N/A AADT = N/A  
 Opening Yr. Est. - 2030 AADT = 600  
 Design Yr. Est. - 2050 AADT = 1,500  
 Design Speed = 50 MPH  
 K = 10.5%  
 D = 64.8%  
 T = 13.3%  
 Design Hour  
 T = 7.0%

**NOT TO SCALE**

FINANCIAL PROJECT ID	SHEET NO.
446581-1-22-01	15

THE OFFICIAL RECORD OF THIS SHEET IS THE ELECTRONIC FILE DIGITALLY SIGNED AND SEALED UNDER RULE 61G15-23.004, F.A.C.

**PROJECT CONTROLS**

**CONTEXT CLASSIFICATION**

- ( ) C1 : NATURAL            ( ) C3C : SUBURBAN COMM.
- ( ) C2 : RURAL            ( ) C4 : URBAN GENERAL
- ( ) C2T : RURAL TOWN    ( ) C5 : URBAN CENTER
- ( ) C3R : SUBURBAN RES. ( ) C6 : URBAN CORE
- (X) N/A : L.A. FACILITY

**FUNCTIONAL CLASSIFICATION**

- ( ) INTERSTATE            ( ) MAJOR COLLECTOR
- (X) FREEWAY/EXPWY.    ( ) MINOR COLLECTOR
- ( ) PRINCIPAL ARTERIAL   ( ) LOCAL
- ( ) MINOR ARTERIAL

**HIGHWAY SYSTEM**

- (X) NATIONAL HIGHWAY SYSTEM
- (X) STRATEGIC INTERMODAL SYSTEM
- (X) STATE HIGHWAY SYSTEM
- ( ) OFF-STATE HIGHWAY SYSTEM

**ACCESS CLASSIFICATION**

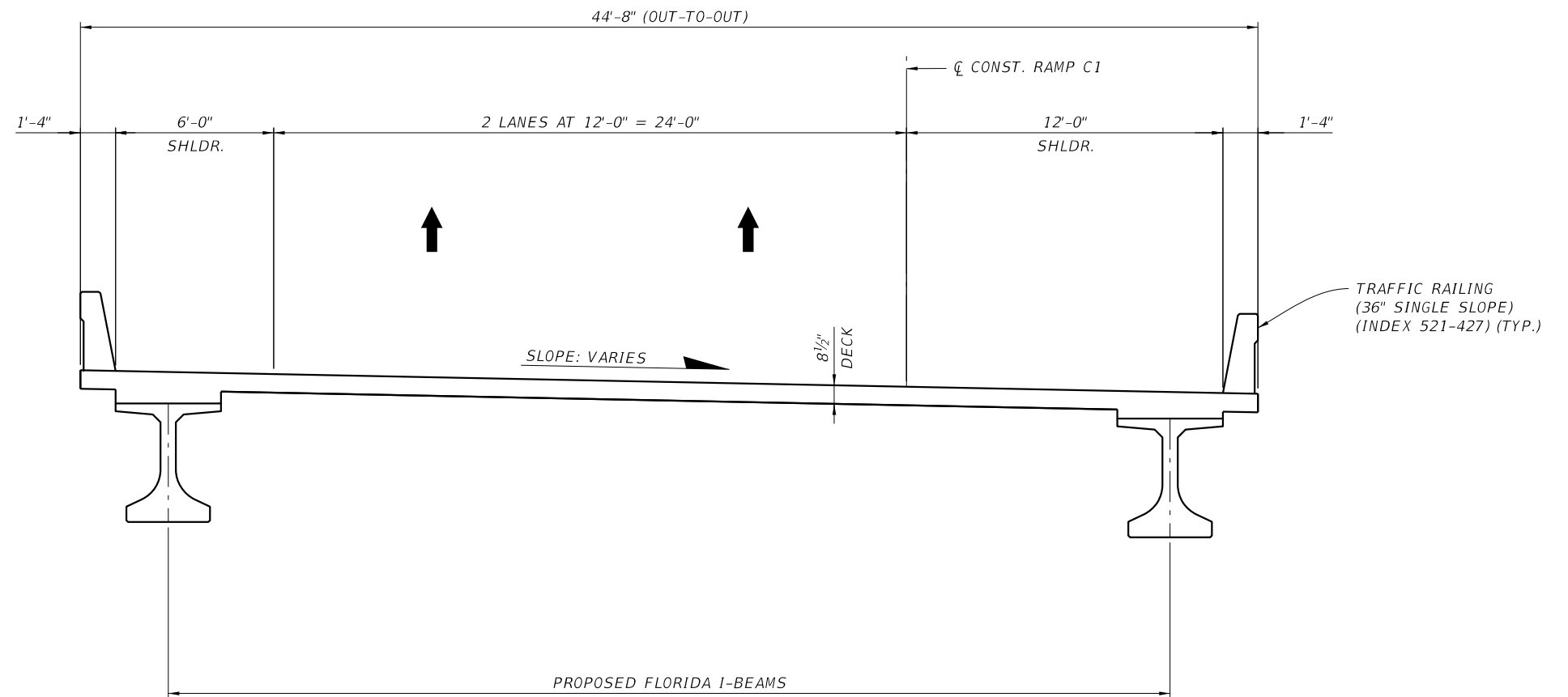
- (X) 1 - FREEWAY
- ( ) 2 - RESTRICTIVE w/Service Roads
- ( ) 3 - RESTRICTIVE w/660 ft. Connection Spacing
- ( ) 4 - NON-RESTRICTIVE w/2640 ft. Signal Spacing
- ( ) 5 - RESTRICTIVE w/440 ft. Connection Spacing
- ( ) 6 - NON-RESTRICTIVE w/1320 ft. Signal Spacing
- ( ) 7 - BOTH MEDIAN TYPES

**CRITERIA**

- (X) NEW CONSTRUCTION / RECONSTRUCTION
- ( ) RESURFACING (LA FACILITIES)
- ( ) RRR (ARTERIALS & COLLECTORS)

**POTENTIAL EXCEPTIONS AND VARIATIONS RELATED TO TYPICAL SECTION:**

**TYPICAL SECTION No. 13**



**RAMP C1 OVER DAVENPORT CREEK**

**TRAFFIC DATA**

Current Yr. - N/A AADT = N/A  
 Opening Yr. Est. - 2030 AADT = 7,600  
 Design Yr. Est. - 2050 AADT = 12,700  
 Design Speed = 50 MPH  
 K = 10.5%  
 D = 64.8%  
 T = 13.3%  
 Design Hour  
 T = 7.0%

**NOT TO SCALE**

FINANCIAL PROJECT ID	SHEET NO.
446581-1-22-01	16

THE OFFICIAL RECORD OF THIS SHEET IS THE ELECTRONIC FILE DIGITALLY SIGNED AND SEALED UNDER RULE 61G15-23.004, F.A.C.

**PROJECT CONTROLS**

**CONTEXT CLASSIFICATION**

- ( ) C1 : NATURAL            ( ) C3C : SUBURBAN COMM.
- ( ) C2 : RURAL            ( ) C4 : URBAN GENERAL
- ( ) C2T : RURAL TOWN    ( ) C5 : URBAN CENTER
- ( ) C3R : SUBURBAN RES. ( ) C6 : URBAN CORE
- (X) N/A : L.A. FACILITY

**FUNCTIONAL CLASSIFICATION**

- ( ) INTERSTATE            ( ) MAJOR COLLECTOR
- (X) FREEWAY/EXPWY.    ( ) MINOR COLLECTOR
- ( ) PRINCIPAL ARTERIAL   ( ) LOCAL
- ( ) MINOR ARTERIAL

**HIGHWAY SYSTEM**

- (X) NATIONAL HIGHWAY SYSTEM
- (X) STRATEGIC INTERMODAL SYSTEM
- (X) STATE HIGHWAY SYSTEM
- ( ) OFF-STATE HIGHWAY SYSTEM

**ACCESS CLASSIFICATION**

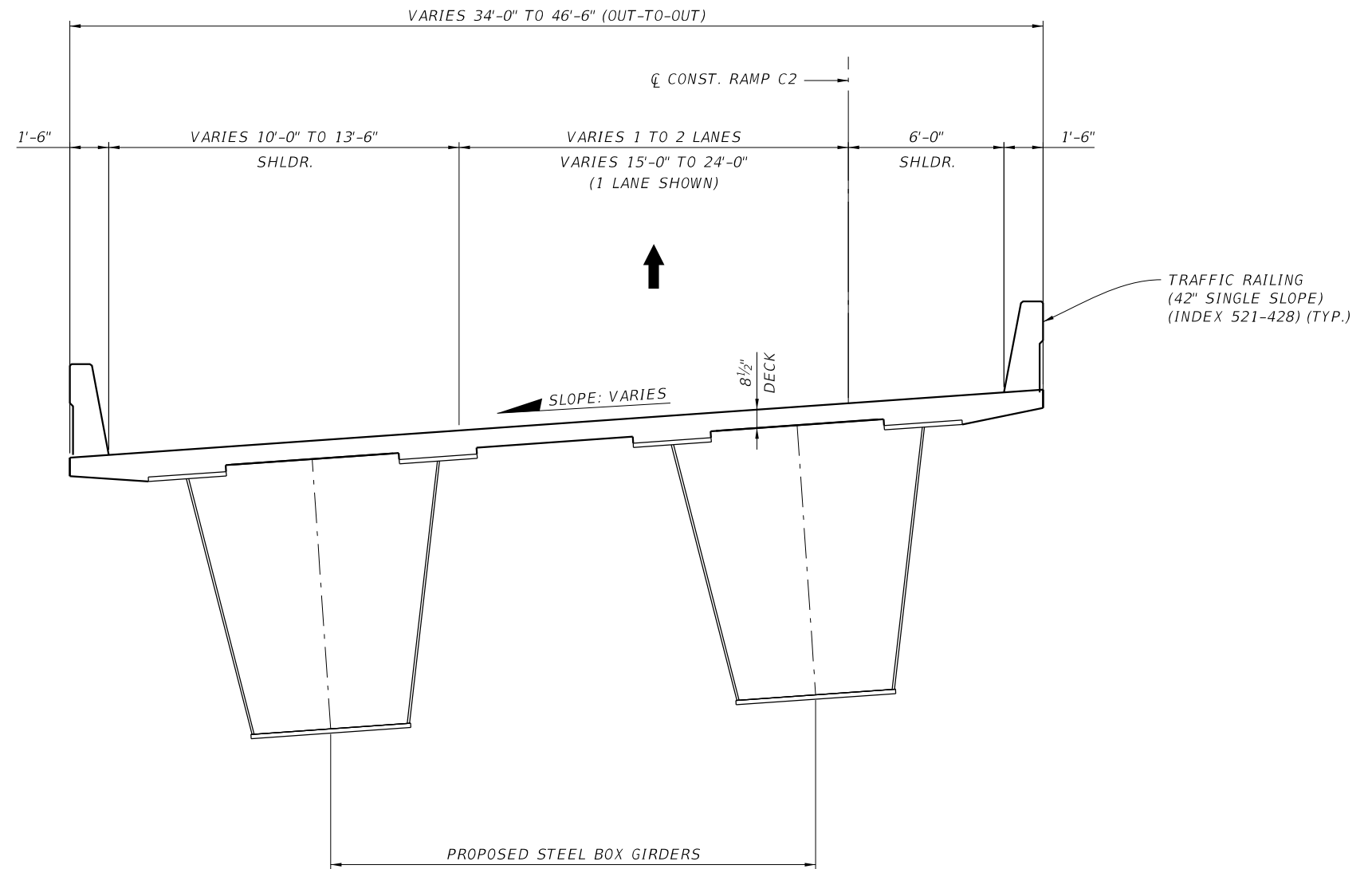
- (X) 1 - FREEWAY
- ( ) 2 - RESTRICTIVE w/Service Roads
- ( ) 3 - RESTRICTIVE w/660 ft. Connection Spacing
- ( ) 4 - NON-RESTRICTIVE w/2640 ft. Signal Spacing
- ( ) 5 - RESTRICTIVE w/440 ft. Connection Spacing
- ( ) 6 - NON-RESTRICTIVE w/1320 ft. Signal Spacing
- ( ) 7 - BOTH MEDIAN TYPES

**CRITERIA**

- (X) NEW CONSTRUCTION / RECONSTRUCTION
- ( ) RESURFACING (LA FACILITIES)
- ( ) RRR (ARTERIALS & COLLECTORS)

**POTENTIAL EXCEPTIONS AND VARIATIONS RELATED TO TYPICAL SECTION:**

**TYPICAL SECTION No. 14**



**RAMP C2 FLYOVER**

**TRAFFIC DATA**

Current Yr. - 2020 AADT = 3,800  
 Opening Yr. Est. - 2030 AADT = 6,000  
 Design Yr. Est. - 2050 AADT = 11,300  
 Design Speed = 50 MPH  
 K = 10.5%  
 D = 64.9%  
 T = 13.3%  
 Design Hour  
 T = 7.0%

**NOT TO SCALE**

FINANCIAL PROJECT ID	SHEET NO.
446581-1-22-01	17

THE OFFICIAL RECORD OF THIS SHEET IS THE ELECTRONIC FILE DIGITALLY SIGNED AND SEALED UNDER RULE 61G15-23.004, F.A.C.

**PROJECT CONTROLS**

CONTEXT CLASSIFICATION

- ( ) C1 : NATURAL                      ( ) C3C : SUBURBAN COMM.
- ( ) C2 : RURAL                        ( ) C4 : URBAN GENERAL
- ( ) C2T : RURAL TOWN                ( ) C5 : URBAN CENTER
- ( ) C3R : SUBURBAN RES.            ( ) C6 : URBAN CORE
- (X) N/A : L.A. FACILITY

FUNCTIONAL CLASSIFICATION

- ( ) INTERSTATE                        ( ) MAJOR COLLECTOR
- (X) FREEWAY/EXPWY.                ( ) MINOR COLLECTOR
- ( ) PRINCIPAL ARTERIAL              ( ) LOCAL
- ( ) MINOR ARTERIAL

HIGHWAY SYSTEM

- (X) NATIONAL HIGHWAY SYSTEM
- (X) STRATEGIC INTERMODAL SYSTEM
- (X) STATE HIGHWAY SYSTEM
- ( ) OFF-STATE HIGHWAY SYSTEM

ACCESS CLASSIFICATION

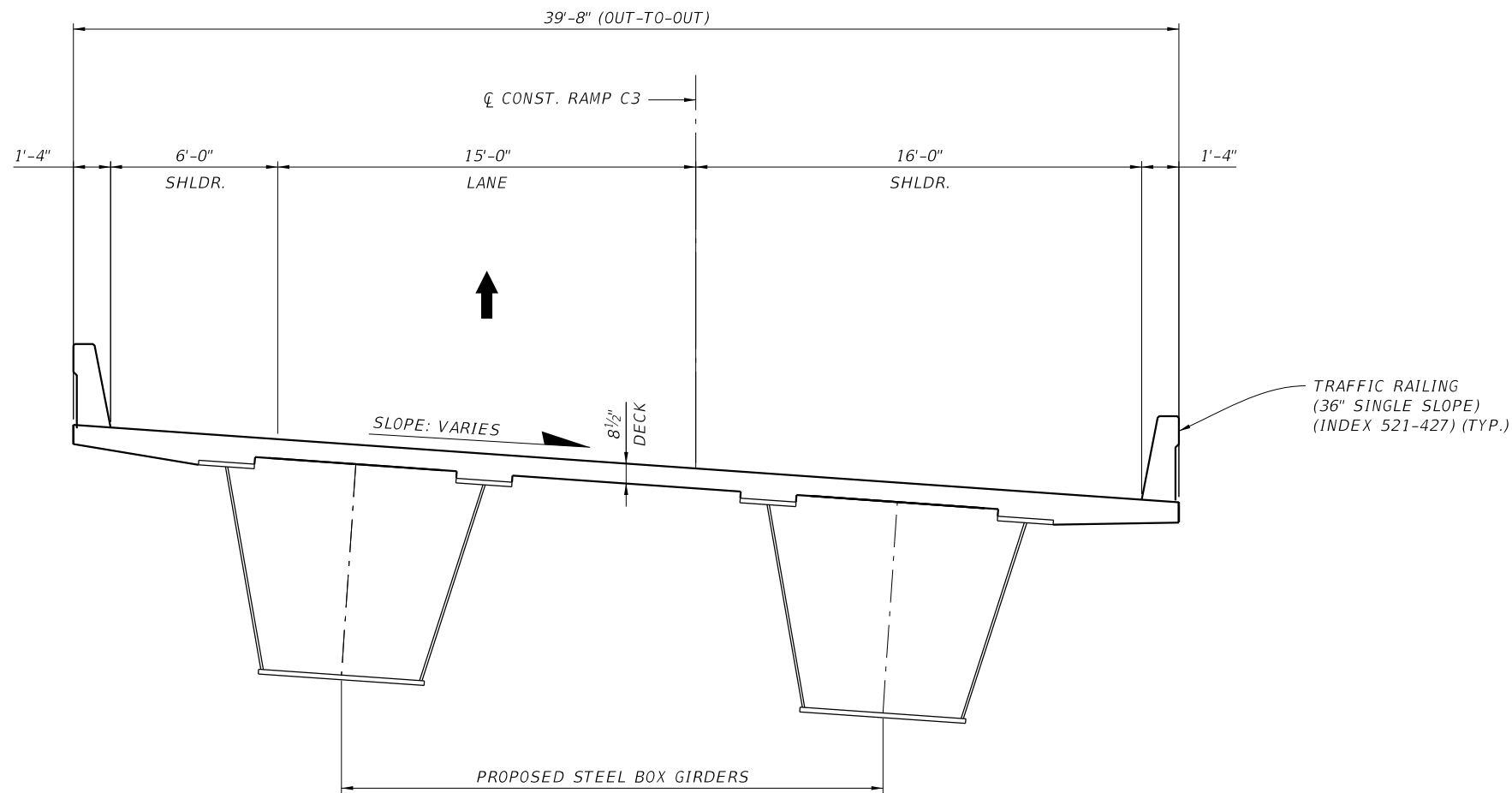
- (X) 1 - FREEWAY
- ( ) 2 - RESTRICTIVE w/Service Roads
- ( ) 3 - RESTRICTIVE w/660 ft. Connection Spacing
- ( ) 4 - NON-RESTRICTIVE w/2640 ft. Signal Spacing
- ( ) 5 - RESTRICTIVE w/440 ft. Connection Spacing
- ( ) 6 - NON-RESTRICTIVE w/1320 ft. Signal Spacing
- ( ) 7 - BOTH MEDIAN TYPES

CRITERIA

- (X) NEW CONSTRUCTION / RECONSTRUCTION
- ( ) RESURFACING (LA FACILITIES)
- ( ) RRR (ARTERIALS & COLLECTORS)

POTENTIAL EXCEPTIONS AND VARIATIONS RELATED TO TYPICAL SECTION:

**TYPICAL SECTION No. 15**



**RAMP C3 OVER EB I-4**

**TRAFFIC DATA**

Current Yr. - N/A AADT = N/A  
 Opening Yr. Est. - 2030 AADT = N/A  
 Design Yr. Est. - 2050 AADT = 3,400  
 Design Speed = 50 MPH  
 K = 10.5%  
 D = 64.8%  
 T = 13.3%  
 Design Hour  
 T = 7.0%

**NOT TO SCALE**

FINANCIAL PROJECT ID	SHEET NO.
446581-1-22-01	18

THE OFFICIAL RECORD OF THIS SHEET IS THE ELECTRONIC FILE DIGITALLY SIGNED AND SEALED UNDER RULE 61G15-23.004, F.A.C.



**PROJECT CONTROLS**

**CONTEXT CLASSIFICATION**

- ( ) C1 : NATURAL            ( ) C3C : SUBURBAN COMM.
- ( ) C2 : RURAL            ( ) C4 : URBAN GENERAL
- ( ) C2T : RURAL TOWN    ( ) C5 : URBAN CENTER
- ( ) C3R : SUBURBAN RES. ( ) C6 : URBAN CORE
- (X) N/A : L.A. FACILITY

**FUNCTIONAL CLASSIFICATION**

- ( ) INTERSTATE            ( ) MAJOR COLLECTOR
- (X) FREEWAY/EXPWY.    ( ) MINOR COLLECTOR
- ( ) PRINCIPAL ARTERIAL   ( ) LOCAL
- ( ) MINOR ARTERIAL

**HIGHWAY SYSTEM**

- (X) NATIONAL HIGHWAY SYSTEM
- (X) STRATEGIC INTERMODAL SYSTEM
- (X) STATE HIGHWAY SYSTEM
- ( ) OFF-STATE HIGHWAY SYSTEM

**ACCESS CLASSIFICATION**

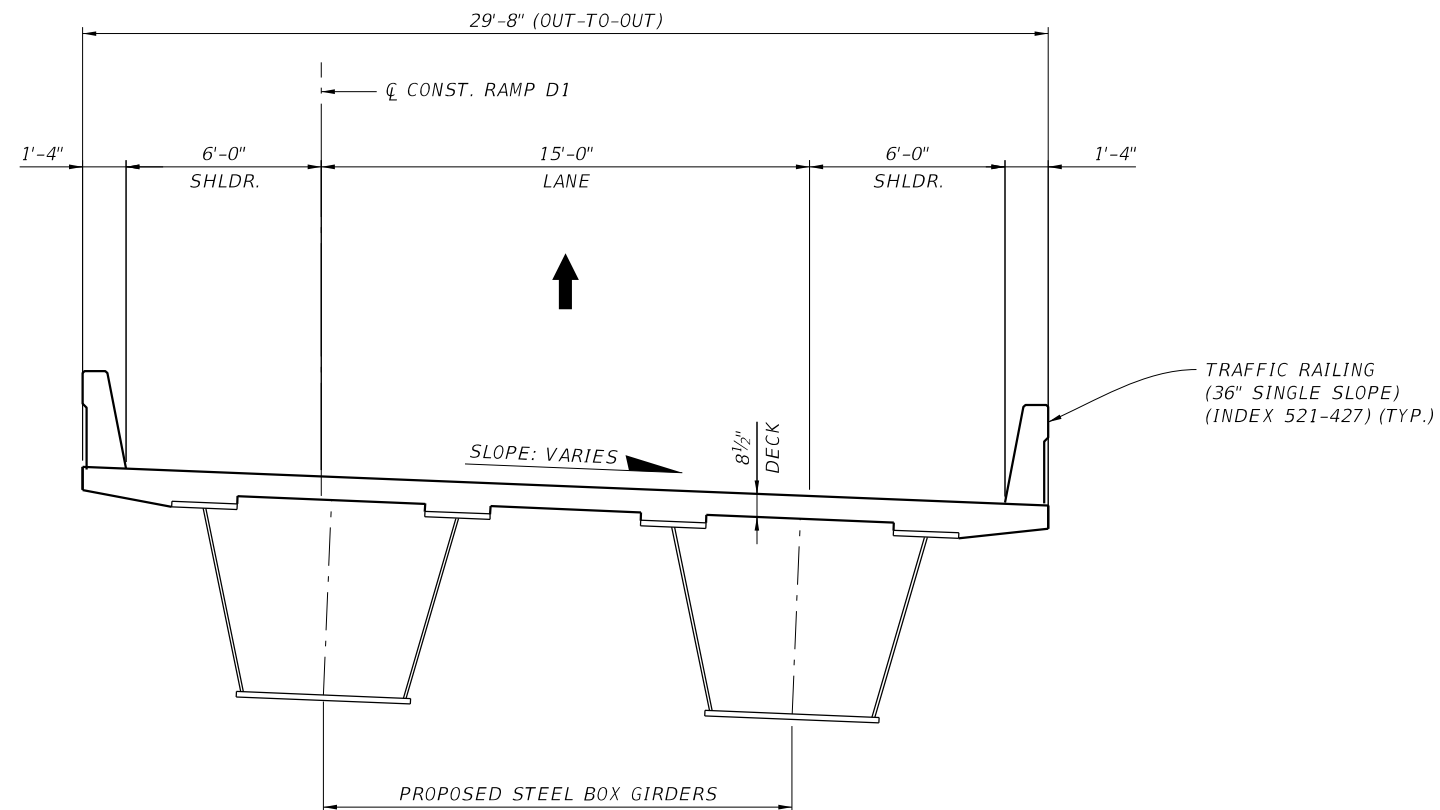
- (X) 1 - FREEWAY
- ( ) 2 - RESTRICTIVE w/Service Roads
- ( ) 3 - RESTRICTIVE w/660 ft. Connection Spacing
- ( ) 4 - NON-RESTRICTIVE w/2640 ft. Signal Spacing
- ( ) 5 - RESTRICTIVE w/440 ft. Connection Spacing
- ( ) 6 - NON-RESTRICTIVE w/1320 ft. Signal Spacing
- ( ) 7 - BOTH MEDIAN TYPES

**CRITERIA**

- (X) NEW CONSTRUCTION / RECONSTRUCTION
- ( ) RESURFACING (LA FACILITIES)
- ( ) RRR (ARTERIALS & COLLECTORS)

**POTENTIAL EXCEPTIONS AND VARIATIONS RELATED TO TYPICAL SECTION:**

**TYPICAL SECTION No. 16**



**RAMP D1 OVER WB I-4**

**TRAFFIC DATA**

Current Yr. - N/A AADT = N/A  
 Opening Yr. Est. - 2030 AADT = N/A  
 Design Yr. Est. - 2050 AADT = 3,400  
 Design Speed = 50 MPH  
 K = 10.5%  
 D = 64.8%  
 T = 13.3%  
 Design Hour  
 T = 7.0%

**NOT TO SCALE**

FINANCIAL PROJECT ID	SHEET NO.
446581-1-22-01	19

THE OFFICIAL RECORD OF THIS SHEET IS THE ELECTRONIC FILE DIGITALLY SIGNED AND SEALED UNDER RULE 61G15-23.004, F.A.C.

**PROJECT CONTROLS**

**CONTEXT CLASSIFICATION**

- ( ) C1 : NATURAL            ( ) C3C : SUBURBAN COMM.
- ( ) C2 : RURAL            ( ) C4 : URBAN GENERAL
- ( ) C2T : RURAL TOWN    ( ) C5 : URBAN CENTER
- ( ) C3R : SUBURBAN RES. ( ) C6 : URBAN CORE
- (X) N/A : L.A. FACILITY

**FUNCTIONAL CLASSIFICATION**

- ( ) INTERSTATE            ( ) MAJOR COLLECTOR
- (X) FREEWAY/EXPWY.    ( ) MINOR COLLECTOR
- ( ) PRINCIPAL ARTERIAL   ( ) LOCAL
- ( ) MINOR ARTERIAL

**HIGHWAY SYSTEM**

- (X) NATIONAL HIGHWAY SYSTEM
- (X) STRATEGIC INTERMODAL SYSTEM
- (X) STATE HIGHWAY SYSTEM
- ( ) OFF-STATE HIGHWAY SYSTEM

**ACCESS CLASSIFICATION**

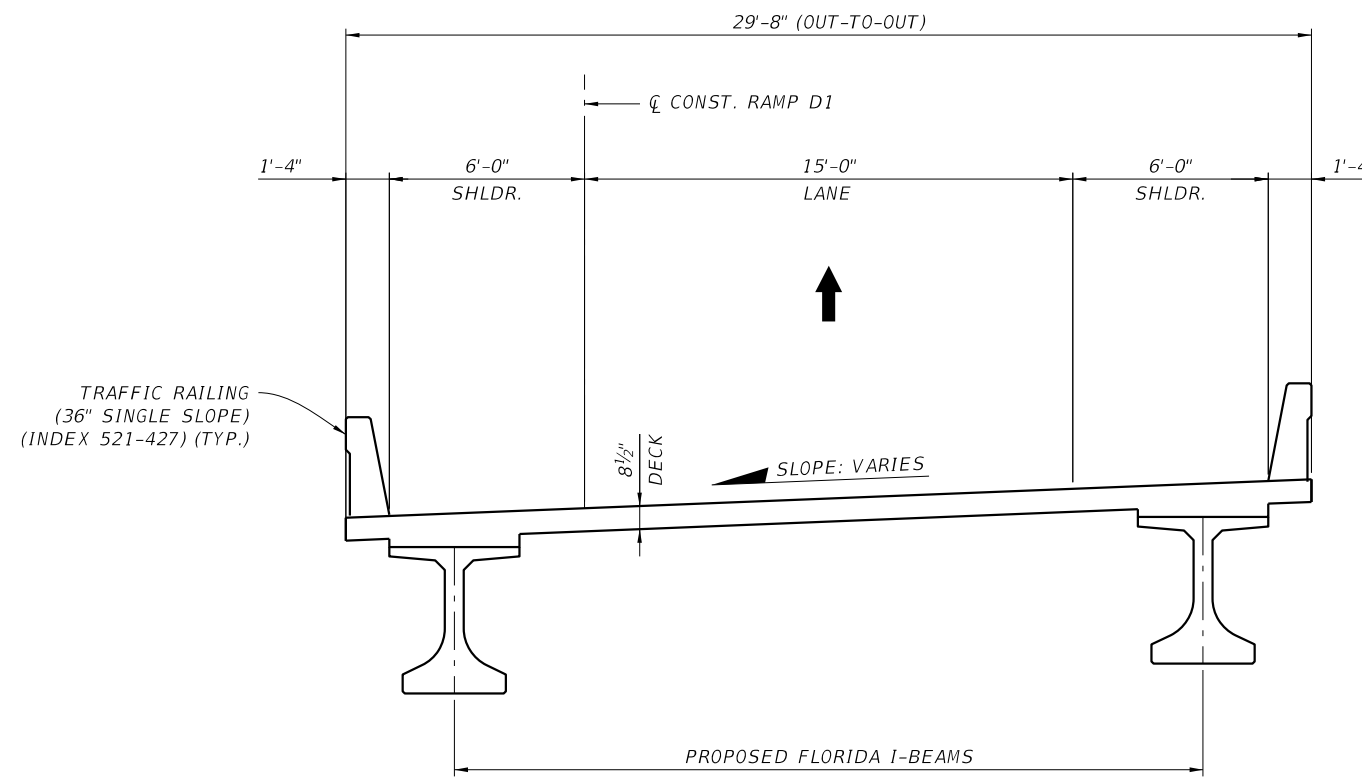
- (X) 1 - FREEWAY
- ( ) 2 - RESTRICTIVE w/Service Roads
- ( ) 3 - RESTRICTIVE w/660 ft. Connection Spacing
- ( ) 4 - NON-RESTRICTIVE w/2640 ft. Signal Spacing
- ( ) 5 - RESTRICTIVE w/440 ft. Connection Spacing
- ( ) 6 - NON-RESTRICTIVE w/1320 ft. Signal Spacing
- ( ) 7 - BOTH MEDIAN TYPES

**CRITERIA**

- (X) NEW CONSTRUCTION / RECONSTRUCTION
- ( ) RESURFACING (LA FACILITIES)
- ( ) RRR (ARTERIALS & COLLECTORS)

**POTENTIAL EXCEPTIONS AND VARIATIONS RELATED TO TYPICAL SECTION:**

**TYPICAL SECTION No. 17**



**RAMP D1 OVER POND**

**TRAFFIC DATA**

Current Yr. - N/A AADT = N/A  
 Opening Yr. Est. - 2030 AADT = N/A  
 Design Yr. Est. - 2050 AADT = 3,400  
 Design Speed = 50 MPH  
 K = 10.5%  
 D = 64.8%  
 T = 13.3%  
 Design Hour  
 T = 7.0%

**NOT TO SCALE**

FINANCIAL PROJECT ID	SHEET NO.
446581-1-22-01	20

**PROJECT CONTROLS**

**CONTEXT CLASSIFICATION**

- ( ) C1 : NATURAL                      ( ) C3C : SUBURBAN COMM.
- ( ) C2 : RURAL                        ( ) C4 : URBAN GENERAL
- ( ) C2T : RURAL TOWN               ( ) C5 : URBAN CENTER
- ( ) C3R : SUBURBAN RES.           ( ) C6 : URBAN CORE
- (X) N/A : L.A. FACILITY

**FUNCTIONAL CLASSIFICATION**

- ( ) INTERSTATE                      ( ) MAJOR COLLECTOR
- (X) FREEWAY/EXPWY.                ( ) MINOR COLLECTOR
- ( ) PRINCIPAL ARTERIAL            ( ) LOCAL
- ( ) MINOR ARTERIAL

**HIGHWAY SYSTEM**

- (X) NATIONAL HIGHWAY SYSTEM
- (X) STRATEGIC INTERMODAL SYSTEM
- (X) STATE HIGHWAY SYSTEM
- ( ) OFF-STATE HIGHWAY SYSTEM

**ACCESS CLASSIFICATION**

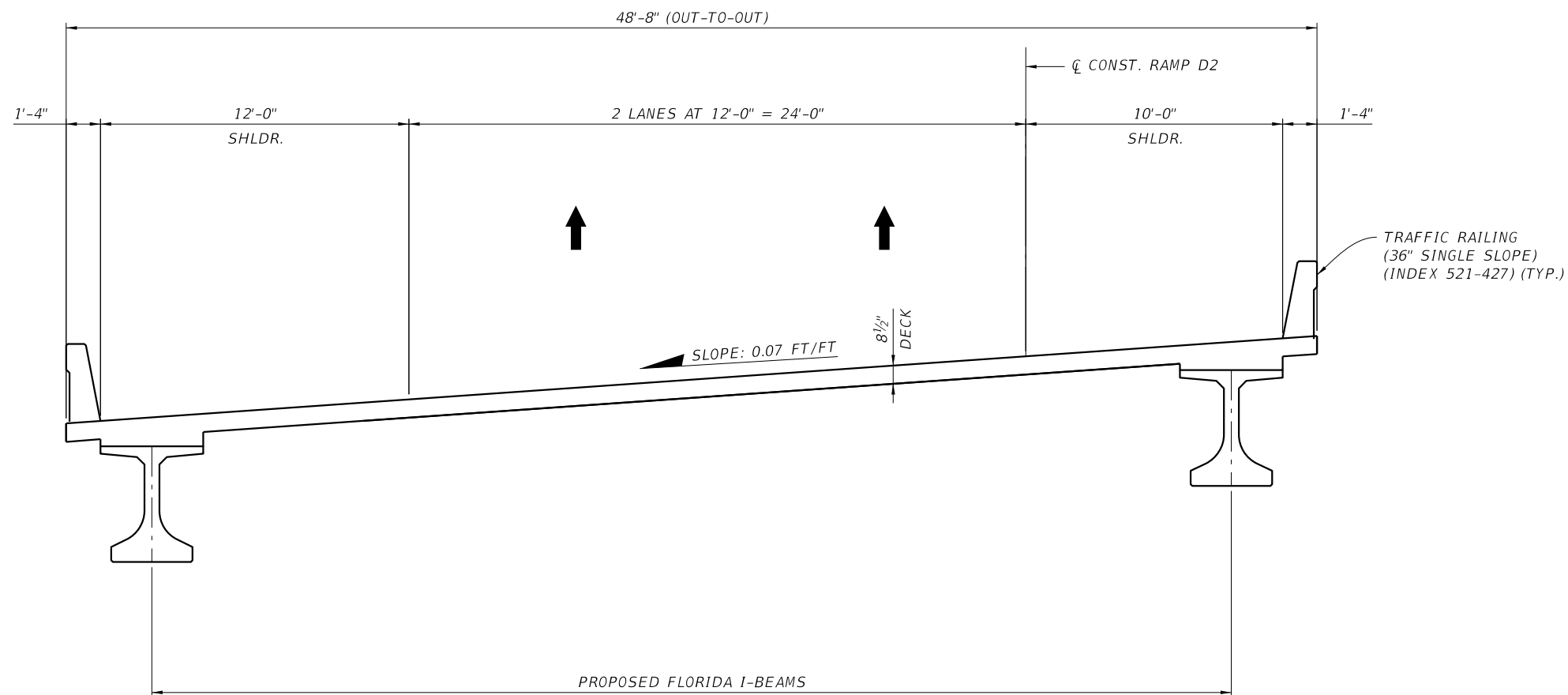
- (X) 1 - FREEWAY
- ( ) 2 - RESTRICTIVE w/Service Roads
- ( ) 3 - RESTRICTIVE w/660 ft. Connection Spacing
- ( ) 4 - NON-RESTRICTIVE w/2640 ft. Signal Spacing
- ( ) 5 - RESTRICTIVE w/440 ft. Connection Spacing
- ( ) 6 - NON-RESTRICTIVE w/1320 ft. Signal Spacing
- ( ) 7 - BOTH MEDIAN TYPES

**CRITERIA**

- (X) NEW CONSTRUCTION / RECONSTRUCTION
- ( ) RESURFACING (LA FACILITIES)
- ( ) RRR (ARTERIALS & COLLECTORS)

**POTENTIAL EXCEPTIONS AND VARIATIONS RELATED TO TYPICAL SECTION:**

**TYPICAL SECTION No. 18**



**RAMP D2 OVER DAVENPORT CREEK**

**TRAFFIC DATA**

Current Yr. - N/A AADT = N/A  
 Opening Yr. Est. - 2030 AADT = 7,600  
 Design Yr. Est. - 2050 AADT = 12,700  
 Design Speed = 50 MPH  
 K = 10.5%  
 D = 64.8%  
 T = 13.3%  
 Design Hour  
 T = 7.0%

**NOT TO SCALE**

FINANCIAL PROJECT ID	SHEET NO.
446581-1-22-01	21

THE OFFICIAL RECORD OF THIS SHEET IS THE ELECTRONIC FILE DIGITALLY SIGNED AND SEALED UNDER RULE 61G15-23.004, F.A.C.

**PROJECT CONTROLS**

**CONTEXT CLASSIFICATION**

- ( ) C1 : NATURAL            ( ) C3C : SUBURBAN COMM.
- ( ) C2 : RURAL            ( ) C4 : URBAN GENERAL
- ( ) C2T : RURAL TOWN    ( ) C5 : URBAN CENTER
- ( ) C3R : SUBURBAN RES. ( ) C6 : URBAN CORE
- (X) N/A : L.A. FACILITY

**FUNCTIONAL CLASSIFICATION**

- ( ) INTERSTATE            ( ) MAJOR COLLECTOR
- (X) FREEWAY/EXPWY.    ( ) MINOR COLLECTOR
- ( ) PRINCIPAL ARTERIAL   ( ) LOCAL
- ( ) MINOR ARTERIAL

**HIGHWAY SYSTEM**

- (X) NATIONAL HIGHWAY SYSTEM
- (X) STRATEGIC INTERMODAL SYSTEM
- (X) STATE HIGHWAY SYSTEM
- ( ) OFF-STATE HIGHWAY SYSTEM

**ACCESS CLASSIFICATION**

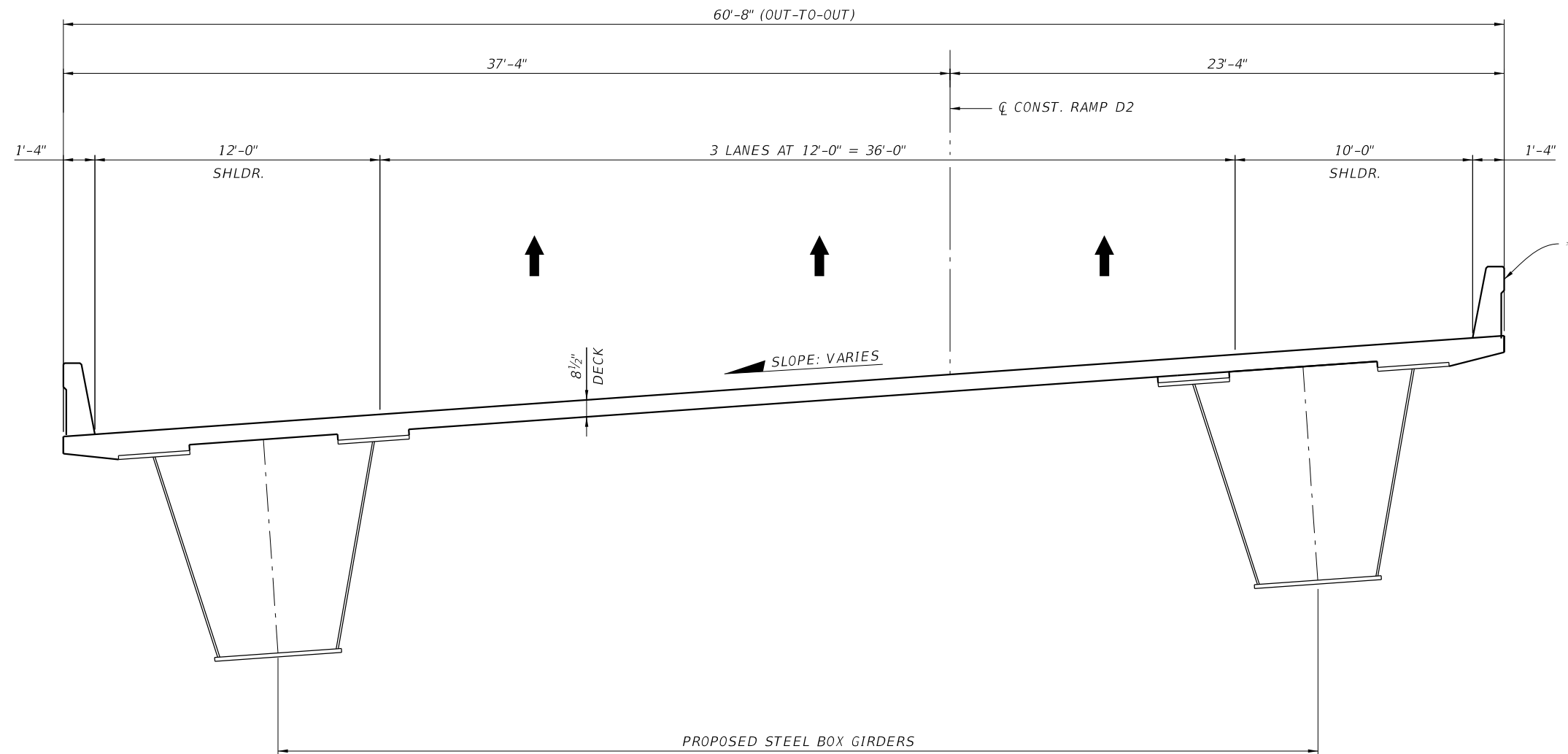
- (X) 1 - FREEWAY
- ( ) 2 - RESTRICTIVE w/Service Roads
- ( ) 3 - RESTRICTIVE w/660 ft. Connection Spacing
- ( ) 4 - NON-RESTRICTIVE w/2640 ft. Signal Spacing
- ( ) 5 - RESTRICTIVE w/440 ft. Connection Spacing
- ( ) 6 - NON-RESTRICTIVE w/1320 ft. Signal Spacing
- ( ) 7 - BOTH MEDIAN TYPES

**CRITERIA**

- (X) NEW CONSTRUCTION / RECONSTRUCTION
- ( ) RESURFACING (LA FACILITIES)
- ( ) RRR (ARTERIALS & COLLECTORS)

**POTENTIAL EXCEPTIONS AND VARIATIONS RELATED TO TYPICAL SECTION:**

**TYPICAL SECTION No. 19**



**RAMP D2 OVER I-4**

**TRAFFIC DATA**

Current Yr. - N/A AADT = N/A  
 Opening Yr. Est. - 2030 AADT = 7,600  
 Design Yr. Est. - 2050 AADT = 12,700  
 Design Speed = 50 MPH  
 K = 10.5%  
 D = 64.8%  
 T = 13.3%  
 Design Hour  
 T = 7.0%

\* TRAFFIC RAILING  
 (36" SINGLE SLOPE)  
 (INDEX 521-427) (TYP.)

**NOT TO SCALE**

FINANCIAL PROJECT ID	SHEET NO.
446581-1-22-01	22

THE OFFICIAL RECORD OF THIS SHEET IS THE ELECTRONIC FILE DIGITALLY SIGNED AND SEALED UNDER RULE 61G15-23.004, F.A.C.

**PROJECT CONTROLS**

**CONTEXT CLASSIFICATION**

- ( ) C1 : NATURAL                      ( ) C3C : SUBURBAN COMM.
- ( ) C2 : RURAL                        ( ) C4 : URBAN GENERAL
- ( ) C2T : RURAL TOWN                ( ) C5 : URBAN CENTER
- ( ) C3R : SUBURBAN RES.            ( ) C6 : URBAN CORE
- (X) N/A : L.A. FACILITY

**FUNCTIONAL CLASSIFICATION**

- ( ) INTERSTATE                        ( ) MAJOR COLLECTOR
- (X) FREEWAY/EXPWY.                ( ) MINOR COLLECTOR
- ( ) PRINCIPAL ARTERIAL              ( ) LOCAL
- ( ) MINOR ARTERIAL

**HIGHWAY SYSTEM**

- (X) NATIONAL HIGHWAY SYSTEM
- (X) STRATEGIC INTERMODAL SYSTEM
- (X) STATE HIGHWAY SYSTEM
- ( ) OFF-STATE HIGHWAY SYSTEM

**ACCESS CLASSIFICATION**

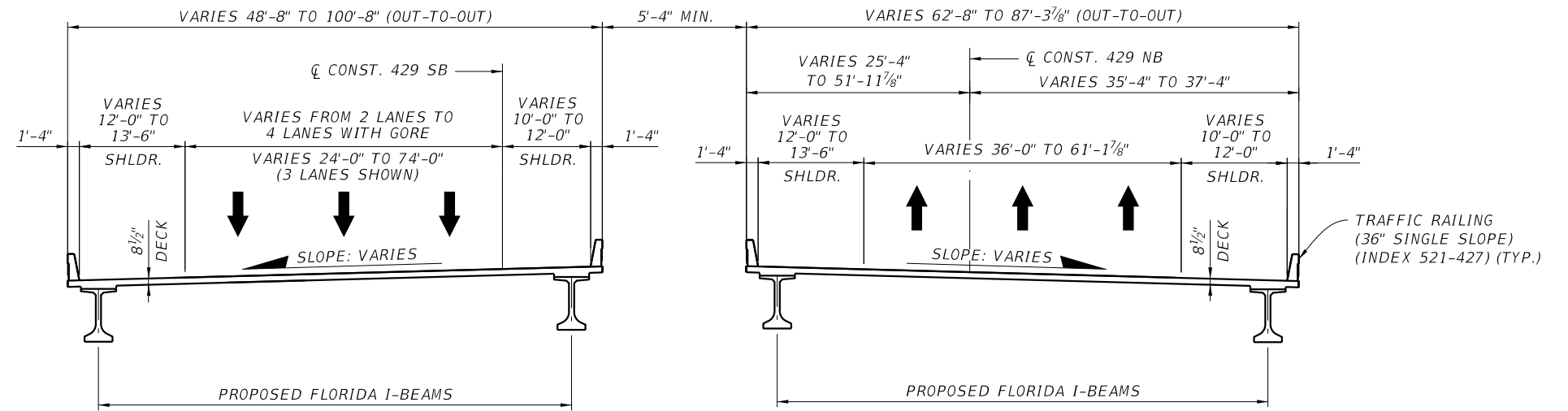
- (X) 1 - FREEWAY
- ( ) 2 - RESTRICTIVE w/Service Roads
- ( ) 3 - RESTRICTIVE w/660 ft. Connection Spacing
- ( ) 4 - NON-RESTRICTIVE w/2640 ft. Signal Spacing
- ( ) 5 - RESTRICTIVE w/440 ft. Connection Spacing
- ( ) 6 - NON-RESTRICTIVE w/1320 ft. Signal Spacing
- ( ) 7 - BOTH MEDIAN TYPES

**CRITERIA**

- (X) NEW CONSTRUCTION / RECONSTRUCTION
- ( ) RESURFACING (LA FACILITIES)
- ( ) RRR (ARTERIALS & COLLECTORS)

**POTENTIAL EXCEPTIONS AND VARIATIONS RELATED TO TYPICAL SECTION:**

**TYPICAL SECTION No. 20**



**SR 538 OVER DAVENPORT CREEK**

**TRAFFIC DATA**  
 Current Yr. - N/A AADT = N/A  
 Opening Yr. Est. - 2030 AADT = 12,000  
 Design Yr. Est. - 2050 AADT = 23,000  
 Design Speed = 70 MPH  
 K = 11.0%  
 D = 60.0%  
 T = 12.8%  
 Design Hour  
 T = 7.0%

**NOT TO SCALE**

FINANCIAL PROJECT ID	SHEET NO.
446581-1-22-01	23

THE OFFICIAL RECORD OF THIS SHEET IS THE ELECTRONIC FILE DIGITALLY SIGNED AND SEALED UNDER RULE 61G15-23.004, F.A.C.



**PROJECT CONTROLS**

**CONTEXT CLASSIFICATION**

- ( ) C1 : NATURAL            ( ) C3C : SUBURBAN COMM.
- ( ) C2 : RURAL            ( ) C4 : URBAN GENERAL
- ( ) C2T : RURAL TOWN    ( ) C5 : URBAN CENTER
- ( ) C3R : SUBURBAN RES. ( ) C6 : URBAN CORE
- (X) N/A : L.A. FACILITY

**FUNCTIONAL CLASSIFICATION**

- ( ) INTERSTATE            ( ) MAJOR COLLECTOR
- (X) FREEWAY/EXPWY.    ( ) MINOR COLLECTOR
- ( ) PRINCIPAL ARTERIAL   ( ) LOCAL
- ( ) MINOR ARTERIAL

**HIGHWAY SYSTEM**

- (X) NATIONAL HIGHWAY SYSTEM
- (X) STRATEGIC INTERMODAL SYSTEM
- (X) STATE HIGHWAY SYSTEM
- ( ) OFF-STATE HIGHWAY SYSTEM

**ACCESS CLASSIFICATION**

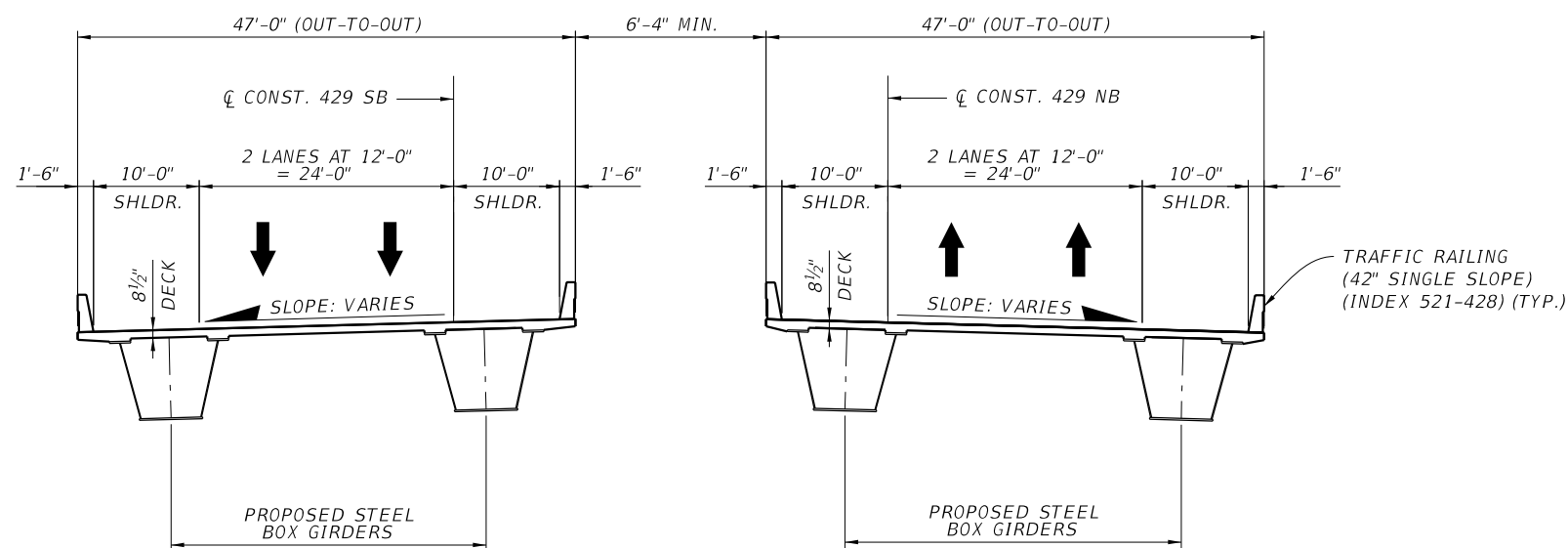
- (X) 1 - FREEWAY
- ( ) 2 - RESTRICTIVE w/Service Roads
- ( ) 3 - RESTRICTIVE w/660 ft. Connection Spacing
- ( ) 4 - NON-RESTRICTIVE w/2640 ft. Signal Spacing
- ( ) 5 - RESTRICTIVE w/440 ft. Connection Spacing
- ( ) 6 - NON-RESTRICTIVE w/1320 ft. Signal Spacing
- ( ) 7 - BOTH MEDIAN TYPES

**CRITERIA**

- (X) NEW CONSTRUCTION / RECONSTRUCTION
- ( ) RESURFACING (LA FACILITIES)
- ( ) RRR (ARTERIALS & COLLECTORS)

**POTENTIAL EXCEPTIONS AND VARIATIONS RELATED TO TYPICAL SECTION:**

**TYPICAL SECTION No. 21**



SR 538 OVER I-4

**TRAFFIC DATA**

Current Yr. - N/A AADT = N/A  
 Opening Yr. Est. - 2030 AADT = 24,000  
 Design Yr. Est. - 2050 AADT = 46,000  
 Design Speed = 70 MPH  
 K = 11.0%  
 D = 60.0%  
 T = 12.8%  
 Design Hour  
 T = 7.0%

NOT TO SCALE

FINANCIAL PROJECT ID	SHEET NO.
446581-1-22-01	24

THE OFFICIAL RECORD OF THIS SHEET IS THE ELECTRONIC FILE DIGITALLY SIGNED AND SEALED UNDER RULE 61G15-23.004, F.A.C.

**PROJECT CONTROLS**

**CONTEXT CLASSIFICATION**

- ( ) C1 : NATURAL                      ( ) C3C : SUBURBAN COMM.
- ( ) C2 : RURAL                        ( ) C4 : URBAN GENERAL
- ( ) C2T : RURAL TOWN                ( ) C5 : URBAN CENTER
- ( ) C3R : SUBURBAN RES.            ( ) C6 : URBAN CORE
- (X) N/A : L.A. FACILITY

**FUNCTIONAL CLASSIFICATION**

- ( ) INTERSTATE                        ( ) MAJOR COLLECTOR
- (X) FREEWAY/EXPWY.                ( ) MINOR COLLECTOR
- ( ) PRINCIPAL ARTERIAL              ( ) LOCAL
- ( ) MINOR ARTERIAL

**HIGHWAY SYSTEM**

- (X) NATIONAL HIGHWAY SYSTEM
- (X) STRATEGIC INTERMODAL SYSTEM
- (X) STATE HIGHWAY SYSTEM
- ( ) OFF-STATE HIGHWAY SYSTEM

**ACCESS CLASSIFICATION**

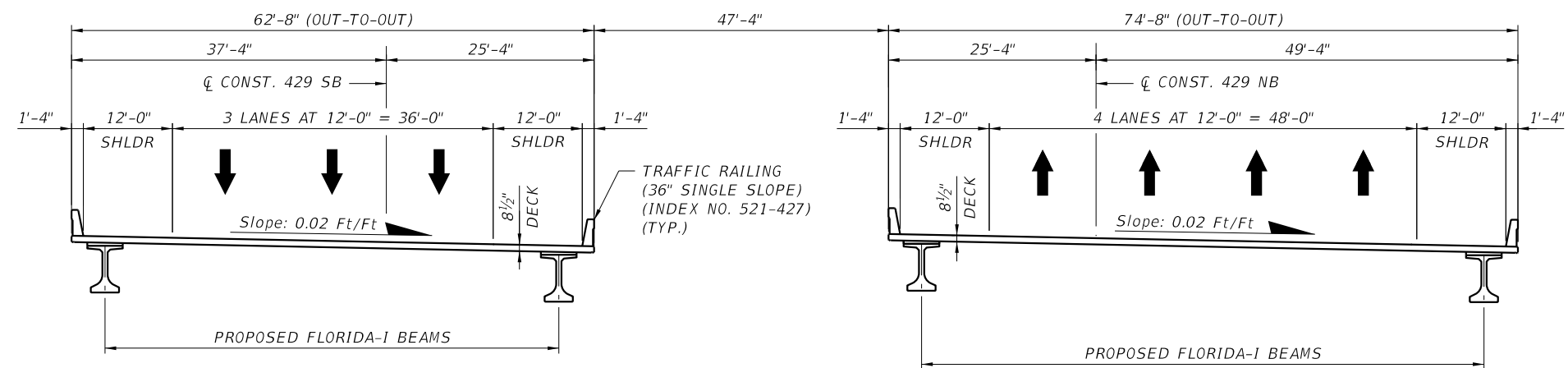
- (X) 1 - FREEWAY
- ( ) 2 - RESTRICTIVE w/Service Roads
- ( ) 3 - RESTRICTIVE w/660 ft. Connection Spacing
- ( ) 4 - NON-RESTRICTIVE w/2640 ft. Signal Spacing
- ( ) 5 - RESTRICTIVE w/440 ft. Connection Spacing
- ( ) 6 - NON-RESTRICTIVE w/1320 ft. Signal Spacing
- ( ) 7 - BOTH MEDIAN TYPES

**CRITERIA**

- (X) NEW CONSTRUCTION / RECONSTRUCTION
- ( ) RESURFACING (LA FACILITIES)
- ( ) RRR (ARTERIALS & COLLECTORS)

**POTENTIAL EXCEPTIONS AND VARIATIONS RELATED TO TYPICAL SECTION:**

**TYPICAL SECTION No. 22**



SR 538 OVER CR 532

**TRAFFIC DATA**

Current Yr. - N/A AADT = N/A  
 Opening Yr. Est. - 2030 AADT = 15,600  
 Design Yr. Est. - 2050 AADT = 31,800  
 Design Speed = 70 MPH  
 K = 11.0%  
 D = 60.0%  
 T = 12.8%  
 Design Hour  
 T = 7.0%

NOT TO SCALE

FINANCIAL PROJECT ID	SHEET NO.
446581-1-22-01	25

THE OFFICIAL RECORD OF THIS SHEET IS THE ELECTRONIC FILE DIGITALLY SIGNED AND SEALED UNDER RULE 61G15-23.004, F.A.C.

**PROJECT CONTROLS**

**CONTEXT CLASSIFICATION**

- ( ) C1 : NATURAL                      ( ) C3C : SUBURBAN COMM.
- ( ) C2 : RURAL                        ( ) C4 : URBAN GENERAL
- ( ) C2T : RURAL TOWN                ( ) C5 : URBAN CENTER
- ( ) C3R : SUBURBAN RES.            ( ) C6 : URBAN CORE
- (X) N/A : L.A. FACILITY

**FUNCTIONAL CLASSIFICATION**

- ( ) INTERSTATE                        ( ) MAJOR COLLECTOR
- (X) FREEWAY/EXPWY.                ( ) MINOR COLLECTOR
- ( ) PRINCIPAL ARTERIAL            ( ) LOCAL
- ( ) MINOR ARTERIAL

**HIGHWAY SYSTEM**

- (X) NATIONAL HIGHWAY SYSTEM
- (X) STRATEGIC INTERMODAL SYSTEM
- (X) STATE HIGHWAY SYSTEM
- ( ) OFF-STATE HIGHWAY SYSTEM

**ACCESS CLASSIFICATION**

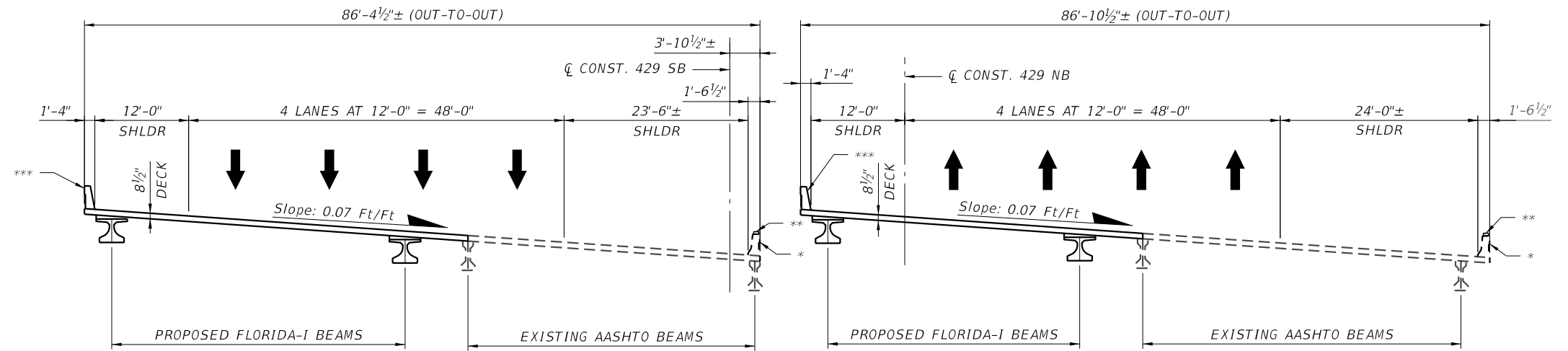
- (X) 1 - FREEWAY
- ( ) 2 - RESTRICTIVE w/Service Roads
- ( ) 3 - RESTRICTIVE w/660 ft. Connection Spacing
- ( ) 4 - NON-RESTRICTIVE w/2640 ft. Signal Spacing
- ( ) 5 - RESTRICTIVE w/440 ft. Connection Spacing
- ( ) 6 - NON-RESTRICTIVE w/1320 ft. Signal Spacing
- ( ) 7 - BOTH MEDIAN TYPES

**CRITERIA**

- (X) NEW CONSTRUCTION / RECONSTRUCTION
- ( ) RESURFACING (LA FACILITIES)
- ( ) RRR (ARTERIALS & COLLECTORS)

**POTENTIAL EXCEPTIONS AND VARIATIONS RELATED TO TYPICAL SECTION:**

**TYPICAL SECTION No. 23**



- \* EXISTING 32" F-SHAPE TRAFFIC RAILING (TO REMAIN)
- \*\* TRAFFIC RAILING (RECTANGULAR TUBE RETROFIT) (INDEX 460-490)
- \*\*\* TRAFFIC RAILING (36" SINGLE SLOPE) (INDEX NO. 521-427)

**SR 429 OVER SAND HILL ROAD**

**TRAFFIC DATA**

Current Yr. - 2020 AADT = 33,300  
 Opening Yr. Est. - 2030 AADT = 50,800  
 Design Yr. Est. - 2050 AADT = 96,400  
 Design Speed = 70 MPH  
 K = 10.5%  
 D = 58.0%  
 T = 12.8%  
 Design Hour  
 T = 7.0%

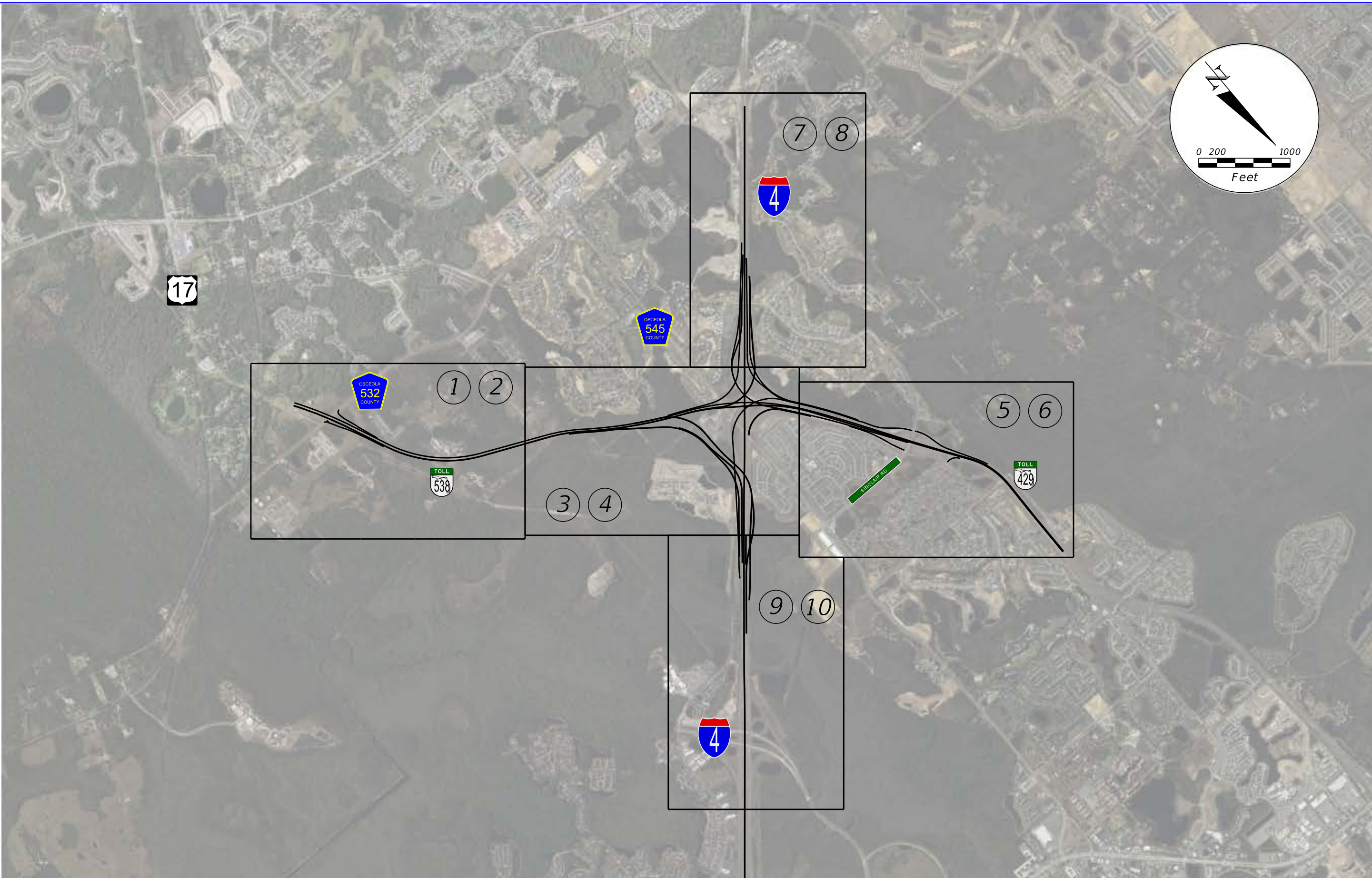
**NOT TO SCALE**

FINANCIAL PROJECT ID	SHEET NO.
446581-1-22-01	26

THE OFFICIAL RECORD OF THIS SHEET IS THE ELECTRONIC FILE DIGITALLY SIGNED AND SEALED UNDER RULE 61G15-23.004, F.A.C.

## APPENDIX C

### Preferred Alternative Concept

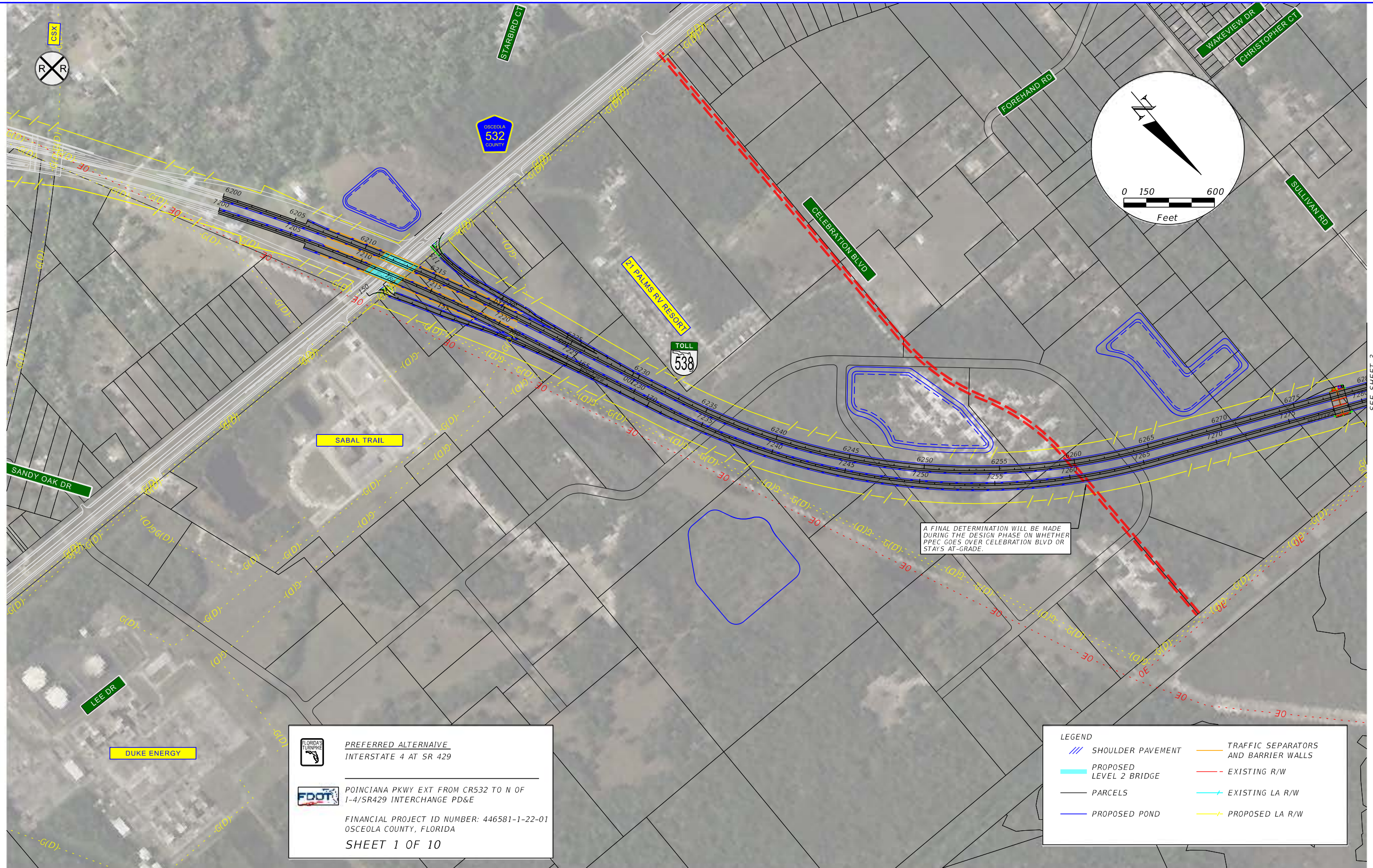



1/24/2023 9:41:19 PM Chris.Davidson  
 c:\pw\work\vrsh\_pw\pw\_user\0419471\PLAY RD01.dgn

REVISIONS		ENGINEER OF RECORD		STATE OF FLORIDA DEPARTMENT OF TRANSPORTATION			PROJECT LAYOUT	SHEET NO.
DATE	DESCRIPTION	DATE	DESCRIPTION	ROAD NO.	COUNTY	FINANCIAL PROJECT ID		
			RAMON F. BRETON LICENSE NUMBER: 53139 KIMLEY HORN AND ASSOCIATES, INC. 189 S ORANGE AVE. SUITE 1000, ORLANDO, FL 32801		OSCEOLA & POLK	446581-1-22-01		


FAC NOTE













 **PREFERRED ALTERNATIVE**  
 INTERSTATE 4 AT SR 429

---

 **POINCIANA PKWY EXT FROM CR532 TO N OF I-4/SR429 INTERCHANGE PD&E**

FINANCIAL PROJECT ID NUMBER: 446581-1-22-01  
 OSCEOLA COUNTY, FLORIDA  
**SHEET 1 OF 10**

LEGEND	
	SHOULDER PAVEMENT
	PROPOSED LEVEL 2 BRIDGE
	PARCELS
	PROPOSED POND
	TRAFFIC SEPARATORS AND BARRIER WALLS
	EXISTING R/W
	EXISTING LA R/W
	PROPOSED LA R/W

\$TIMES \$USERS \$DATE\$  
 c:\pw\work\vrsh\_pw\pw\_user\0419471\PLANRD\_2\_01New.dgn

REVISIONS	
DATE	DESCRIPTION

**ENGINEER OF RECORD**  
 RAMON F. BRETON  
 LICENSE NUMBER: 53139  
 KIMLEY HORN AND ASSOCIATES, INC.  
 189 S ORANGE AVE. SUITE 1000,  
 ORLANDO, FL 32801

STATE OF FLORIDA DEPARTMENT OF TRANSPORTATION		
ROAD NO.	COUNTY	FINANCIAL PROJECT ID
	OSCEOLA & POLK	446581-1-22-01

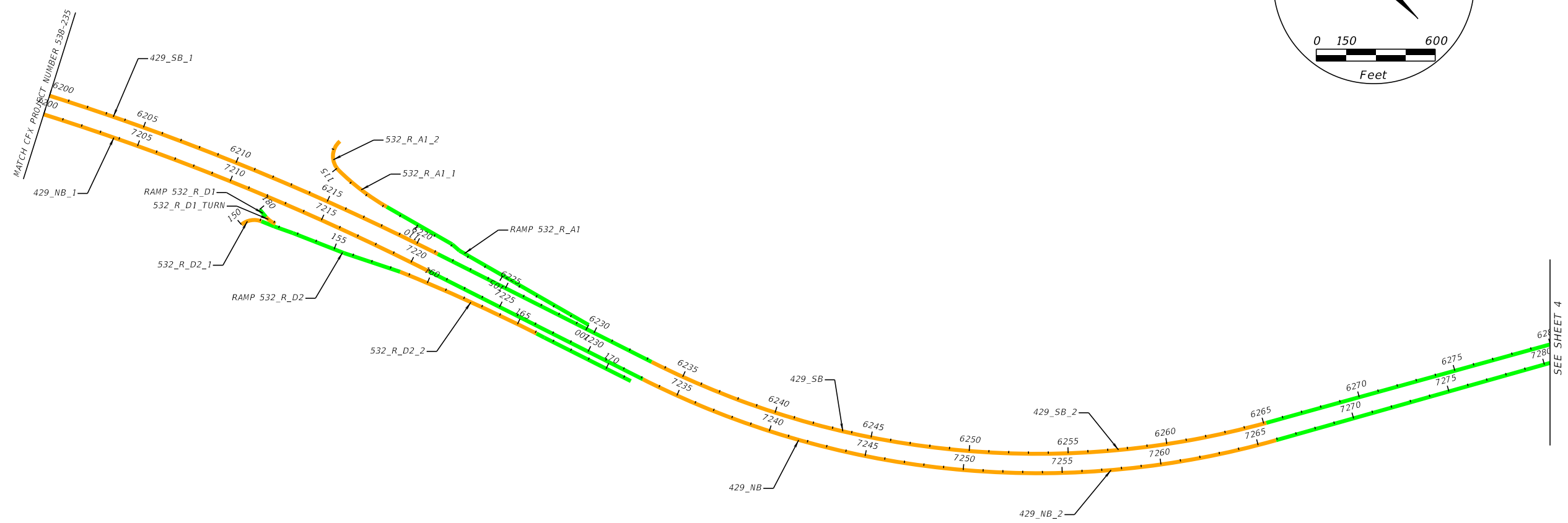
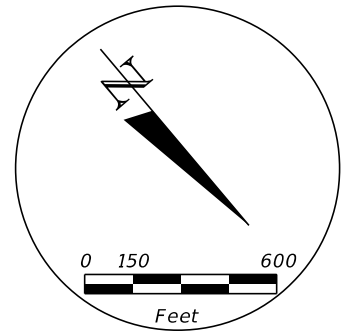
PLAN SHEET

SHEET NO.  
 1

SEE SHEET 3

FAC NOTE





<b>CURVE DATA 532_R_A1_1</b>	<b>CURVE DATA 532_R_A1_2</b>
PI STA. = 113+34.76	PI STA. = 113+95.05
Δ = 141°30'41" (RT)	Δ = 95°05'12" (RT)
D = 04°49'22"	D = 57°17'45"
T = 152.66	T = 109.30
L = 305.65	L = 165.96
R = 1.188.00	R = 100.00
PC STA. = 111+82.10	PC STA. = 114+85.76
PCC STA. = 114+85.76	PT STA. = 116+31.71

<b>CURVE DATA 532_R_D1_TURN</b>
PI STA. = 180+80.90
Δ = 29°15'39" (LT)
D = 49°49'21"
T = 30.02
L = 58.73
R = 135.00
PC STA. = 180+50.88
PT STA. = 181+09.61

<b>CURVE DATA 532_R_D2_1</b>	<b>CURVE DATA 532_R_D2_2</b>
PI STA. = 150+59.35	PI STA. = 162+30.01
Δ = 61°22'48" (RT)	Δ = 04°48'47" (RT)
D = 57°17'45"	D = 00°38'15"
T = 59.35	T = 377.74
L = 107.13	L = 755.03
R = 100.00	R = 0.988.00
PC STA. = 150+00.00	PC STA. = 158+52.27
PT STA. = 151+07.13	PT STA. = 166+07.30
e = 0.020	e = 0.020
D.S. = 50 mph	D.S. = 50 mph

<b>CURVE DATA 429_NB_1</b>	<b>CURVE DATA 429_NB_2</b>
PI STA. = 7210+53.05	PI STA. = 7250+31.99
Δ = 09°16'22" (RT)	Δ = 42°33'05" (LT)
D = 00°26'28"	D = 01°17'45"
T = 1.053.05	T = 1,721.91
L = 2,101.50	L = 3,204.06
R = 12,985.00	R = 4,422.00
PC STA. = 7200+00.00	PC STA. = 7233+10.08
PT STA. = 7221+01.50	PT STA. = 7265+04.14
e = 0.020	e = 0.048
D.S. = 70 mph	D.S. = 70 mph

<b>CURVE DATA 429_SB_1</b>	<b>CURVE DATA 429_SB_2</b>
PI STA. = 6210+61.09	PI STA. = 6249+96.11
Δ = 09°16'22" (RT)	Δ = 42°14'09" (LT)
D = 00°26'17"	D = 01°19'30"
T = 1,061.09	T = 1,670.05
L = 2,117.55	L = 3,187.46
R = 13,082.99	R = 4,324.00
PC STA. = 6200+00.00	PC STA. = 6233+26.06
PT STA. = 6221+17.55	PT STA. = 6265+13.52
e = 0.020	e = 0.049
D.S. = 70 mph	D.S. = 70 mph

<b>LEGEND</b>
DENOTES TANGENT SECTIONS
DENOTES CURVE SECTIONS

**FLORIDA'S TURNPIKE**

**PREFERRED ALTERNATIVE**  
INTERSTATE 4 AT SR 429

---

**FDOT** POINCIANA PKWY EXT FROM CR532 TO N OF I-4/SR429 INTERCHANGE PD&E

FINANCIAL PROJECT ID NUMBER: 446581-1-22-01  
OSCEOLA COUNTY, FLORIDA

**SHEET 2 OF 10**

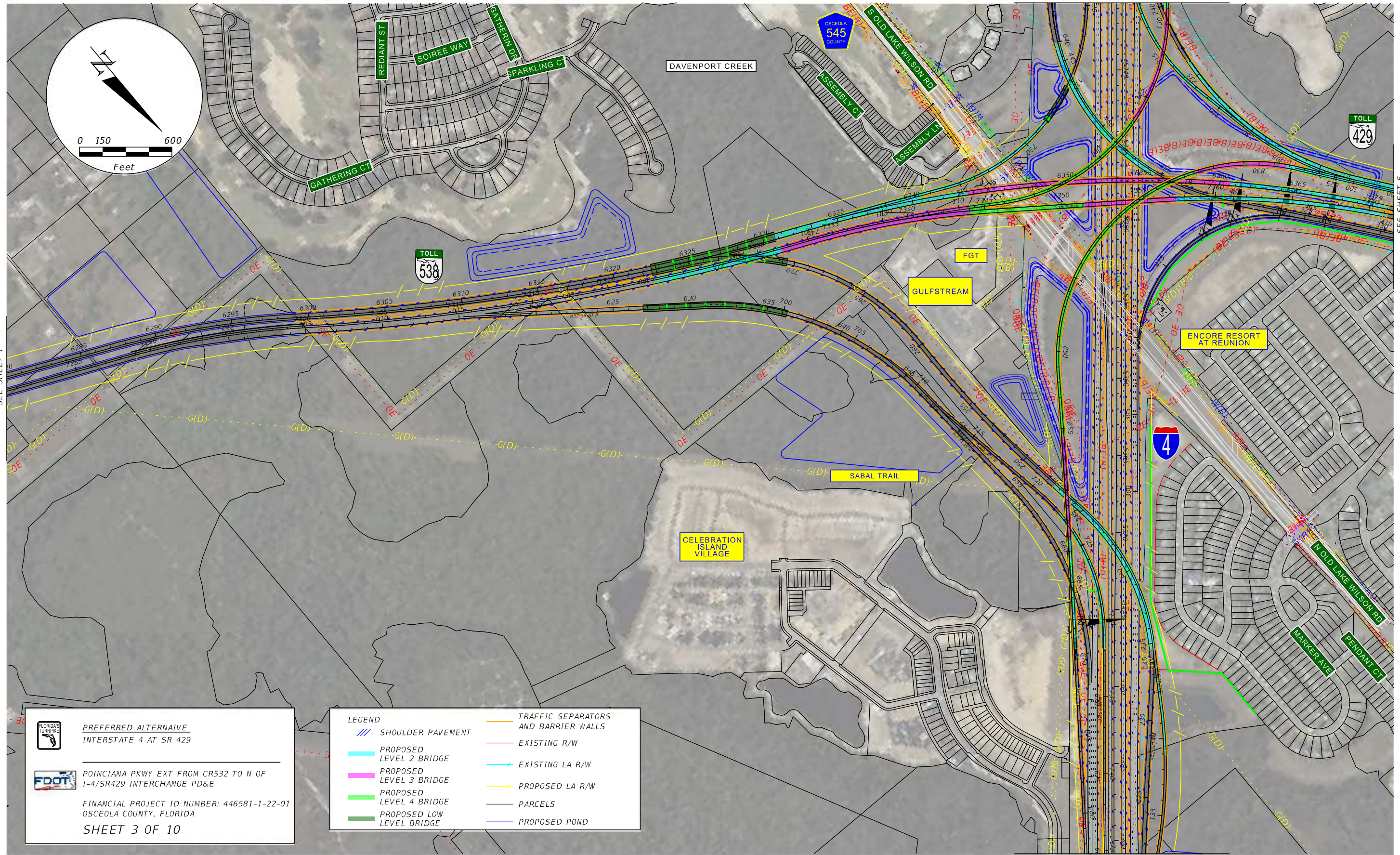
\$TIMES \$USERS  
 c:\pw\work\vrsh\_pw\user\user\0419471\PLANRD\_2\_02New.dgn

<b>REVISIONS</b>				<b>ENGINEER OF RECORD</b>		<b>STATE OF FLORIDA</b>		<b>ALIGNMENT SHEET</b>	<b>SHEET NO.</b> 2
<b>DATE</b>	<b>DESCRIPTION</b>	<b>DATE</b>	<b>DESCRIPTION</b>	RAMON F. BRETON LICENSE NUMBER: 53139 KIMLEY HORN AND ASSOCIATES, INC. 189 S ORANGE AVE. SUITE 1000, ORLANDO, FL 32801		<b>DEPARTMENT OF TRANSPORTATION</b>			
				<b>ROAD NO.</b>	<b>COUNTY</b>	<b>FINANCIAL PROJECT ID</b>			
					OSCEOLA & POLK	446581-1-22-01			

FAC NOTE



SEE SHEET 7



SEE SHEET 1

SEE SHEET 5

SEE SHEET 9

**PREFERRED ALTERNATIVE**  
 INTERSTATE 4 AT SR 429

**POINCIANA PKWY EXT FROM CR532 TO N OF I-4/SR429 INTERCHANGE PD&E**

FINANCIAL PROJECT ID NUMBER: 446581-1-22-01  
 OSCEOLA COUNTY, FLORIDA

**SHEET 3 OF 10**

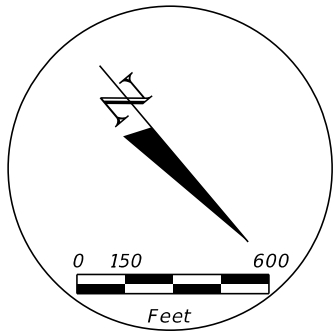
LEGEND	
	SHOULDER PAVEMENT
	PROPOSED LEVEL 2 BRIDGE
	PROPOSED LEVEL 3 BRIDGE
	PROPOSED LEVEL 4 BRIDGE
	PROPOSED LOW LEVEL BRIDGE
	TRAFFIC SEPARATORS AND BARRIER WALLS
	EXISTING R/W
	EXISTING LA R/W
	PROPOSED LA R/W
	PARCELS
	PROPOSED POND

\$DATE\$ \$TIME\$ \$USER\$ C:\pw\_work\vrsh\_pw\pw\_user\0419471\PLANRD\_2\_01New.dgn

REVISIONS		ENGINEER OF RECORD		STATE OF FLORIDA DEPARTMENT OF TRANSPORTATION			SHEET NO.
DATE	DESCRIPTION	DATE	DESCRIPTION	ROAD NO.	COUNTY	FINANCIAL PROJECT ID	
					OSCEOLA & POLK	446581-1-22-01	3
				<b>PLAN SHEET</b>			

FAC NOTE





**PREFERRED ALTERNATIVE**  
**INTERSTATE 4 AT SR 429**

**POINCIANA PKWY EXT FROM CR532 TO N OF I-4/SR429 INTERCHANGE PD&E**

FINANCIAL PROJECT ID NUMBER: 446581-1-22-01  
 OSCEOLA COUNTY, FLORIDA

**SHEET 4 OF 10**

**LEGEND**

— DENOTES TANGENT SECTIONS

— DENOTES CURVE SECTIONS

<b>CURVE DATA 429_NB_3</b> PI STA. = 7294+18.63 Δ = 12°26'45" (RT) D = 01'02'38" T = 1,192.11 L = 5,488.00 PC STA. = 7289+20.22 PCC STA. = 7300+12.33 e = 0.039 D.S. = 70 mph	<b>CURVE DATA 429_NB_4</b> PI STA. = 7316+80.94 Δ = 12°52'51" (LT) D = 00'23'15" T = 1,668.61 L = 3,323.16 PC STA. = 7300+12.33 PCC STA. = 7333+35.49 e = N/C D.S. = 70 mph	<b>CURVE DATA 429_NB_5</b> PI STA. = 7339+26.00 Δ = 12°23'42" (RT) D = 01'03'13" T = 590.51 L = 1,176.41 PC STA. = 7333+35.49 PCC STA. = 7345+11.90 e = 0.039 D.S. = 70 mph	<b>CURVE DATA 429_NB_6</b> PI STA. = 7366+45.77 Δ = 20°37'55" (RT) D = 01'00'26" T = 1,035.55 L = 2,048.67 PC STA. = 7356+10.21 PCC STA. = 7376+58.89 e = 0.037 D.S. = 70 mph
--	--	--	--

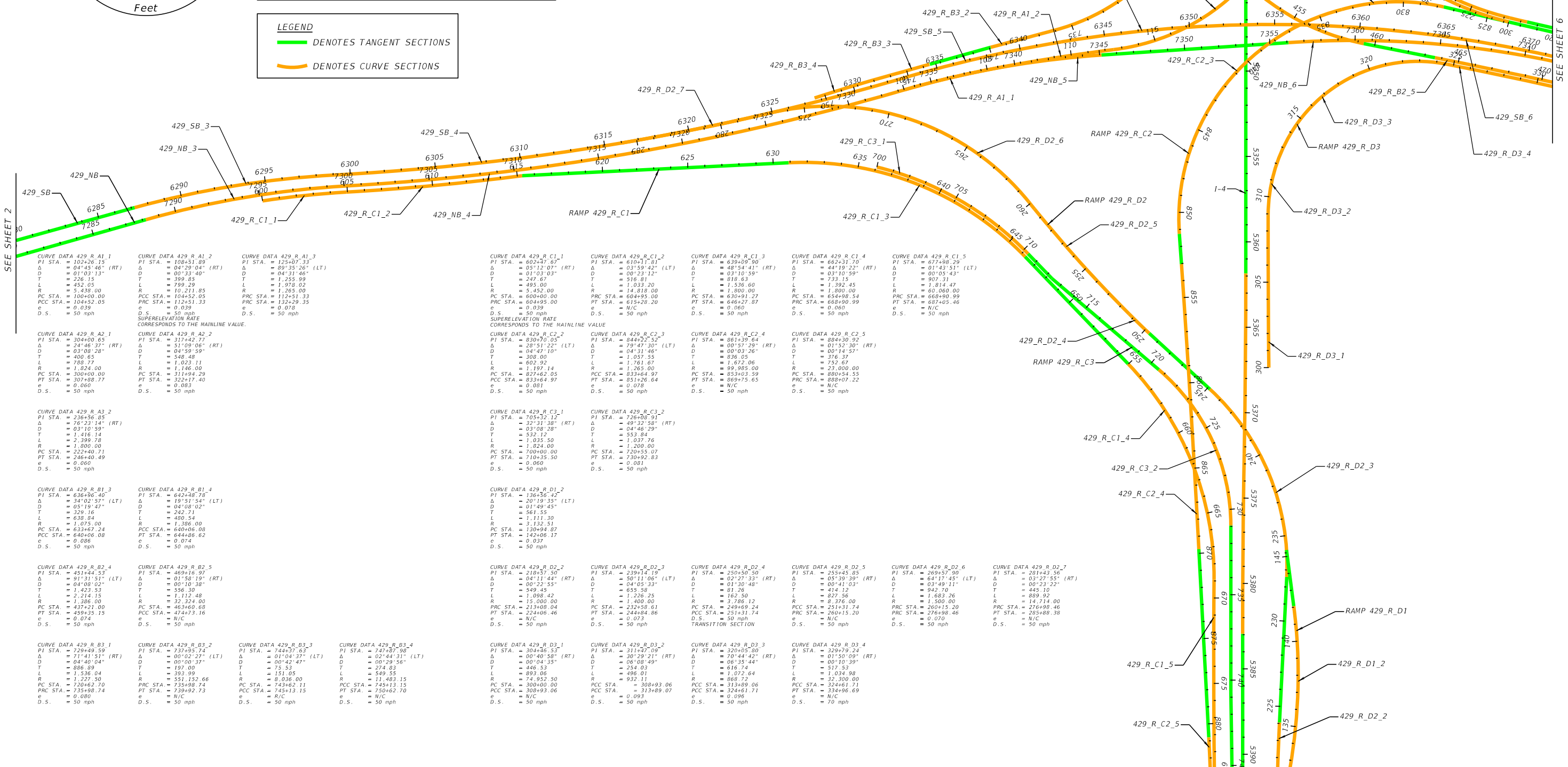
<b>CURVE DATA 429_SB_3</b> PI STA. = 6283+15.81 Δ = 12°22'55" (RT) D = 01'02'30" T = 596.61 L = 1,188.57 PC STA. = 6287+19.20 PCC STA. = 6299+07.77 e = 0.039 D.S. = 70 mph	<b>CURVE DATA 429_SB_4</b> PI STA. = 6316+10.35 Δ = 13°12'03" (LT) D = 00'23'22" T = 1,702.58 L = 3,390.08 PC STA. = 604+95.00 PCC STA. = 6324+97.85 e = 0.020 D.S. = 70 mph	<b>CURVE DATA 429_SB_5</b> PI STA. = 6337+11.27 Δ = 06°46'24" (RT) D = 00'42'58" T = 473.42 L = 945.73 PC STA. = 6332+97.85 PCC STA. = 6342+43.58 e = 0.027 D.S. = 70 mph	<b>CURVE DATA 429_SB_6</b> PI STA. = 6350+58.25 Δ = 24°30'37" (RT) D = 00'46'15" T = 1,614.67 L = 3,179.93 PC STA. = 6342+43.58 PCC STA. = 6374+23.51 e = 0.029 D.S. = 70 mph
--	---	--	--

<b>CURVE DATA 429_R_C1_1</b> PI STA. = 602+47.67 Δ = 05°12'07" (RT) D = 00'23'12" T = 247.67 L = 495.00 PC STA. = 600+00.00 PCC STA. = 604+95.00 e = 0.039 D.S. = 50 mph	<b>CURVE DATA 429_R_C1_2</b> PI STA. = 610+11.81 Δ = 02°59'42" (LT) D = 00'23'12" T = 516.81 L = 1,033.20 PC STA. = 604+95.00 PCC STA. = 604+95.00 e = N/C D.S. = 50 mph	<b>CURVE DATA 429_R_C1_3</b> PI STA. = 639+09.90 Δ = 48°54'41" (RT) D = 03'10'59" T = 818.63 L = 1,536.60 PC STA. = 630+91.27 PCC STA. = 646+27.87 e = 0.060 D.S. = 50 mph	<b>CURVE DATA 429_R_C1_4</b> PI STA. = 662+31.70 Δ = 44°19'22" (RT) D = 03'10'59" T = 733.15 L = 1,392.45 PC STA. = 654+98.54 PCC STA. = 668+90.99 e = 0.060 D.S. = 50 mph	<b>CURVE DATA 429_R_C1_5</b> PI STA. = 677+98.29 Δ = 01°43'51" (LT) D = 00'05'43" T = 907.31 L = 1,814.47 PC STA. = 668+90.99 PCC STA. = 687+05.46 e = N/C D.S. = 50 mph
---	---	---	---	---

<b>CURVE DATA 429_R_C2_1</b> PI STA. = 830+70.05 Δ = 28°51'22" (LT) D = 04'47'10" T = 308.00 L = 602.92 PC STA. = 827+62.05 PCC STA. = 833+64.97 e = 0.081 D.S. = 50 mph	<b>CURVE DATA 429_R_C2_2</b> PI STA. = 844+22.52 Δ = 00°57'39" (RT) D = 04'31'46" T = 1,057.35 L = 1,761.67 PC STA. = 833+64.97 PCC STA. = 851+26.64 e = 0.078 D.S. = 50 mph	<b>CURVE DATA 429_R_C2_3</b> PI STA. = 861+39.64 Δ = 00°57'39" (RT) D = 00'03'26" T = 036.05 L = 1,672.06 PC STA. = 853+03.59 PCC STA. = 869+75.65 e = N/C D.S. = 50 mph	<b>CURVE DATA 429_R_C2_4</b> PI STA. = 884+30.92 Δ = 01°53'30" (RT) D = 00'14'57" T = 376.37 L = 752.67 PC STA. = 880+54.55 PCC STA. = 888+07.22 e = N/C D.S. = 50 mph	<b>CURVE DATA 429_R_C3_1</b> PI STA. = 703+32.12 Δ = 32°31'38" (RT) D = 03'08'28" T = 532.12 L = 1,035.50 PC STA. = 700+00.00 PCC STA. = 710+35.50 e = 0.060 D.S. = 50 mph	<b>CURVE DATA 429_R_C3_2</b> PI STA. = 726+80.91 Δ = 49°32'58" (RT) D = 04'46'29" T = 553.84 L = 1,037.76 PC STA. = 720+55.07 PCC STA. = 730+92.83 e = 0.081 D.S. = 50 mph
---	---	---	---	---	---

<b>CURVE DATA 429_R_D1_1</b> PI STA. = 136+56.42 Δ = 20°19'35" (LT) D = 01'49'45" T = 561.55 L = 1,111.30 PC STA. = 130+94.87 PCC STA. = 142+06.17 e = 0.037 D.S. = 50 mph	<b>CURVE DATA 429_R_D1_2</b> PI STA. = 218+57.50 Δ = 04°11'44" (RT) D = 00'22'55" T = 549.45 L = 1,226.25 PC STA. = 213+08.04 PCC STA. = 224+06.46 e = N/C D.S. = 50 mph	<b>CURVE DATA 429_R_D1_3</b> PI STA. = 239+14.19 Δ = 50°11'06" (LT) D = 04'05'33" T = 655.58 L = 1,226.25 PC STA. = 232+50.61 PCC STA. = 249+69.24 e = 0.073 D.S. = 50 mph	<b>CURVE DATA 429_R_D1_4</b> PI STA. = 250+30.50 Δ = 02°27'33" (RT) D = 01'30'48" T = 81.26 L = 162.30 PC STA. = 249+69.24 PCC STA. = 251+31.74 D.S. = 50 mph	<b>CURVE DATA 429_R_D2_1</b> PI STA. = 255+45.85 Δ = 05°30'39" (RT) D = 00'41'03" T = 414.12 L = 827.36 PC STA. = 251+31.74 PCC STA. = 260+15.20 e = N/C D.S. = 50 mph	<b>CURVE DATA 429_R_D2_2</b> PI STA. = 269+57.90 Δ = 64°17'45" (LT) D = 03'49'11" T = 445.10 L = 889.92 PC STA. = 260+15.20 PCC STA. = 276+98.46 e = 0.070 D.S. = 50 mph	<b>CURVE DATA 429_R_D2_3</b> PI STA. = 281+43.56 Δ = 03°27'55" (RT) D = 00'23'22" T = 445.10 L = 889.92 PC STA. = 276+98.46 PCC STA. = 285+88.38 e = N/C D.S. = 50 mph
---	---	---	---	---	---	---

<b>CURVE DATA 429_R_D3_1</b> PI STA. = 304+86.57 Δ = 00'04'35" T = 446.53 L = 893.06 PC STA. = 300+00.00 PCC STA. = 300+93.06 e = N/C D.S. = 50 mph	<b>CURVE DATA 429_R_D3_2</b> PI STA. = 311+47.09 Δ = 06°08'49" T = 254.03 L = 496.01 PC STA. = 308+93.06 PCC STA. = 324+61.71 e = N/C D.S. = 50 mph	<b>CURVE DATA 429_R_D3_3</b> PI STA. = 320+29'21" (RT) Δ = 70°44'42" (RT) D = 06°35'44" T = 312.83 L = 1,034.98 PC STA. = 324+61.71 PCC STA. = 334+96.69 e = N/C D.S. = 70 mph	<b>CURVE DATA 429_R_D3_4</b> PI STA. = 329+79.24 Δ = 01°50'39" (RT) D = 00'10'39" T = 312.83 L = 1,034.98 PC STA. = 324+61.71 PCC STA. = 334+96.69 e = N/C D.S. = 70 mph
---	---	---	---



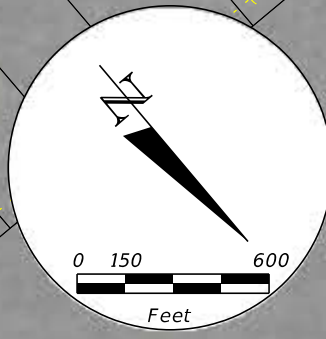
\$TIMES \$USERS  
 c:\pwworkspace\user\0419471\PLMRD\_2\_02main.dgn

REVISIONS		REVISIONS		ENGINEER OF RECORD		STATE OF FLORIDA DEPARTMENT OF TRANSPORTATION			SHEET NO. 4
DATE	DESCRIPTION	DATE	DESCRIPTION			ROAD NO.	COUNTY	FINANCIAL PROJECT ID	
				RAMON F. BRETON LICENSE NUMBER: 53139 KIMLEY HORN AND ASSOCIATES, INC. 189 S ORANGE AVE. SUITE 1000, ORLANDO, FL 32801		OSCEOLA & POLK	OSCEOLA	446581-1-22-01	

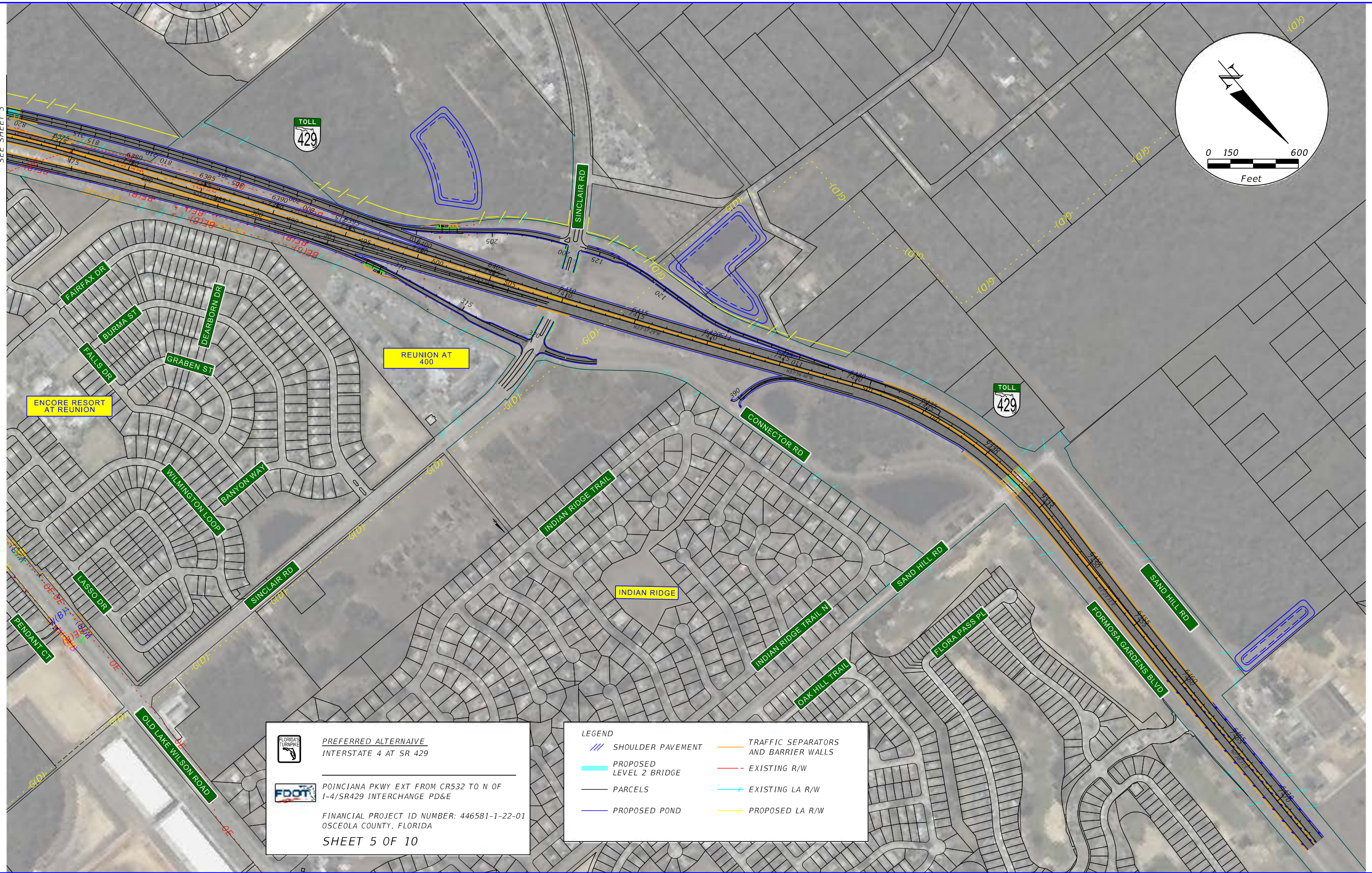
# ALIGNMENT SHEET

FAC NOTE





SEE SHEET 3



**FLORIDA TURNPIKE**  
**FDOT**  
 PREFERRED ALTERNATIVE  
 INTERSTATE 4 AT SR 429  
 POINCIANA PKWY EXT FROM CR532 TO N OF I-4/SR429 INTERCHANGE PD&E  
 FINANCIAL PROJECT ID NUMBER: 446581-1-22-01  
 OSCEOLA COUNTY, FLORIDA  
 SHEET 5 OF 10

**LEGEND**

SHOULDER PAVEMENT	TRAFFIC SEPARATORS AND BARRIER WALLS
PROPOSED LEVEL 2 BRIDGE	EXISTING R/W
PARCELS	EXISTING LA R/W
PROPOSED POND	PROPOSED LA R/W

\$TIMES \$USERS  
 c:\pw\work\vrsh\_pw\user\0419471\PLANRD\_2\_01New.dgn

REVISIONS	
DATE	DESCRIPTION

**ENGINEER OF RECORD**  
 RAMON F. BRETON  
 LICENSE NUMBER: 53139  
 KIMLEY HORN AND ASSOCIATES, INC.  
 189 S ORANGE AVE. SUITE 1000,  
 ORLANDO, FL 32801

STATE OF FLORIDA DEPARTMENT OF TRANSPORTATION		
ROAD NO.	COUNTY	FINANCIAL PROJECT ID
	OSCEOLA & POLK	446581-1-22-01

PLAN SHEET

SHEET NO.  
5

FAC NOTE





PREFERRED ALTERNATIVE  
INTERSTATE 4 AT SR 429

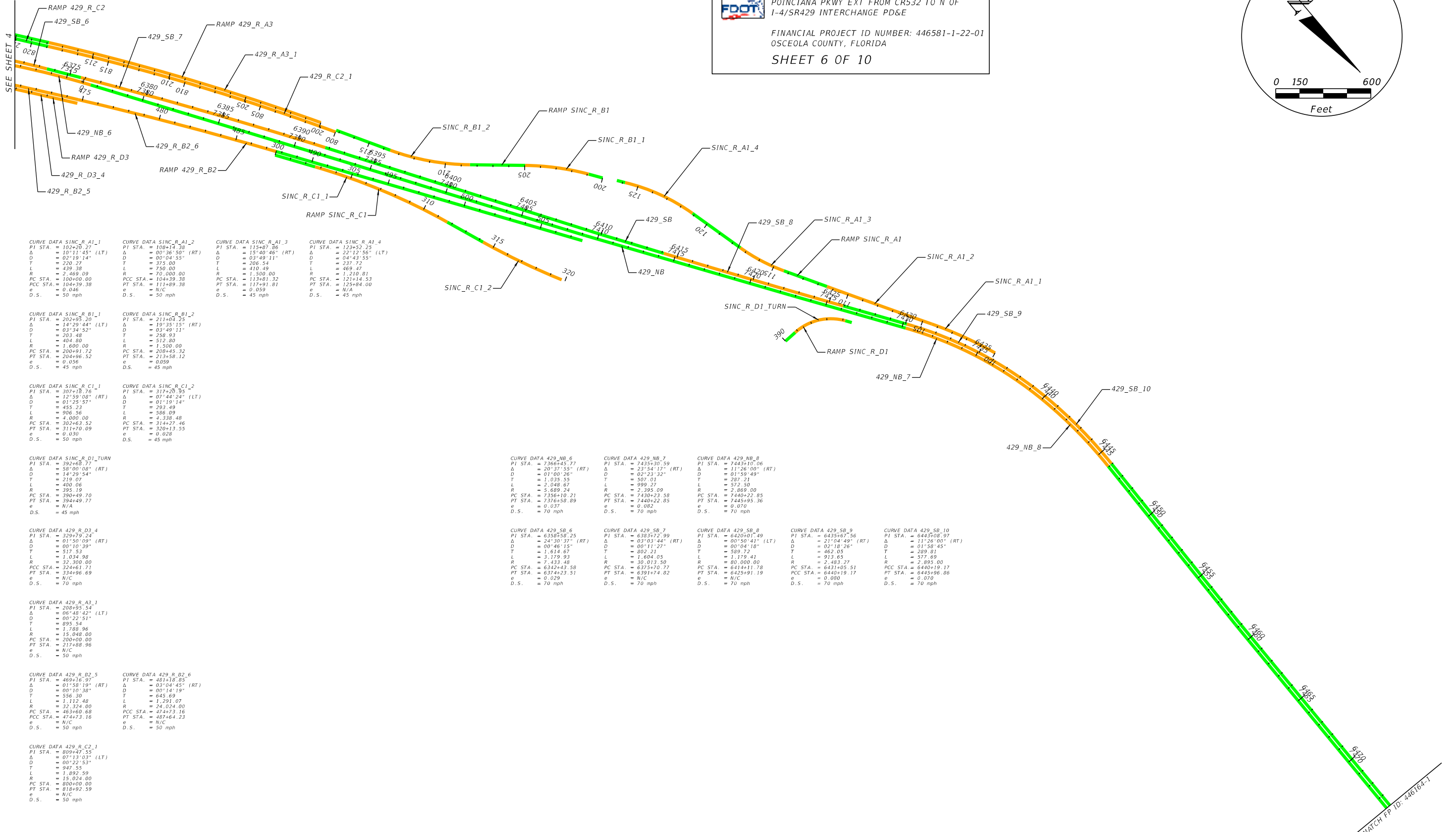
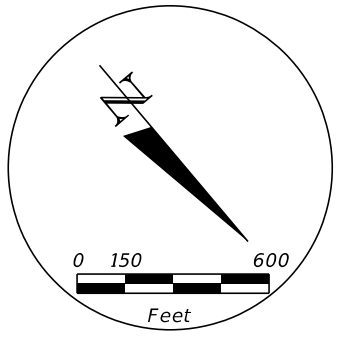


POINCIANA PKWY EXT FROM CR532 TO N OF  
I-4/SR429 INTERCHANGE PD&E

FINANCIAL PROJECT ID NUMBER: 446581-1-22-01  
OSCEOLA COUNTY, FLORIDA

SHEET 6 OF 10

**LEGEND**  
 DENOTES TANGENT SECTIONS  
 DENOTES CURVE SECTIONS



**CURVE DATA SINC\_R\_A1\_1**  
 PI STA. = 102+20.27  
 $\Delta$  = 101°11'45" (LT)  
 D = 02°19'14"  
 T = 220.27  
 L = 439.38  
 R = 2,469.09  
 PC STA. = 100+00.00  
 PCC STA. = 104+39.38  
 e = 0.046  
 D.S. = 50 mph

**CURVE DATA SINC\_R\_B1\_1**  
 PI STA. = 202+05.20  
 $\Delta$  = 14°29'44" (LT)  
 D = 03°34'52"  
 T = 203.48  
 L = 404.80  
 R = 1,600.00  
 PC STA. = 200+01.72  
 PT STA. = 204+96.52  
 e = 0.036  
 D.S. = 45 mph

**CURVE DATA SINC\_R\_C1\_1**  
 PI STA. = 307+18.76  
 $\Delta$  = 12°59'08" (RT)  
 D = 01°25'53"  
 T = 455.23  
 L = 906.56  
 R = 4,000.00  
 PC STA. = 302+63.52  
 PT STA. = 311+70.09  
 e = 0.030  
 D.S. = 50 mph

**CURVE DATA SINC\_R\_D1\_TURN**  
 PI STA. = 392+68.77  
 $\Delta$  = 58°00'00" (RT)  
 D = 14°29'54"  
 T = 219.07  
 L = 400.06  
 R = 395.19  
 PC STA. = 390+49.70  
 PT STA. = 394+49.77  
 e = N/A  
 D.S. = 45 mph

**CURVE DATA 429\_R\_D3\_4**  
 PI STA. = 329+39.24  
 $\Delta$  = 01°50'09" (RT)  
 D = 00°10'39"  
 T = 517.53  
 L = 1,034.98  
 R = 32,300.00  
 PCC STA. = 324+61.71  
 PT STA. = 334+96.69  
 e = N/C  
 D.S. = 70 mph

**CURVE DATA 429\_R\_A3\_1**  
 PI STA. = 208+95.54  
 $\Delta$  = 06°48'42" (LT)  
 D = 00°22'51"  
 T = 895.54  
 L = 1,788.96  
 R = 15,048.00  
 PC STA. = 200+00.00  
 PT STA. = 217+88.96  
 e = N/C  
 D.S. = 50 mph

**CURVE DATA 429\_R\_B2\_5**  
 PI STA. = 469+16.97  
 $\Delta$  = 01°58'15" (RT)  
 D = 00°10'38"  
 T = 556.30  
 L = 1,112.48  
 R = 32,324.00  
 PC STA. = 463+60.68  
 PCC STA. = 474+73.16  
 e = N/C  
 D.S. = 50 mph

**CURVE DATA 429\_R\_C2\_1**  
 PI STA. = 809+47.55  
 $\Delta$  = 07°13'03" (LT)  
 D = 00°22'53"  
 T = 947.55  
 L = 1,892.59  
 R = 15,024.00  
 PC STA. = 800+00.00  
 PT STA. = 818+92.59  
 e = N/C  
 D.S. = 50 mph

**CURVE DATA SINC\_R\_B1\_2**  
 PI STA. = 211+04.25  
 $\Delta$  = 19°35'15" (RT)  
 D = 03°49'11"  
 T = 258.93  
 L = 512.80  
 R = 1,500.00  
 PC STA. = 209+45.32  
 PT STA. = 213+58.12  
 e = 0.059  
 D.S. = 45 mph

**CURVE DATA SINC\_R\_C1\_2**  
 PI STA. = 317+20.35  
 $\Delta$  = 07°44'24" (LT)  
 D = 01°19'14"  
 T = 293.49  
 L = 586.09  
 R = 4,338.48  
 PC STA. = 314+27.46  
 PT STA. = 320+13.55  
 e = 0.029  
 D.S. = 45 mph

**CURVE DATA 429\_NB\_6**  
 PI STA. = 7366+45.77  
 $\Delta$  = 20°37'55" (RT)  
 D = 01°00'26"  
 T = 1,035.35  
 L = 2,048.67  
 R = 5,689.24  
 PC STA. = 7356+10.21  
 PT STA. = 7376+58.89  
 e = 0.037  
 D.S. = 70 mph

**CURVE DATA 429\_NB\_7**  
 PI STA. = 7435+30.59  
 $\Delta$  = 23°54'17" (RT)  
 D = 02°23'32"  
 T = 507.01  
 L = 999.27  
 R = 2,395.09  
 PC STA. = 7430+23.38  
 PT STA. = 7440+22.85  
 e = 0.082  
 D.S. = 70 mph

**CURVE DATA 429\_NB\_8**  
 PI STA. = 7443+10.06  
 $\Delta$  = 11°26'00" (RT)  
 D = 01°59'49"  
 T = 287.21  
 L = 572.50  
 R = 2,869.00  
 PC STA. = 7440+22.85  
 PT STA. = 7446+95.36  
 e = 0.070  
 D.S. = 70 mph

**CURVE DATA 429\_SB\_6**  
 PI STA. = 6358+58.25  
 $\Delta$  = 24°30'37" (RT)  
 D = 00°46'15"  
 T = 1,614.67  
 L = 3,179.93  
 R = 7,433.48  
 PC STA. = 6340+43.58  
 PT STA. = 6374+23.51  
 e = 0.029  
 D.S. = 70 mph

**CURVE DATA 429\_SB\_7**  
 PI STA. = 6383+72.99  
 $\Delta$  = 03°03'44" (RT)  
 D = 00°11'27"  
 T = 1,604.05  
 L = 3,013.50  
 R = 30,013.50  
 PC STA. = 6374+70.77  
 PT STA. = 6391+74.82  
 e = N/C  
 D.S. = 70 mph

**CURVE DATA 429\_SB\_8**  
 PI STA. = 6420+01.49  
 $\Delta$  = 00°50'41" (LT)  
 D = 00°04'18"  
 T = 589.72  
 L = 1,179.41  
 R = 80,000.00  
 PC STA. = 6414+11.78  
 PT STA. = 6425+91.19  
 e = N/C  
 D.S. = 70 mph

**CURVE DATA 429\_SB\_9**  
 PI STA. = 6435+67.56  
 $\Delta$  = 21°04'49" (RT)  
 D = 02°18'26"  
 T = 462.05  
 L = 913.65  
 R = 2,483.27  
 PC STA. = 6431+05.51  
 PT STA. = 6440+19.17  
 e = 0.080  
 D.S. = 70 mph

**CURVE DATA 429\_SB\_10**  
 PI STA. = 6443+08.97  
 $\Delta$  = 11°26'00" (RT)  
 D = 01°58'45"  
 T = 209.81  
 L = 577.69  
 R = 2,895.00  
 PC STA. = 6440+19.17  
 PT STA. = 6445+96.86  
 e = 0.070  
 D.S. = 70 mph

\$TIMES \$USERS  
 c:\pwworkspace\user\pwworkspace\user\40419471\PLANNING\_2\_02New.dgn

REVISIONS		REVISIONS		ENGINEER OF RECORD		STATE OF FLORIDA DEPARTMENT OF TRANSPORTATION			ALIGNMENT SHEET	SHEET NO.	
DATE	DESCRIPTION	DATE	DESCRIPTION	RAMON F. BRETON LICENSE NUMBER: 53139 KIMLEY HORN AND ASSOCIATES, INC. 189 S ORANGE AVE. SUITE 1000, ORLANDO, FL 32801		ROAD NO.	COUNTY	FINANCIAL PROJECT ID		6	6
						OSCEOLA & POLK	446581-1-22-01				

FAC NOTE



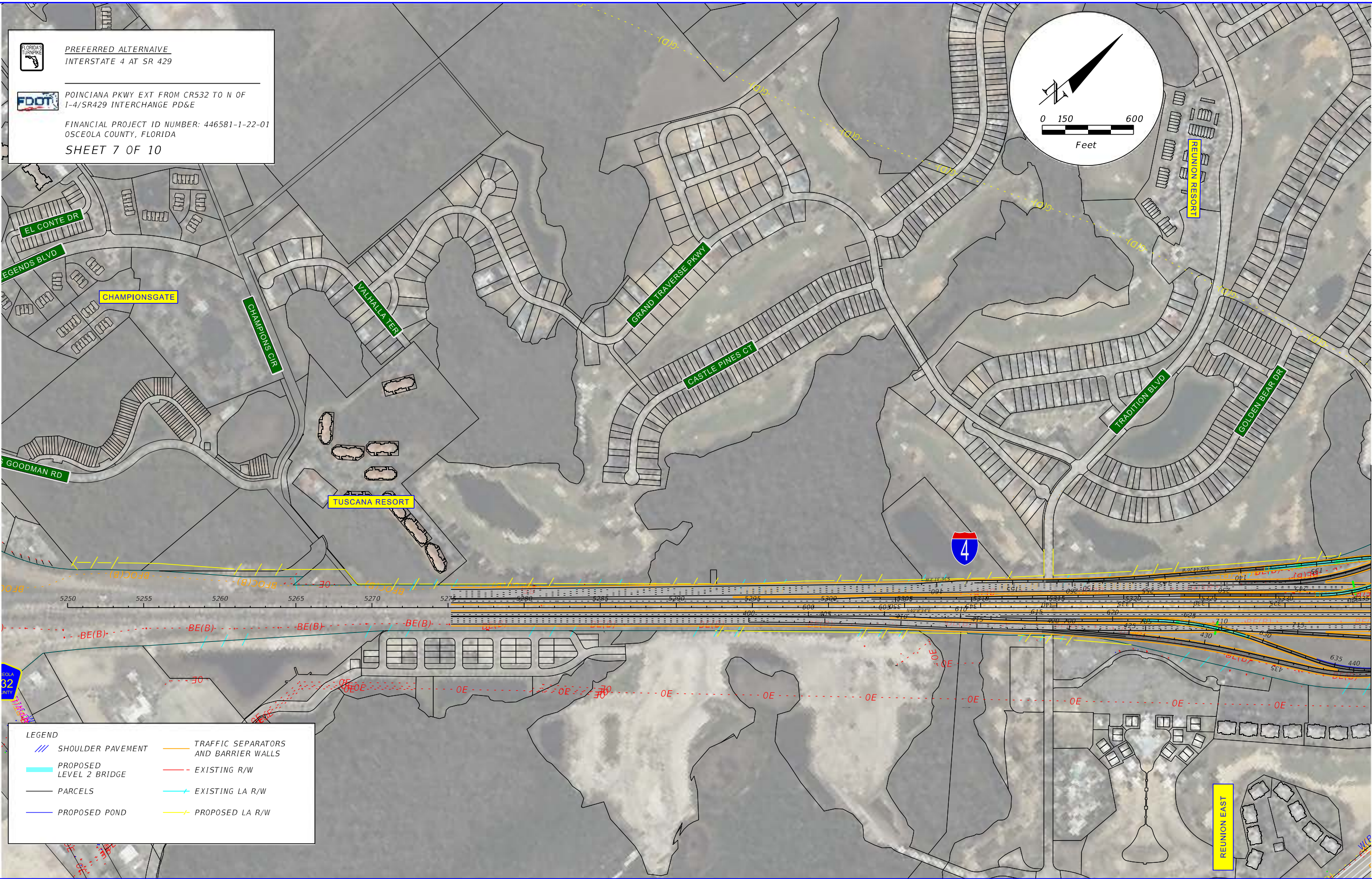
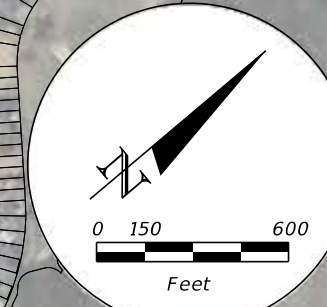


PREFERRED ALTERNATIVE  
INTERSTATE 4 AT SR 429



POINCIANA PKWY EXT FROM CR532 TO N OF  
I-4/SR429 INTERCHANGE PD&E

FINANCIAL PROJECT ID NUMBER: 446581-1-22-01  
OSCEOLA COUNTY, FLORIDA  
SHEET 7 OF 10



LEGEND	
	SHOULDER PAVEMENT
	PROPOSED LEVEL 2 BRIDGE
	PARCELS
	PROPOSED POND
	TRAFFIC SEPARATORS AND BARRIER WALLS
	EXISTING R/W
	EXISTING LA R/W
	PROPOSED LA R/W

\$TIMES \$USERS  
 c:\pw\work\vrsh\_pw\pw\_user\40419471\PLANRD\_2\_01New.dgn

SEE SHEET 3

REVISIONS		ENGINEER OF RECORD		STATE OF FLORIDA DEPARTMENT OF TRANSPORTATION		SHEET NO.
DATE	DESCRIPTION	DATE	DESCRIPTION	ROAD NO.	COUNTY	
					OSCEOLA & POLK	7
					FINANCIAL PROJECT ID	
					446581-1-22-01	

# PLAN SHEET

FAC NOTE





PREFERRED ALTERNATIVE  
INTERSTATE 4 AT SR 429



POINCIANA PKWY EXT FROM CR532 TO N OF  
I-4/SR429 INTERCHANGE PD&E

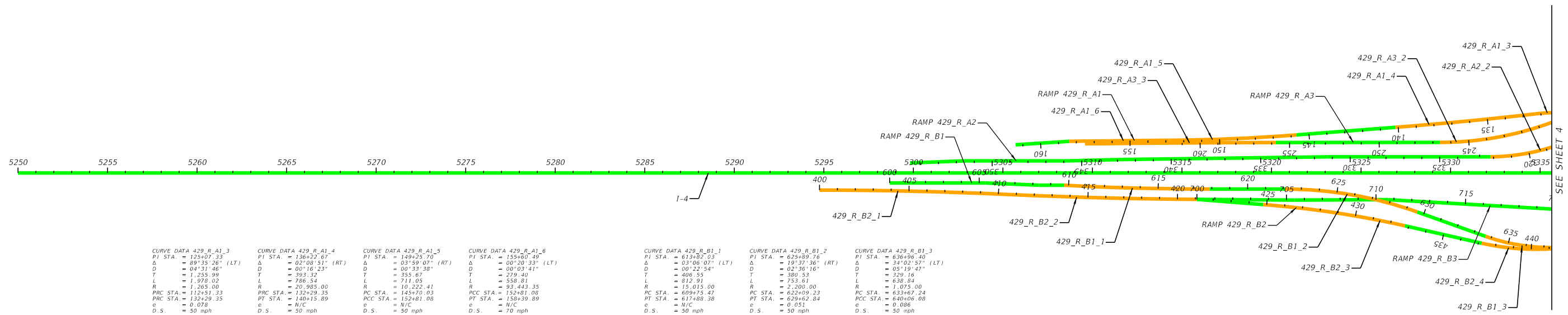
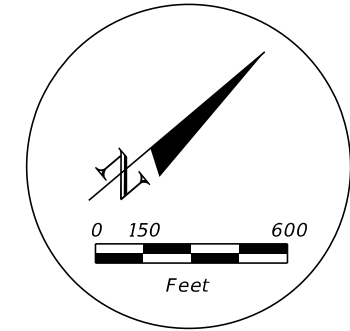
FINANCIAL PROJECT ID NUMBER: 446581-1-22-01  
OSCEOLA COUNTY, FLORIDA

SHEET 8 OF 10

LEGEND

— DENOTES TANGENT SECTIONS

— DENOTES CURVE SECTIONS



<p>CURVE DATA 429_R_A1_3 PI STA. = 125+07.33 Δ = 99°35'26" (LT) D = 04°31'46" T = 1,255.99 L = 1,978.02 R = 1,265.00 PRC STA. = 112+51.33 PT STA. = 132+29.35 e = 0.078 D.S. = 50 mph</p>	<p>CURVE DATA 429_R_A1_4 PI STA. = 136+22.67 Δ = 02°00'51" (RT) D = 00°16'23" T = 393.32 L = 786.54 R = 20,985.00 PRC STA. = 132+29.35 PT STA. = 140+15.99 e = N/C D.S. = 50 mph</p>	<p>CURVE DATA 429_R_A1_5 PI STA. = 149+25.70 Δ = 03°59'07" (RT) D = 00°33'38" T = 393.32 L = 786.54 R = 10,222.41 PRC STA. = 145+70.03 PT STA. = 152+81.08 e = N/C D.S. = 50 mph</p>	<p>CURVE DATA 429_R_A1_6 PI STA. = 155+60.49 Δ = 00°20'33" (LT) D = 00°03'41" T = 279.40 L = 558.81 R = 93,443.35 PRC STA. = 152+81.08 PT STA. = 158+39.89 e = N/C D.S. = 70 mph</p>	<p>CURVE DATA 429_R_B1_1 PI STA. = 613+82.03 Δ = 03°06'07" (LT) D = 00°22'54" T = 406.55 L = 812.91 R = 15,015.00 PRC STA. = 609+75.47 PT STA. = 617+88.98 e = N/C D.S. = 50 mph</p>	<p>CURVE DATA 429_R_B1_2 PI STA. = 625+89.76 Δ = 19°37'36" (RT) D = 02°36'16" T = 380.53 L = 753.61 R = 2,200.00 PRC STA. = 622+09.23 PT STA. = 629+62.04 e = 0.051 D.S. = 50 mph</p>	<p>CURVE DATA 429_R_B1_3 PI STA. = 636+96.40 Δ = 34°02'57" (LT) D = 05°19'47" T = 329.16 L = 638.84 R = 1,075.00 PRC STA. = 633+67.24 PT STA. = 640+06.08 e = 0.086 D.S. = 50 mph</p>	<p>CURVE DATA 429_R_B2_1 PI STA. = 405+24.64 Δ = 02°35'06" (RT) D = 00°14'47" T = 524.64 L = 1,049.19 R = 23,252.07 PRC STA. = 400+00.00 PT STA. = 410+49.10 e = N/C D.S. = 50 mph</p>	<p>CURVE DATA 429_R_B2_2 PI STA. = 415+98.03 Δ = 02°10'16" (LT) D = 00°12'18" T = 529.73 L = 1,059.34 R = 27,955.28 PRC STA. = 410+49.10 PT STA. = 421+08.43 e = N/C D.S. = 50 mph</p>	<p>CURVE DATA 429_R_B2_3 PI STA. = 428+81.44 Δ = 08°17'54" (RT) D = 01°02'14" T = 400.73 L = 800.07 R = 5,524.00 PRC STA. = 424+80.70 PT STA. = 432+80.77 e = 0.022 D.S. = 50 mph</p>	<p>CURVE DATA 429_R_B2_4 PI STA. = 451+44.53 Δ = 91°31'51" (LT) D = 04°08'02" T = 1,423.53 L = 2,214.15 R = 1,386.00 PRC STA. = 437+21.00 PT STA. = 459+35.15 e = 0.074 D.S. = 50 mph</p>
<p>CURVE DATA 429_R_A2_2 PI STA. = 217+42.77 Δ = 51°09'06" (RT) D = 04°59'59" T = 548.48 L = 1,023.11 R = 1,146.00 PRC STA. = 211+94.29 PT STA. = 222+17.40 e = 0.083 D.S. = 50 mph</p>	<p>CURVE DATA 429_R_A3_2 PI STA. = 236+56.85 Δ = 76°23'14" (RT) D = 03°10'59" T = 1,416.14 L = 2,399.78 R = 1,600.00 PRC STA. = 222+40.71 PT STA. = 246+40.49 e = 0.060 D.S. = 50 mph</p>	<p>CURVE DATA 429_R_A3_3 PI STA. = 258+74.67 Δ = 00°21'53" (LT) D = 00°03'41" T = 297.45 L = 594.90 R = 93,428.35 PRC STA. = 255+77.22 PT STA. = 261+72.12 e = N/C D.S. = 50 mph</p>								

\$DATE\$ \$USERS\$  
 c:\pw\work\vrsh\_pw\user\0419471\PLANRD\_2\_02New.dgn

<table border="1"> <thead> <tr> <th>DATE</th> <th>DESCRIPTION</th> <th>DATE</th> <th>DESCRIPTION</th> </tr> </thead> <tbody> <tr> <td> </td> <td> </td> <td> </td> <td> </td> </tr> </tbody> </table>				DATE	DESCRIPTION	DATE	DESCRIPTION					<p>ENGINEER OF RECORD</p> <p>RAMON F. BRETON LICENSE NUMBER: 53139 KIMLEY HORN AND ASSOCIATES, INC. 189 S ORANGE AVE. SUITE 1000, ORLANDO, FL 32801</p>		<p>STATE OF FLORIDA DEPARTMENT OF TRANSPORTATION</p> <table border="1"> <tr> <th>ROAD NO.</th> <th>COUNTY</th> <th>FINANCIAL PROJECT ID</th> </tr> <tr> <td> </td> <td>OSCEOLA &amp; POLK</td> <td>446581-1-22-01</td> </tr> </table>		ROAD NO.	COUNTY	FINANCIAL PROJECT ID		OSCEOLA & POLK	446581-1-22-01	<p>SHEET NO.</p> <p>8</p>	
DATE	DESCRIPTION	DATE	DESCRIPTION																				
ROAD NO.	COUNTY	FINANCIAL PROJECT ID																					
	OSCEOLA & POLK	446581-1-22-01																					

ALIGNMENT SHEET

FAC NOTE

**PREFERRED ALTERNATIVE**  
 INTERSTATE 4 AT SR 429

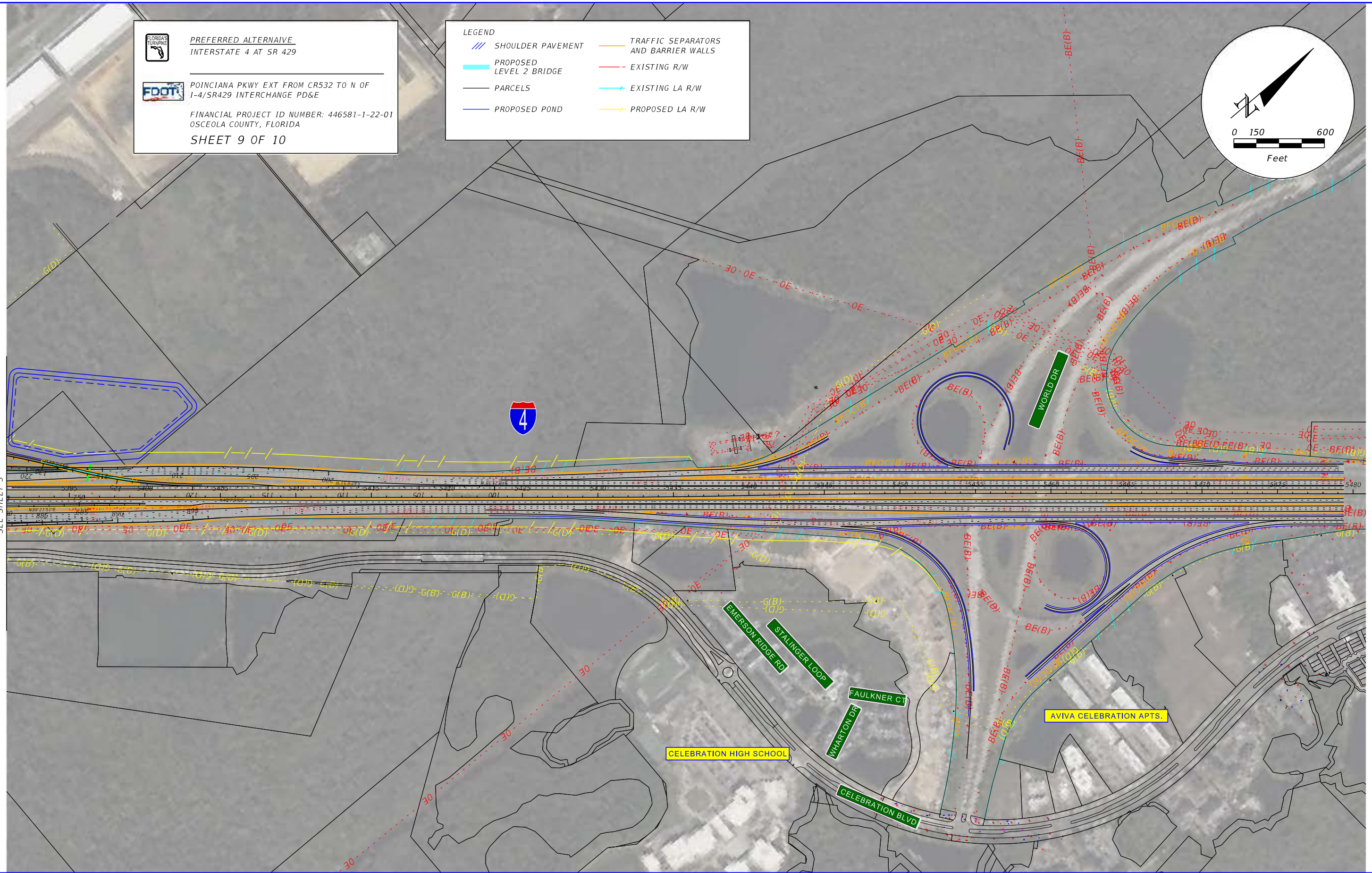
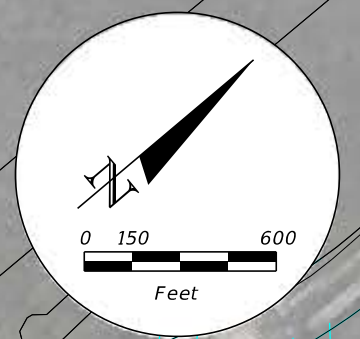
**FDOT**  
 POINCIANA PKWY EXT FROM CR532 TO N OF I-4/SR429 INTERCHANGE PD&E

FINANCIAL PROJECT ID NUMBER: 446581-1-22-01  
 OSCEOLA COUNTY, FLORIDA

**SHEET 9 OF 10**

**LEGEND**

	SHOULDER PAVEMENT		TRAFFIC SEPARATORS AND BARRIER WALLS
	PROPOSED LEVEL 2 BRIDGE		EXISTING R/W
	PARCELS		EXISTING LA R/W
	PROPOSED POND		PROPOSED LA R/W




SEE SHEET 3

\$DATE\$ \$TIME\$ \$USER\$  
 c:\pw\work\vrsh\_pw\pw\_user\0419471\PLANRD\_2\_01New.dgn


REVISIONS		REVISIONS		ENGINEER OF RECORD		STATE OF FLORIDA DEPARTMENT OF TRANSPORTATION		SHEET NO.
DATE	DESCRIPTION	DATE	DESCRIPTION			ROAD NO.	COUNTY	
				RAMON F. BRETON LICENSE NUMBER: 53139 KIMLEY HORN AND ASSOCIATES, INC. 189 S ORANGE AVE. SUITE 1000, ORLANDO, FL 32801			OSCEOLA & POLK	9
							446581-1-22-01	



**PLAN SHEET**

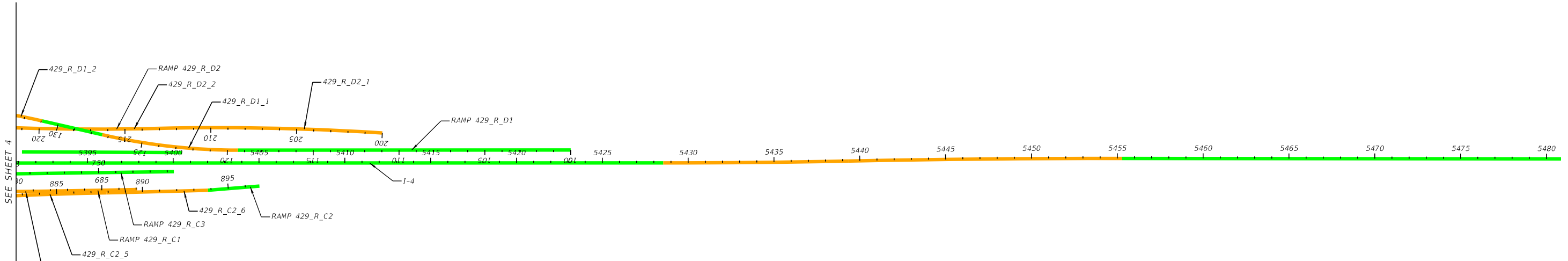
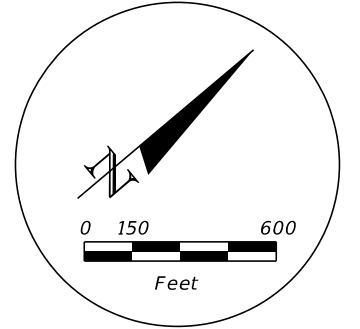
FAC NOTE


**PREFERRED ALTERNATIVE**  
 INTERSTATE 4 AT SR 429  


---


 POINCIANA PKWY EXT FROM CR532 TO N OF  
 I-4/SR429 INTERCHANGE PD&E  
 FINANCIAL PROJECT ID NUMBER: 446581-1-22-01  
 OSCEOLA COUNTY, FLORIDA  
**SHEET 10 OF 10**

**LEGEND**  
 DENOTES TANGENT SECTIONS  
 DENOTES CURVE SECTIONS



**CURVE DATA 429\_R\_C1\_5**  
 PI STA. = 677+98.20  
 Δ = 01°43'51" (LT)  
 D = 00°05'43"  
 T = 907.31  
 L = 1,814.47  
 R = 60.060.00  
 PRC STA. = 668+90.99  
 PT STA. = 682+05.46  
 e = N/C  
 D.S. = 50 mph

**CURVE DATA 429\_R\_C2\_5**  
 PI STA. = 884+30.92  
 Δ = 01°52'30" (RT)  
 D = 00°14'57"  
 T = 376.37  
 L = 752.67  
 R = 23.000.00  
 PRC STA. = 880+54.55  
 PRC STA. = 888+07.22  
 e = N/C  
 D.S. = 50 mph

**CURVE DATA 429\_R\_C2\_6**  
 PI STA. = 890+94.60  
 Δ = 00°32'54" (LT)  
 D = 00°05'43"  
 T = 287.46  
 L = 574.91  
 R = 60.075.00  
 PRC STA. = 888+07.22  
 PT STA. = 893+82.13  
 D.S. = 50 mph  
 TRANSITION SECTION

**CURVE DATA 429\_R\_D1\_1**  
 PI STA. = 123+39.13  
 Δ = 12°59'53" (RT)  
 D = 01°37'48"  
 T = 400.42  
 L = 797.40  
 R = 3,519.00  
 PC STA. = 119+38.71  
 PT STA. = 127+36.11  
 e = 0.034  
 D.S. = 50 mph

**CURVE DATA 429\_R\_D1\_2**  
 PI STA. = 136+56.42  
 Δ = 20°19'35" (LT)  
 D = 01°49'45"  
 T = 561.55  
 L = 1,111.30  
 R = 2,132.91  
 PC STA. = 130+94.87  
 PT STA. = 142+06.17  
 e = 0.037  
 D.S. = 50 mph

**CURVE DATA 429\_R\_D2\_1**  
 PI STA. = 206+54.44  
 Δ = 05°02'36" (LT)  
 D = 00°23'08"  
 T = 654.44  
 L = 1,308.04  
 R = 14,860.00  
 PT STA. = 200+00.00  
 PRC STA. = 213+08.04  
 e = N/C  
 D.S. = 50 mph

**CURVE DATA 429\_R\_D2\_2**  
 PI STA. = 218+57.50  
 Δ = 04°11'44" (RT)  
 D = 00°22'55"  
 T = 549.45  
 L = 1,098.42  
 R = 15,000.00  
 PRC STA. = 213+08.04  
 PT STA. = 224+09.46  
 e = N/C  
 D.S. = 50 mph

\$TIMES \$USERS  
 c:\pw\work\vrsh\_pw\pw\_user\0419471\PLANRD\_2\_02New.dgn

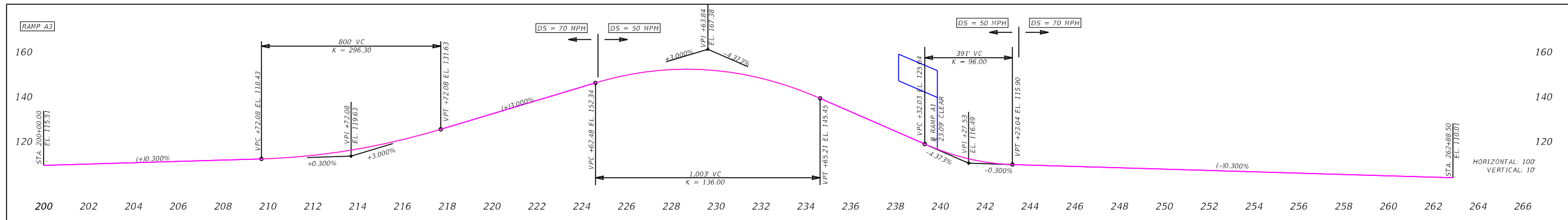
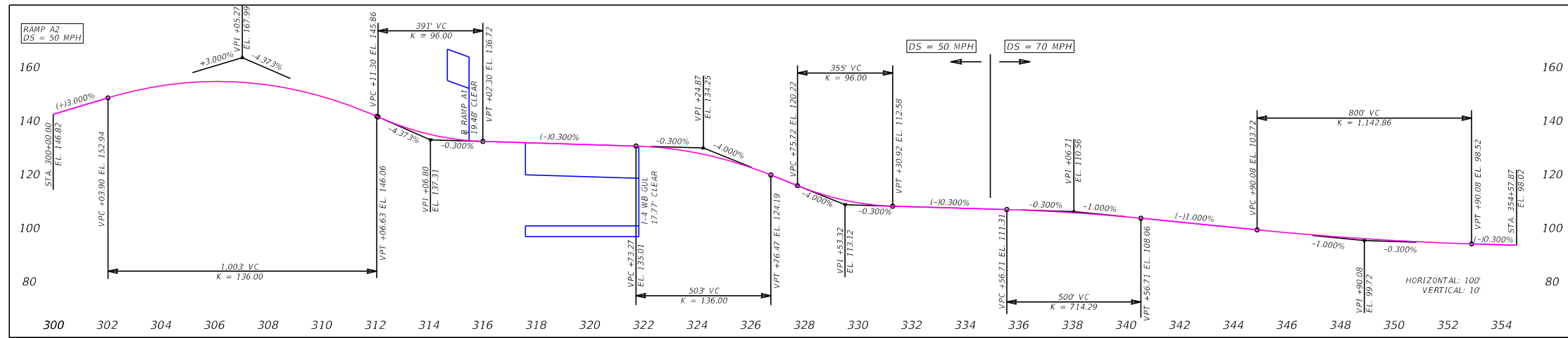
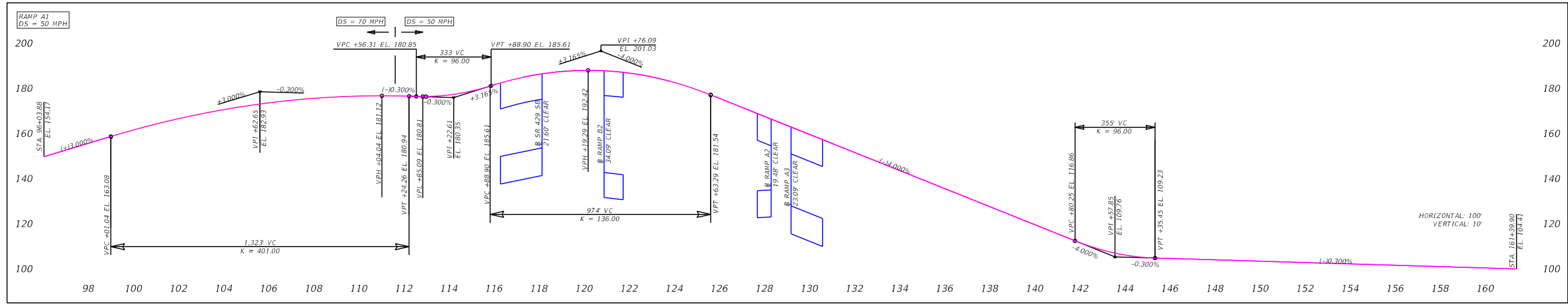
REVISIONS				ENGINEER OF RECORD		STATE OF FLORIDA DEPARTMENT OF TRANSPORTATION			<b>ALIGNMENT SHEET</b>	SHEET NO.
DATE	DESCRIPTION	DATE	DESCRIPTION	RAMON F. BRETON LICENSE NUMBER: 53139 KIMLEY HORN AND ASSOCIATES, INC. 189 S ORANGE AVE. SUITE 1000, ORLANDO, FL 32801		ROAD NO.	COUNTY	FINANCIAL PROJECT ID		10
						OSCEOLA & POLK	446581-1-22-01			

FAC NOTE



## APPENDIX D

### Vertical Profile Sheets for the Preferred Alternative



**PREFERRED ALTERNATIVE**  
 INTERSTATE 4 AT SR 429

**POINCIANA PKWY EXT FROM CR532 TO N OF 1-4/SR429 INTERCHANGE PD&E**

FINANCIAL PROJECT ID NUMBER: 446581-1-22-01  
 OSCEOLA COUNTY, FLORIDA

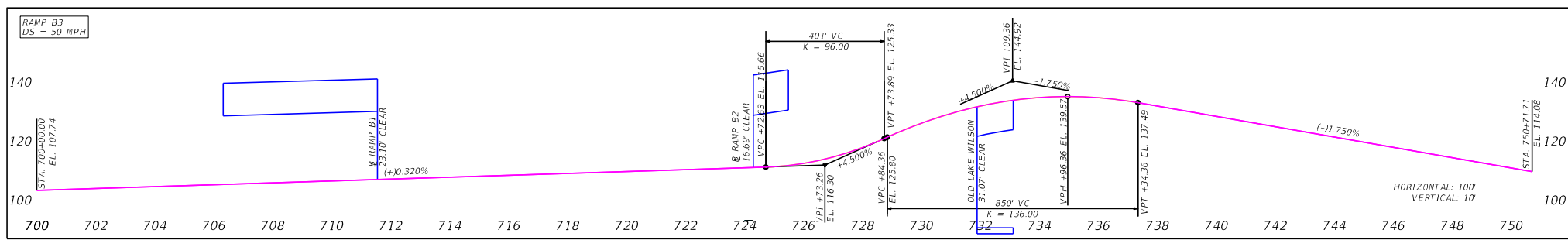
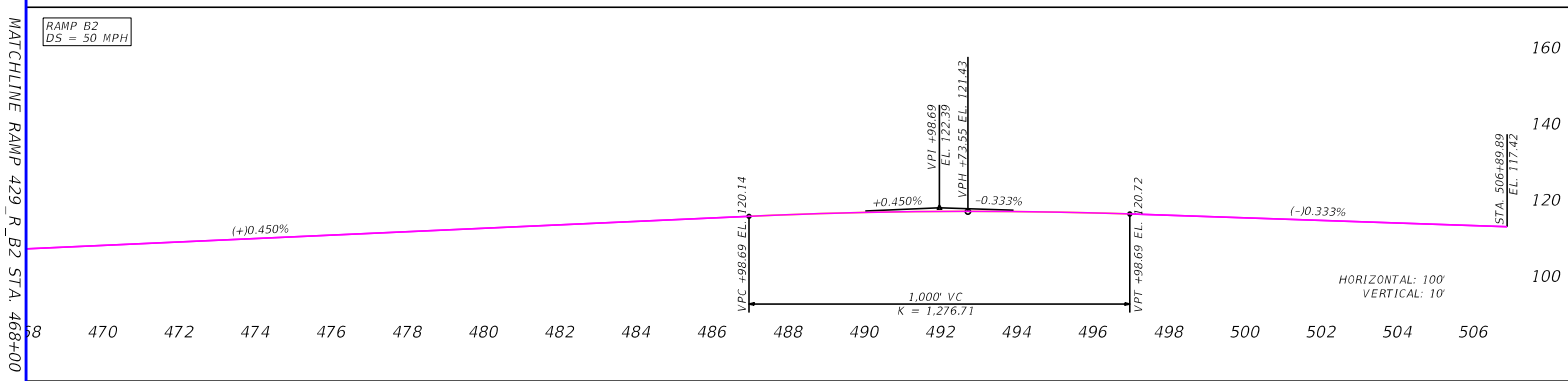
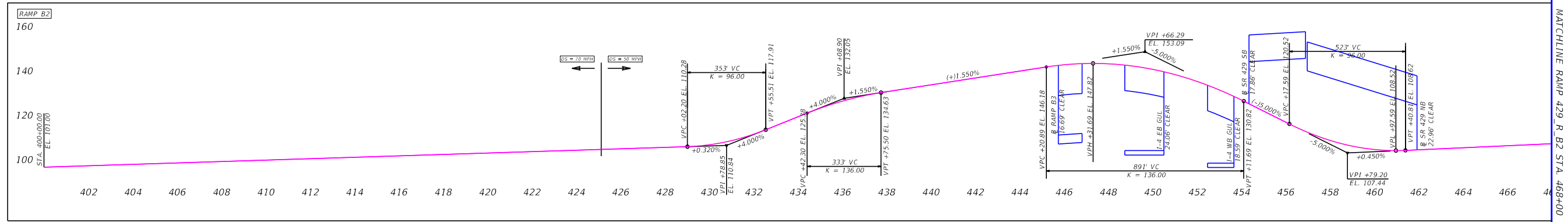
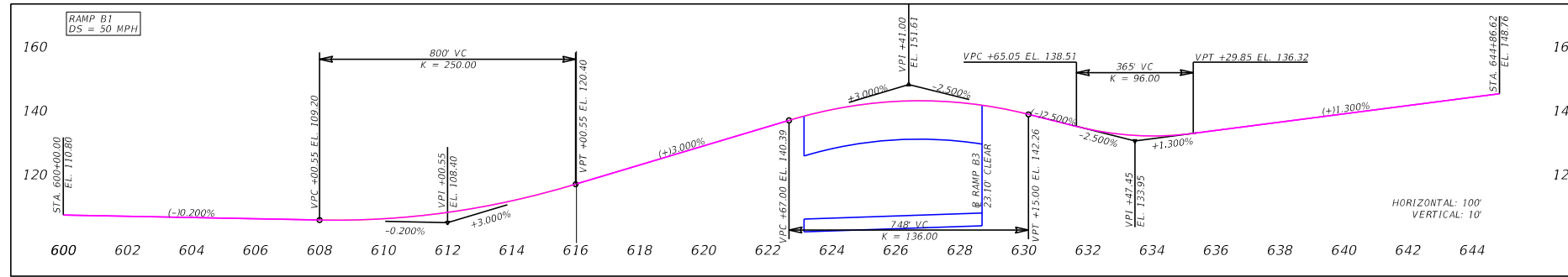
RAMP A

PROFILE SHEET (01)

1/24/2023 2:47:56 PM Chris.Davidson C:\pwworking\sh\_pwworking\user\0019471\PRORFD\_2\_01.dgn

REVISIONS		ENGINEER OF RECORD		STATE OF FLORIDA DEPARTMENT OF TRANSPORTATION			SHEET NO.
DATE	DESCRIPTION	DATE	DESCRIPTION	ROAD NO.	COUNTY	FINANCIAL PROJECT ID	
				SR 429	OSCEOLA & POLK	446581-1-22-01	

FAC NOTE



**PREFERRED ALTERNATIVE**  
**INTERSTATE 4 AT SR 429**

POINCIANA PKWY EXT FROM CR532 TO N OF  
 I-4/SR429 INTERCHANGE PD&E

FINANCIAL PROJECT ID NUMBER: 446581-1-22-01  
 OSCEOLA COUNTY, FLORIDA

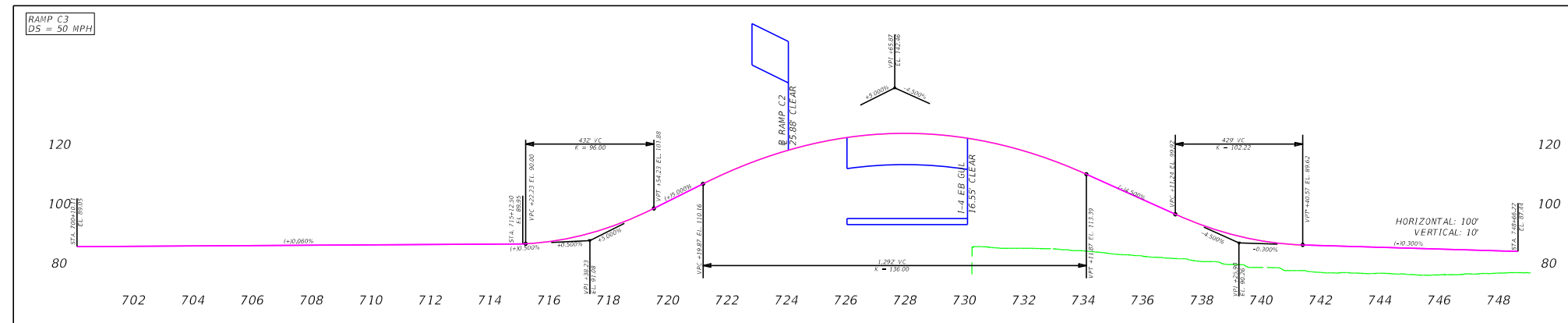
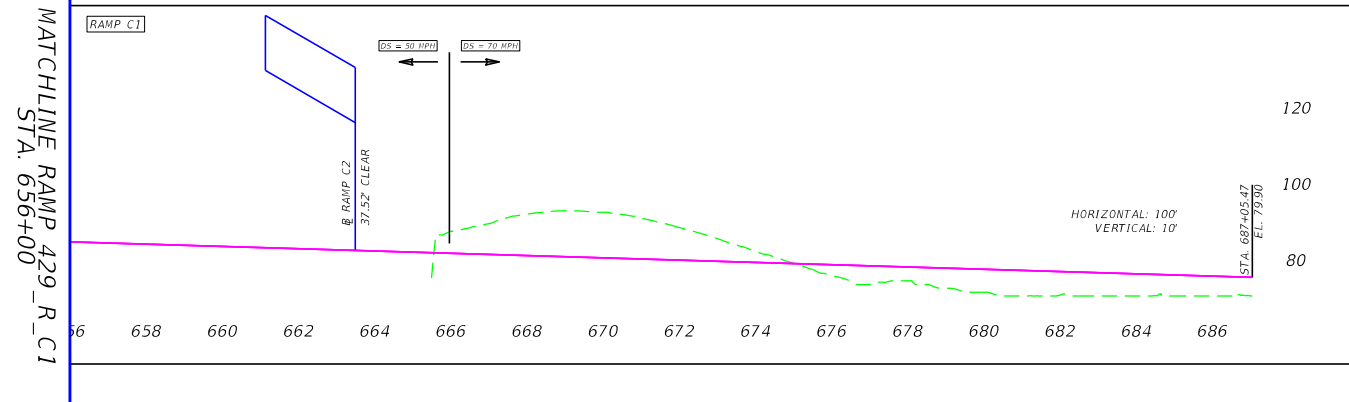
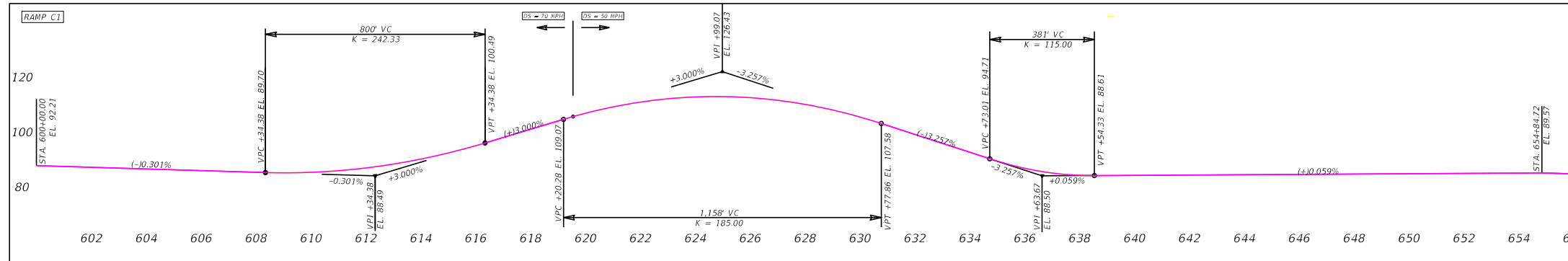
**RAMP B**

1/24/2023 3:42:01 PM Chris.Davidson C:\pwwork\1\sh\_pww\user\0019471\PRORFD\_2\_01.dgn

REVISIONS			ENGINEER OF RECORD			STATE OF FLORIDA DEPARTMENT OF TRANSPORTATION			SHEET NO.
DATE	DESCRIPTION	DATE	DESCRIPTION	ROAD NO.	COUNTY	FINANCIAL PROJECT ID	446581-1-22-01		
				SR 429	OSCEOLA & POLK				

**PROFILE SHEET (02)**

FAC NOTE



**PREFERRED ALTERNATIVE**  
INTERSTATE 4 AT SR 429

**FDOT** POINCIANA PKWY EXT FROM CR532 TO N OF I-4/SR429 INTERCHANGE PD&E

FINANCIAL PROJECT ID NUMBER: 446581-1-22-01  
OSCEOLA COUNTY, FLORIDA

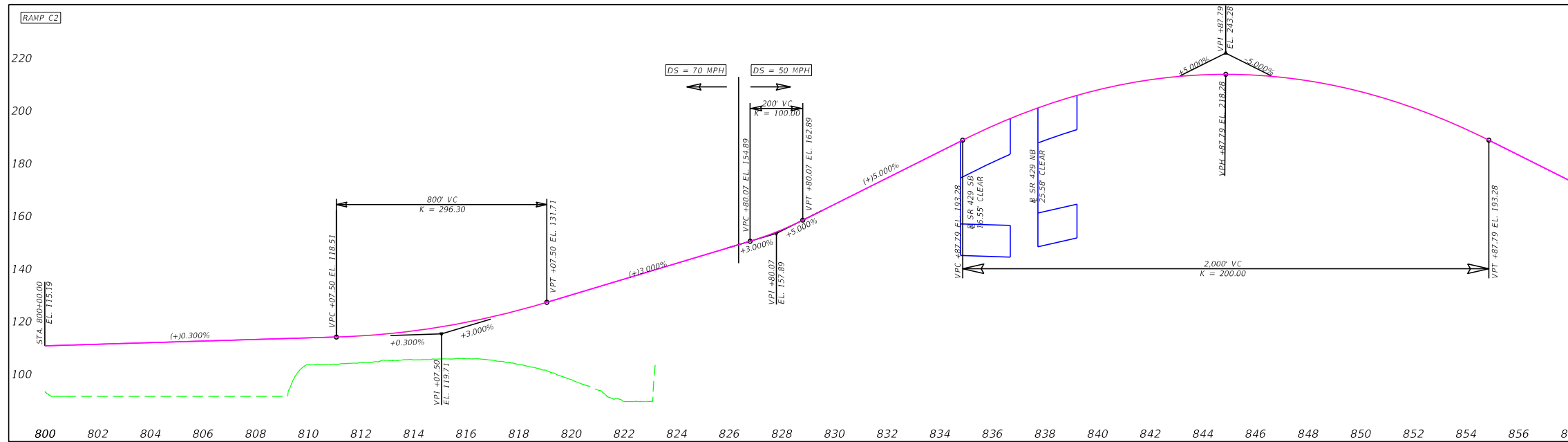
**RAMPS C1 & C3**

**PROFILE SHEET (03)**

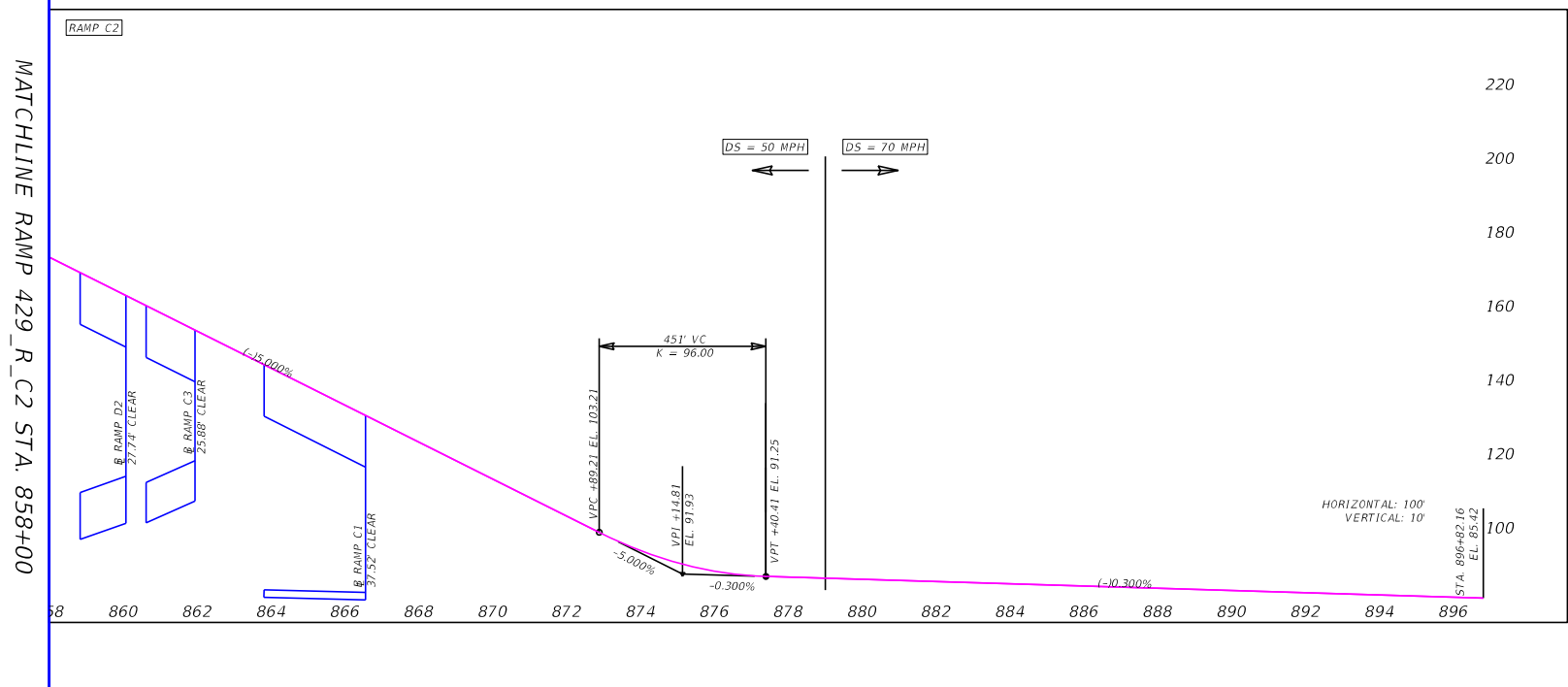
REVISIONS		ENGINEER OF RECORD		STATE OF FLORIDA DEPARTMENT OF TRANSPORTATION			SHEET NO.
DATE	DESCRIPTION	DATE	DESCRIPTION	ROAD NO.	COUNTY	FINANCIAL PROJECT ID	
				SR 429	OSCEOLA & POLK	446581-1-22-01	

1/24/2023 4:08:24 PM Chris.Davidson  
C:\pwworkspace\user\0019471\PROJECTS\2022\01\SR429\20220124\1-22-01-RAMP\_C1\_C3.dgn

FAC NOTE



MATCHLINE RAMP 429\_R\_C2 STA. 858+00



MATCHLINE RAMP 429\_R\_C2 STA. 858+00

**PREFERRED ALTERNATIVE**  
INTERSTATE 4 AT SR 429

---

**POINCIANA PKWY EXT FROM CR532 TO N OF I-4/SR429 INTERCHANGE PD&E**

FINANCIAL PROJECT ID NUMBER: 446581-1-22-01  
OSCEOLA COUNTY, FLORIDA

**RAMP C2**

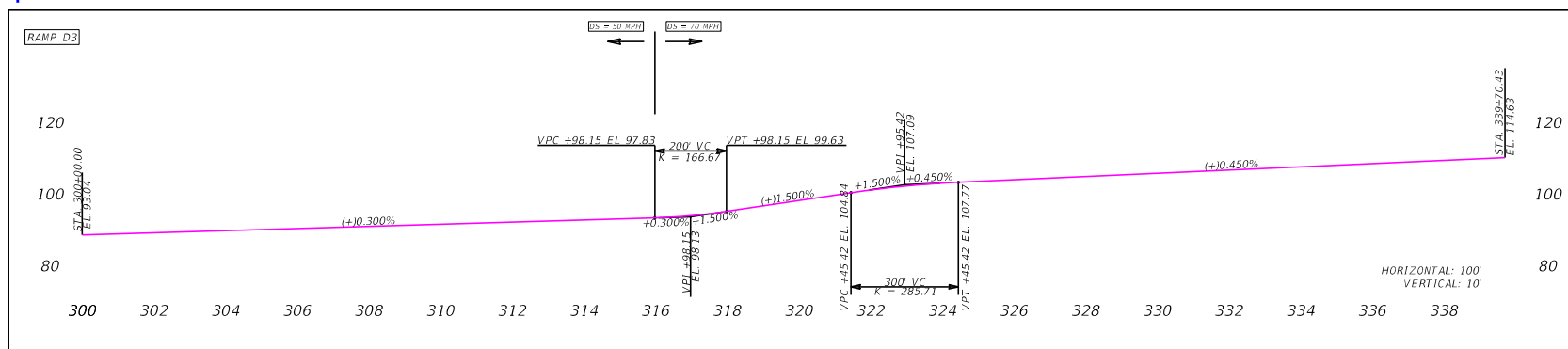
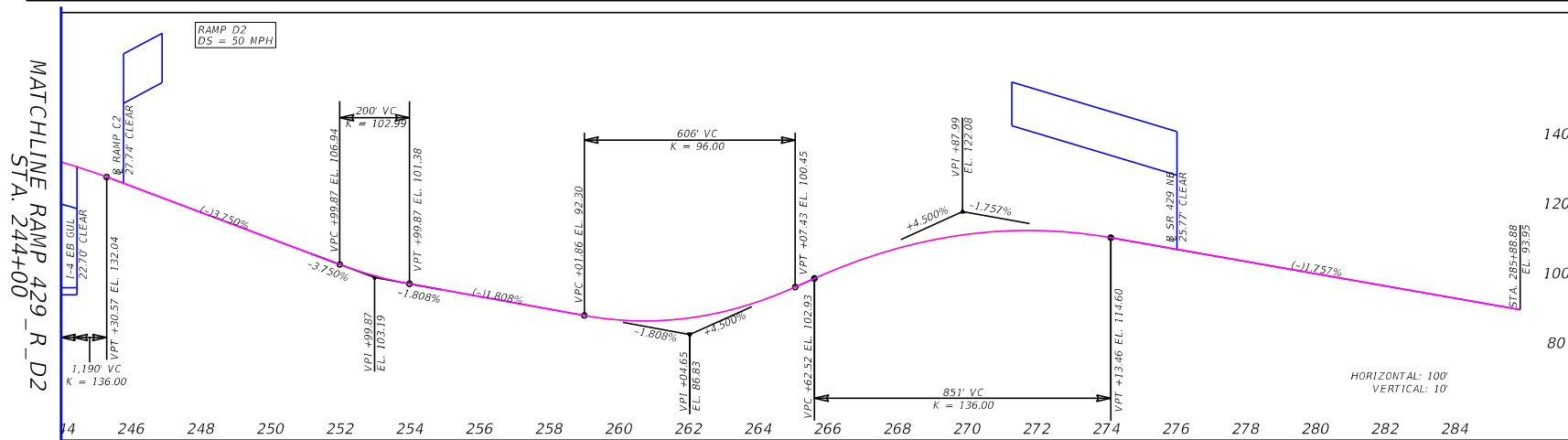
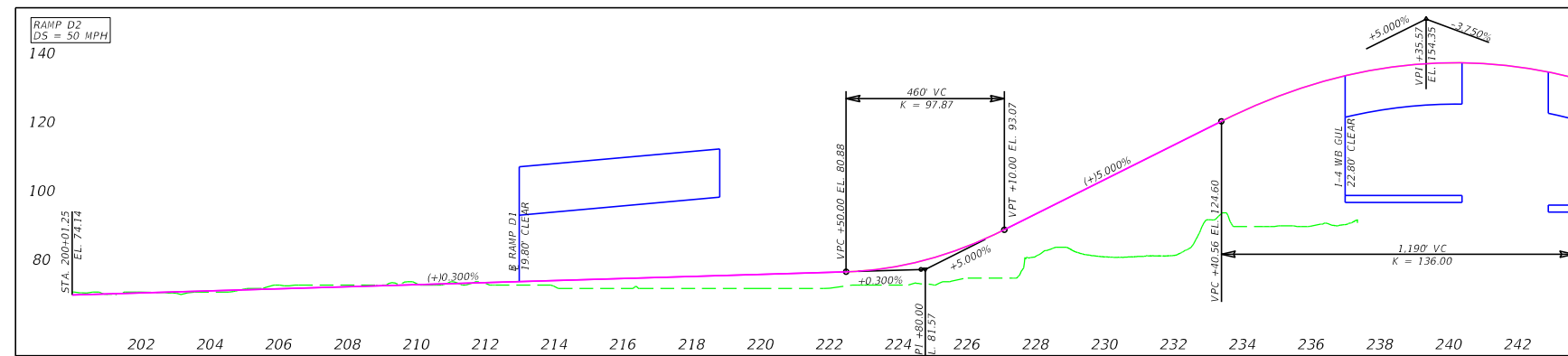
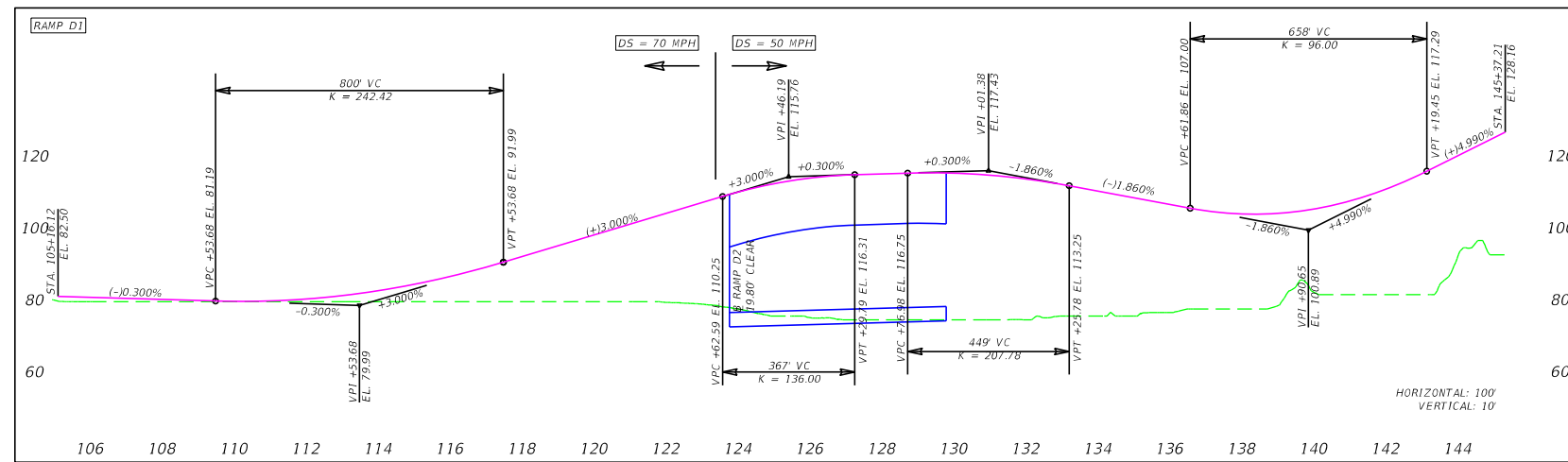
**PROFILE SHEET (04)**

1/19/2023 2:36:47 PM Chris.Davidson C:\pwworking\sh\_pwworking\user\0019471\PROJECTS\2022\01.dgn

REVISIONS		ENGINEER OF RECORD		STATE OF FLORIDA DEPARTMENT OF TRANSPORTATION			SHEET NO.
DATE	DESCRIPTION	DATE	DESCRIPTION	ROAD NO.	COUNTY	FINANCIAL PROJECT ID	
				SR 429	OSCEOLA & POLK	446581-1-22-01	

FAC NOTE





MATCHLINE RAMP 429\_R\_D2  
STA. 244+00

RAMP D

**PREFERRED ALTERNATIVE**  
INTERSTATE 4 AT SR 429

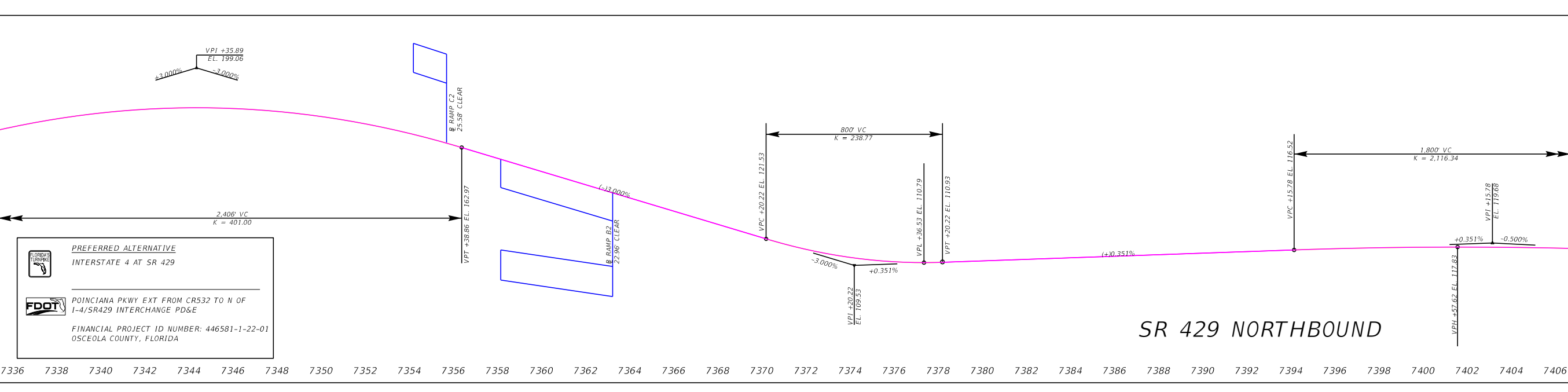
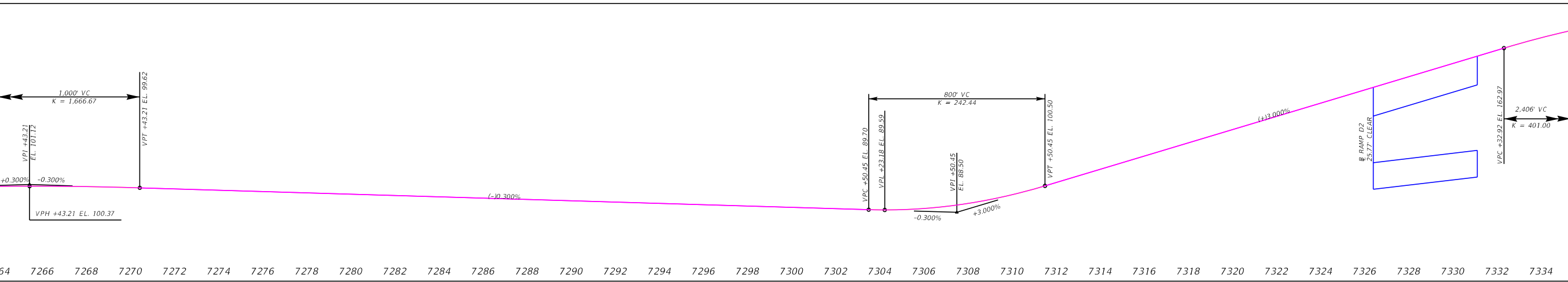
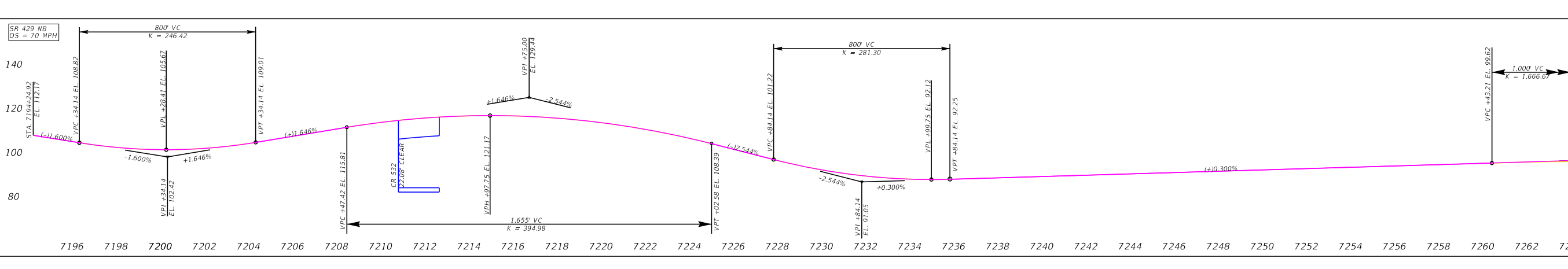
**POINCIANA PKWY EXT FROM CR532 TO N OF 1-4/SR429 INTERCHANGE PD&E**

FINANCIAL PROJECT ID NUMBER: 446581-1-22-01  
OSCEOLA COUNTY, FLORIDA

1/24/2023 4:22:43 PM Chris.Davidson C:\pwworking\user\19471\PRORFD\_2\_01.dgn

REVISIONS			ENGINEER OF RECORD			STATE OF FLORIDA DEPARTMENT OF TRANSPORTATION			SHEET NO.
DATE	DESCRIPTION	DATE	DESCRIPTION	ROAD NO.	COUNTY	FINANCIAL PROJECT ID	PROFILE SHEET (05)		
				SR 429	OSCEOLA & POLK	446581-1-22-01			

FAC NOTE



**PREFERRED ALTERNATIVE**  
INTERSTATE 4 AT SR 429

**FDOT** POINCIANA PKWY EXT FROM CRS32 TO N OF I-4/SR429 INTERCHANGE PDSE  
FINANCIAL PROJECT ID NUMBER: 446581-1-22-01  
OSCEOLA COUNTY, FLORIDA

SR 429 NORTHBOUND

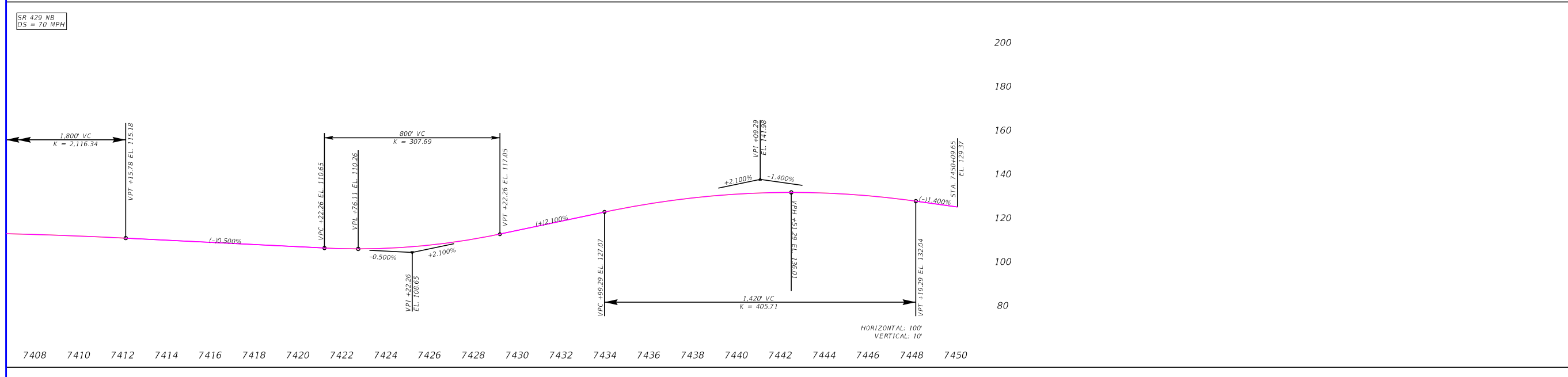
1/24/2023 4:33:52 PM Chris.Davidson C:\pwworking\user\0019471\PROJ\RD\_2\_01.dgn

REVISIONS		ENGINEER OF RECORD		STATE OF FLORIDA DEPARTMENT OF TRANSPORTATION			SHEET NO.
DATE	DESCRIPTION	DATE	DESCRIPTION	ROAD NO.	COUNTY	FINANCIAL PROJECT ID	
				SR 429	OSCEOLA & POLK	446581-1-22-01	

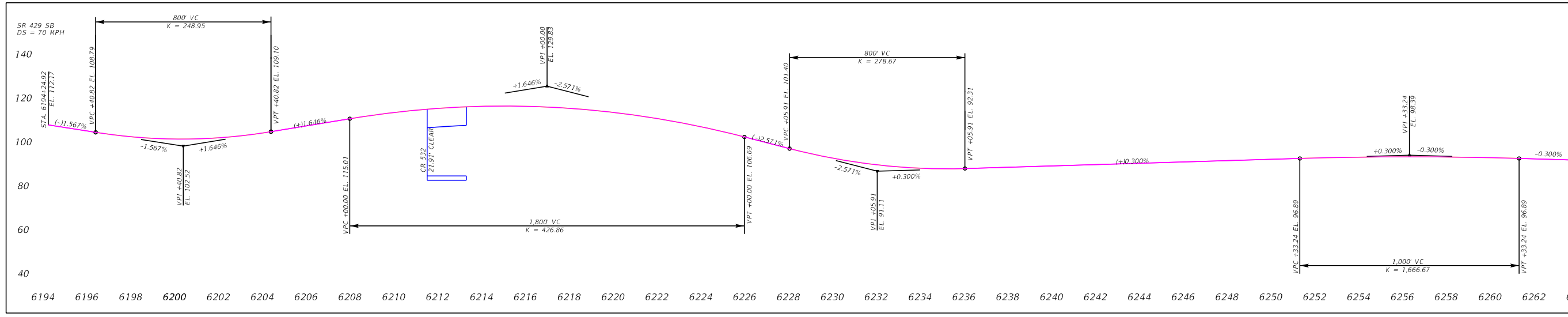
PROFILE SHEET (06)

FAC NOTE

MATCHLINE 429 NB STA. 7406+70



MATCHLINE 429 SB STA. 6263+68



**PREFERRED ALTERNATIVE**  
INTERSTATE 4 AT SR 429

**FDOT** POINCIANA PKWY EXT FROM CRS32 TO N OF I-4/SR429 INTERCHANGE PD&E  
FINANCIAL PROJECT ID NUMBER: 446581-1-22-01  
OSCEOLA COUNTY, FLORIDA

SR 429 NORTHBOUND AND SOUTHBOUND

1/24/2023 4:42:34 PM Chris.Davidson C:\pwwork\1\sh\_pwwork\user\0019471\PROFRD\_2\_01.dgn

REVISIONS		ENGINEER OF RECORD		STATE OF FLORIDA DEPARTMENT OF TRANSPORTATION			SHEET NO.
DATE	DESCRIPTION	DATE	DESCRIPTION	ROAD NO.	COUNTY	FINANCIAL PROJECT ID	
				SR 429	OSCEOLA & POLK	446581-1-22-01	

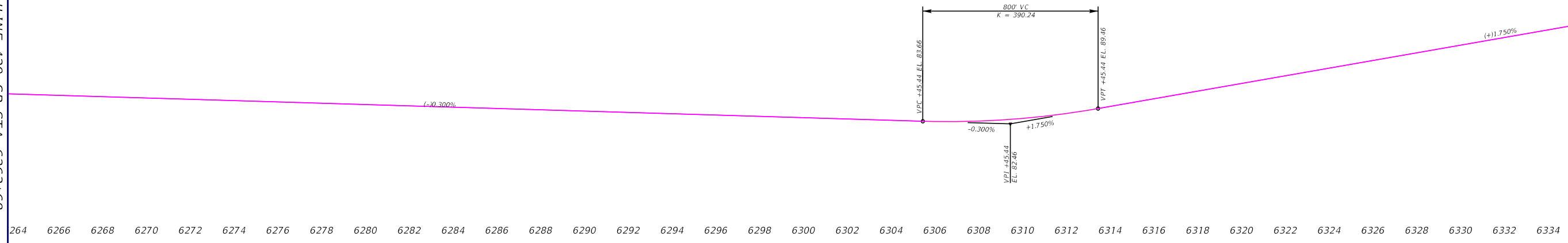
PROFILE SHEET (07)

FAC NOTE

SR 429 SB  
DS = 70 MPH

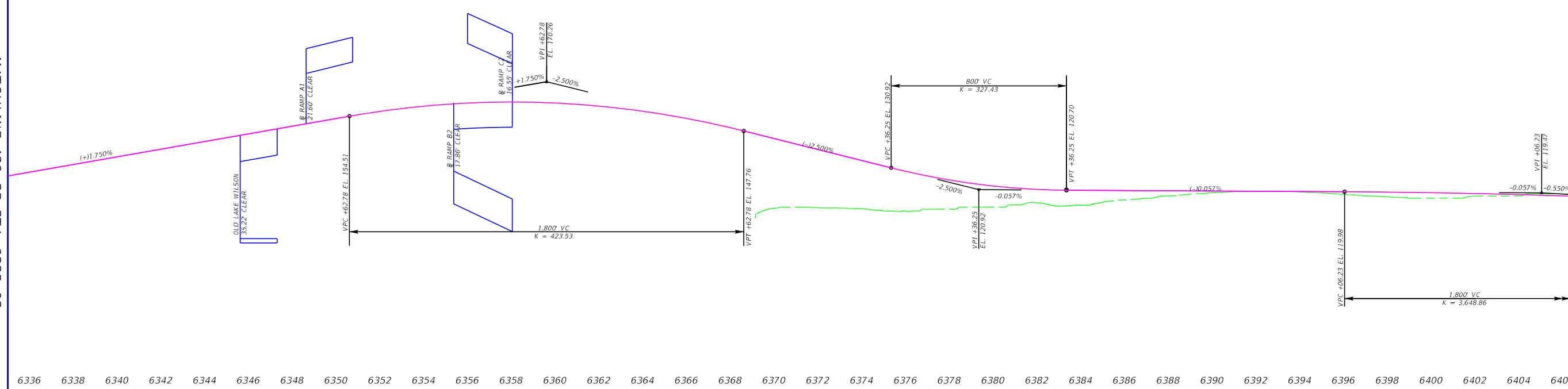
MATCHLINE 429\_SB STA. 6263+68

MATCHLINE 429\_SB STA. 6335+03



MATCHLINE 429\_SB STA. 6335+03

MATCHLINE 429\_SB STA. 6406+38



**PREFERRED ALTERNATIVE**  
INTERSTATE 4 AT SR 429

**FDOT** POINCIANA PKWY EXT FROM CRS32 TO N OF I-4/SR429 INTERCHANGE PD&E  
FINANCIAL PROJECT ID NUMBER: 446581-1-22-01  
OSCEOLA COUNTY, FLORIDA

SR 429 SOUTHBOUND

PROFILE SHEET (08)

1/24/2023 4:53:28 PM Chris.Davidson C:\pwwork\1\sh\_pwwork\user\0019471\PROFRD\_2\_01.dgn

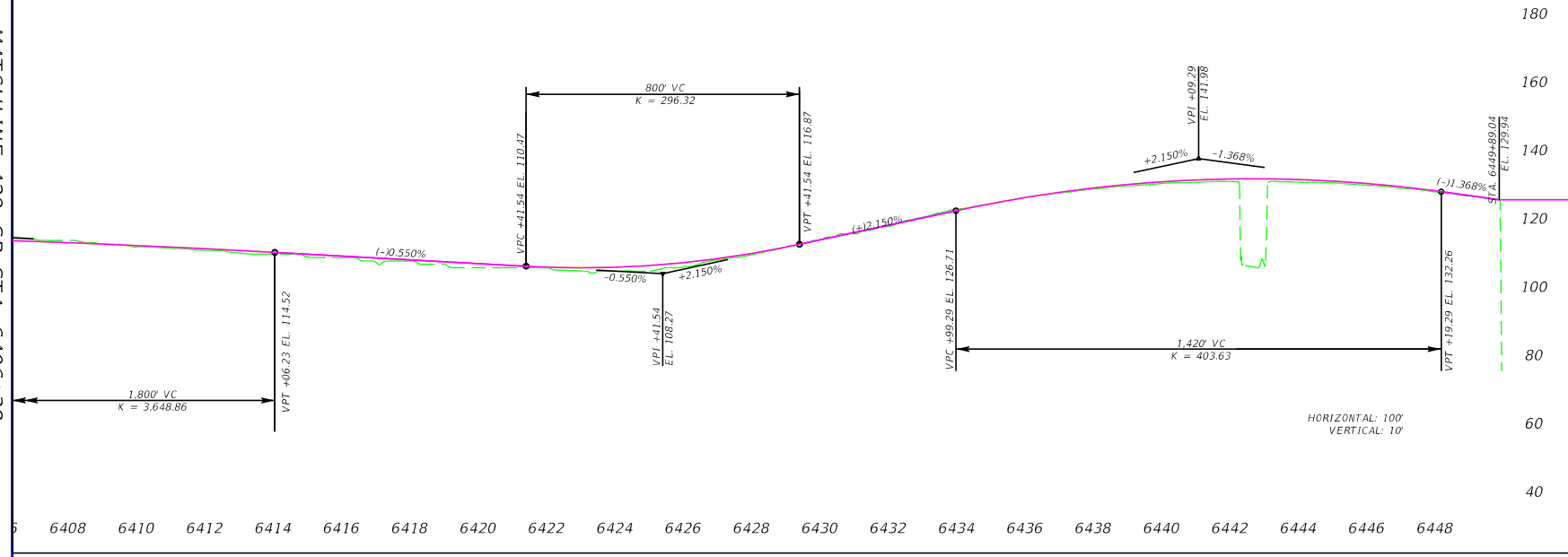
REVISIONS		ENGINEER OF RECORD		STATE OF FLORIDA DEPARTMENT OF TRANSPORTATION			SHEET NO.
DATE	DESCRIPTION	DATE	DESCRIPTION	ROAD NO.	COUNTY	FINANCIAL PROJECT ID	
				SR 429	OSCEOLA & POLK	446581-1-22-01	

RAMON F. BRETON  
LICENSE NUMBER: 53139  
KIMLEY-HORN AND ASSOCIATES, INC.  
189 S ORANGE AVE. SUITE 1000  
ORLANDO, FL 32801

FAC NOTE

SR 429 SB  
DS = 70 MPH

MATCHLINE 429 SB STA. 6406+38



**PREFERRED ALTERNATIVE**  
INTERSTATE 4 AT SR 429

**FDOT** POINCIANA PKWY EXT FROM CRS32 TO N OF I-4/SR429 INTERCHANGE PD&E  
FINANCIAL PROJECT ID NUMBER: 446581-1-22-01  
OSCEOLA COUNTY, FLORIDA

SR 429 SOUTHBOUND

PROFILE SHEET (09)

1/19/2023 4:07:52 PM Chris.Davidson  
C:\pwworking\sh\_pwworking\user\0019471\PROFRD\_2\_01.dgn

REVISIONS		ENGINEER OF RECORD		STATE OF FLORIDA DEPARTMENT OF TRANSPORTATION			SHEET NO.
DATE	DESCRIPTION	DATE	DESCRIPTION	ROAD NO.	COUNTY	FINANCIAL PROJECT ID	
				SR 429	OSCEOLA & POLK	446581-1-22-01	

FAC NOTE



## APPENDIX E

# Long Range Estimates (LRE) Summary for the Preferred Alternative

# FDOT Long Range Estimating System - Production

## R3: Project Details by Sequence Report

**Project:** 446581-1-22-01

**Letting Date:** 01/2099

**Description:** PD&E FOR POINCIANA PKWY EXT FROM CR532 TO N OF I-4/SR429 INTCHG

**District:** 08      **County:** 92 OSCEOLA

**Market Area:** 08      **Units:** English

**Contract Class:** 3      **Lump Sum Project:** N

**Design/Build:** N      **Project Length:** 4.000 MI

**Project Manager:** UNDERWOOD

**Version 12 Project Grand Total**

**\$1,273,562,069.39**

**Description:** Copy from V-11: Preferred Alternative: Poinciana Parkway Extension from CR 532 to N of I-4/SR 429 Interchange

**Sequence:** 1 NDR - New Construction, Divided, Rural

**Net Length:** 0.360 MI  
1,901 LF

**Description:** SR 538 Mainline NB and SB 6-Lane Divided. Includes bridges 538-1 and 538-2 and all Retention Basins.

### EARTHWORK COMPONENT

**User Input Data**

Description	Value
Standard Clearing and Grubbing Limits L/R	167.00 / 167.00
Incidental Clearing and Grubbing Area	0.00
Alignment Number	1
Distance	0.360
Top of Structural Course For Begin Section	105.00
Top of Structural Course For End Section	131.00
Horizontal Elevation For Begin Section	100.00
Horizontal Elevation For End Section	100.00
Front Slope L/R	1 to 1 / 1 to 1
Median Slope L/R	1 to 1 / 1 to 1
Median Shoulder Cross Slope L/R	5.00 % / 5.00 %
Outside Shoulder Cross Slope L/R	6.00 % / 6.00 %
Roadway Cross Slope L/R	2.00 % / 2.00 %

**Pay Items**

Pay item	Description	Quantity Unit	Unit Price	Extended Amount
110-1-1	CLEARING & GRUBBING	14.57 AC	\$21,000.00	\$305,970.00
120-6	EMBANKMENT	229,005.57 CY	\$20.88	\$4,781,636.30
<b>Earthwork Component Total</b>				<b>\$5,087,606.30</b>

### ROADWAY COMPONENT

**User Input Data**

Description	Value
Number of Lanes	6
Roadway Pavement Width L/R	36.00 / 36.00
Structural Spread Rate	440
Friction Course Spread Rate	80

**Pay Items**

Pay item	Description	Quantity Unit	Unit Price	Extended Amount
160-4	TYPE B STABILIZATION	25,344.00 SY	\$11.66	\$295,511.04
285-712	OPTIONAL BASE,BASE GROUP 12	15,485.18 SY	\$73.16	\$1,132,895.77
334-1-13	SUPERPAVE ASPHALTIC CONC, TRAFFIC C	3,345.41 TN	\$126.72	\$423,930.36
337-7-25	ASPH CONC FC,INC BIT,FC- 5,PG76-22	608.26 TN	\$159.94	\$97,285.10

**X-Items**

Pay item	Description	Quantity Unit	Unit Price	Extended Amount
546-72-1	GROUND-IN RUMBLE STRIPS, 16"	1.44 GM	\$881.71	\$1,269.66

**Pavement Marking Subcomponent**

Description	Value
Include Thermo/Tape/Other	Y
Pavement Type	Asphalt
Solid Stripe No. of Paint Applications	1
Solid Stripe No. of Stripes	4
Skip Stripe No. of Paint Applications	1
Skip Stripe No. of Stripes	4

**Pay Items**

Pay item	Description	Quantity Unit	Unit Price	Extended Amount
706-1-1	RAISED PAVMT MARK, TYPE B W/O FINAL SURF	243.00 EA	\$3.58	\$869.94
710-11-101	PAINTED PAVT MARK,STD,WHITE,SOLID,6"	1.44 GM	\$1,080.33	\$1,555.68
710-11-131	PAINTED PAVT MARK,STD,WHITE,SKIP, 6"	1.44 GM	\$460.80	\$663.55
711-15-101	THERMOPLASTIC, STD-OP, WHITE, SOLID, 6"	1.44 GM	\$4,966.76	\$7,152.13
711-15-131	THERMOPLASTIC, STD-OP, WHITE, SKIP, 6"	1.44 GM	\$1,845.33	\$2,657.28
711-15-201	THERMOPLASTIC, STD- OP,YELLOW, SOLID, 6"	1.44 GM	\$4,988.35	\$7,183.22

**Peripherals Subcomponent**

Description	Value
Off Road Bike Path(s)	0
Off Road Bike Path Width L/R	0.00 / 0.00
Bike Path Structural Spread Rate	0
Noise Barrier Wall Length	0.00
Noise Barrier Wall Begin Height	0.00
Noise Barrier Wall End Height	0.00

**Pay Items**

Pay item	Description	Quantity Unit	Unit Price	Extended Amount
550-10-120	FENCING, TYPE A, 5.1-6.0, STANDARD	4,223.00 LF	\$9.26	\$39,104.98

**Roadway Component Total** \$2,010,078.71

**SHOULDER COMPONENT**

**User Input Data**

Description	Value
Total Outside Shoulder Width L/R	12.00 / 12.00

Total Outside Shoulder Perf. Turf Width L/R	0.00 / 0.00
Paved Outside Shoulder Width L/R	12.00 / 12.00
Structural Spread Rate	220
Friction Course Spread Rate	80
Total Width (T) / 8" Overlap (O)	O
Rumble Strips 1/2 No. of Sides	2

#### Pay Items

Pay item	Description	Quantity Unit	Unit Price	Extended Amount
285-705	OPTIONAL BASE,BASE GROUP 05	5,208.19 SY	\$40.53	\$211,087.94
334-1-13	SUPERPAVE ASPHALTIC CONC, TRAFFIC C	557.57 TN	\$126.72	\$70,655.27
337-7-25	ASPH CONC FC,INC BIT,FC- 5,PG76-22	11.15 TN	\$159.94	\$1,783.33
546-72-1	GROUND-IN RUMBLE STRIPS, 16"	0.72 GM	\$881.71	\$634.83

#### X-Items

Pay item	Description	Quantity Unit	Unit Price	Extended Amount
521-8-7	CONC BARRIER, W/JUNCT SL, 36 SS	2,072.00 LF	\$303.07	\$627,961.04

**Comment:** Barrier wall for retaining wall sections

#### Erosion Control

##### Pay Items

Pay item	Description	Quantity Unit	Unit Price	Extended Amount
104-10-3	SEDIMENT BARRIER	4,942.08 LF	\$1.20	\$5,930.50
104-11	FLOATING TURBIDITY BARRIER	90.00 LF	\$9.49	\$854.10
104-12	STAKED TURBIDITY BARRIER- NYL REINF PVC	90.00 LF	\$4.44	\$399.60
104-15	SOIL TRACKING PREVENTION DEVICE	1.00 EA	\$2,988.11	\$2,988.11
104-18	INLET PROTECTION SYSTEM	6.00 EA	\$88.37	\$530.22
107-1	LITTER REMOVAL	8.73 AC	\$20.76	\$181.23
107-2	MOWING	8.73 AC	\$46.89	\$409.35

**Shoulder Component Total**

\$923,415.52

### MEDIAN COMPONENT

#### User Input Data

Description	Value
Total Median Width	74.00
Performance Turf Width	50.00
Total Median Shoulder Width L/R	12.00 / 12.00
Paved Median Shoulder Width L/R	12.00 / 12.00
Structural Spread Rate	220
Friction Course Spread Rate	80
Total Width (T) / 8" Overlap (O)	O
Rumble Strips 1/2 No. of Sides	2

#### Pay Items

Pay item	Description	Quantity Unit	Unit Price	Extended Amount
285-705	OPTIONAL BASE,BASE GROUP 05	5,208.19 SY	\$40.53	\$211,087.94
334-1-13	SUPERPAVE ASPHALTIC CONC, TRAFFIC C	557.57 TN	\$126.72	\$70,655.27
337-7-25	ASPH CONC FC,INC BIT,FC- 5,PG76-22	11.15 TN	\$159.94	\$1,783.33

521-8-7	CONC BARRIER, W/JUNCT SL, 36 SS	2,335.96 LF	\$303.07	\$707,959.40
546-72-1	GROUND-IN RUMBLE STRIPS, 16"	1.00 GM	\$881.71	\$881.71
570-1-2	PERFORMANCE TURF, SOD	10,560.00 SY	\$4.09	\$43,190.40
<b>Median Component Total</b>				<b>\$1,035,558.05</b>

#### DRAINAGE COMPONENT

##### Pay Items

Pay item	Description	Quantity Unit	Unit Price	Extended Amount
430-174-124	PIPE CULV, OPT MATL, ROUND, 24"SD	288.00 LF	\$126.21	\$36,348.48
430-175-124	PIPE CULV, OPT MATL, ROUND, 24"S/CD	128.00 LF	\$128.82	\$16,488.96
430-175-136	PIPE CULV, OPT MATL, ROUND, 36"S/CD	112.00 LF	\$342.26	\$38,333.12
430-984-129	MITERED END SECT, OPTIONAL RD, 24" SD	4.00 EA	\$2,253.96	\$9,015.84
524-1-1	CONCRETE DITCH PAVT, NR, 3"	720.00 SY	\$218.44	\$157,276.80
570-1-2	PERFORMANCE TURF, SOD	253.44 SY	\$4.09	\$1,036.57

##### X-Items

Pay item	Description	Quantity Unit	Unit Price	Extended Amount
425-1-921	INLETS, ADJACENT BARRIER, <=10' <b>Comment:</b> Estimated for Vertical Drain.	7.00 EA	\$5,906.88	\$41,348.16
425-1-922	INLETS, ADJACENT BARRIER, >10' <b>Comment:</b> Estimated for Vertical Drain.	6.00 EA	\$9,281.70	\$55,690.20

##### Retention Basin 1

Description	Value
Size	20 AC
Multiplier	3
Depth	4.00
Description	I-4/SR 429 Interchange Pond

##### Pay Items

Pay item	Description	Quantity Unit	Unit Price	Extended Amount
110-1-1	CLEARING & GRUBBING	60.00 AC	\$21,000.00	\$1,260,000.00
120-1	REGULAR EXCAVATION	387,200.01 CY	\$14.94	\$5,784,768.15
425-1-541	INLETS, DT BOT, TYPE D, <10'	9.00 EA	\$4,336.41	\$39,027.69
425-2-71	MANHOLES, J-7, <10'	9.00 EA	\$8,526.15	\$76,735.35
430-175-142	PIPE CULV, OPT MATL, ROUND, 42"S/CD	456.00 LF	\$525.91	\$239,814.96
430-175-160	PIPE CULV, OPT MATL, ROUND, 60"S/CD	1,800.00 LF	\$375.30	\$675,540.00
550-10-220	FENCING, TYPE B, 5.1-6.0', STANDARD	13,260.00 LF	\$23.47	\$311,212.20
550-60-234	FENCE GATE, TYP B, SLIDE/CANT, 18.1-20' OPEN	18.00 EA	\$3,027.61	\$54,496.98
570-1-1	PERFORMANCE TURF	290,400.00 SY	\$3.19	\$926,376.00

##### Retention Basin 2

Description	Value
Size	10 AC



Multiplier 2  
 Depth 4.00  
 Description Basin 2. Based on Study  
 Alignment 2A: Basin 2A-1\_2

**Pay Items**

Pay item	Description	Quantity	Unit	Unit Price	Extended Amount
110-1-1	CLEARING & GRUBBING	20.00	AC	\$21,000.00	\$420,000.00
120-1	REGULAR EXCAVATION	129,066.66	CY	\$14.94	\$1,928,255.90
425-1-541	INLETS, DT BOT, TYPE D, <10'	4.00	EA	\$4,336.41	\$17,345.64
425-2-71	MANHOLES, J-7, <10'	4.00	EA	\$8,526.15	\$34,104.60
430-175-142	PIPE CULV, OPT MATL, ROUND, 42"S/CD	208.00	LF	\$525.91	\$109,389.28
430-175-160	PIPE CULV, OPT MATL, ROUND, 60"S/CD	800.00	LF	\$375.30	\$300,240.00
550-10-220	FENCING, TYPE B, 5.1-6.0', STANDARD	5,560.00	LF	\$23.47	\$130,493.20
550-60-234	FENCE GATE, TYP B, SLIDE/CANT, 18.1-20' OPEN	6.00	EA	\$3,027.61	\$18,165.66
570-1-1	PERFORMANCE TURF	96,800.00	SY	\$3.19	\$308,792.00

**Retention Basin 3**

Description  
 Size 5 AC  
 Multiplier 2  
 Depth 4.00  
 Description Basin 3. Based on Study  
 Alignment 2A: Basin 2A-1\_3

**Pay Items**

Pay item	Description	Quantity	Unit	Unit Price	Extended Amount
110-1-1	CLEARING & GRUBBING	10.00	AC	\$21,000.00	\$210,000.00
120-1	REGULAR EXCAVATION	64,533.34	CY	\$14.94	\$964,128.10
425-1-541	INLETS, DT BOT, TYPE D, <10'	2.00	EA	\$4,336.41	\$8,672.82
425-2-71	MANHOLES, J-7, <10'	4.00	EA	\$8,526.15	\$34,104.60
430-175-142	PIPE CULV, OPT MATL, ROUND, 42"S/CD	112.00	LF	\$525.91	\$58,901.92
430-175-160	PIPE CULV, OPT MATL, ROUND, 60"S/CD	800.00	LF	\$375.30	\$300,240.00
550-10-220	FENCING, TYPE B, 5.1-6.0', STANDARD	3,720.00	LF	\$23.47	\$87,308.40
550-60-234	FENCE GATE, TYP B, SLIDE/CANT, 18.1-20' OPEN	4.00	EA	\$3,027.61	\$12,110.44
570-1-1	PERFORMANCE TURF	48,400.00	SY	\$3.19	\$154,396.00

**Retention Basin 4**

Description  
 Size 10 AC  
 Multiplier 2  
 Depth 4.00  
 Description Basin 4. Based on Study  
 Alignment 2A: Basin 2A-1\_4

**Pay Items**

Pay item	Description	Quantity	Unit	Unit Price	Extended Amount
110-1-1	CLEARING & GRUBBING	20.00	AC	\$21,000.00	\$420,000.00
120-1	REGULAR EXCAVATION	129,066.66	CY	\$14.94	\$1,928,255.90

425-1-541	INLETS, DT BOT, TYPE D, <10'	4.00 EA	\$4,336.41	\$17,345.64
425-2-71	MANHOLES, J-7, <10'	4.00 EA	\$8,526.15	\$34,104.60
430-175-142	PIPE CULV, OPT MATL, ROUND, 42"S/CD	208.00 LF	\$525.91	\$109,389.28
430-175-160	PIPE CULV, OPT MATL, ROUND, 60"S/CD	800.00 LF	\$375.30	\$300,240.00
550-10-220	FENCING, TYPE B, 5.1-6.0', STANDARD	5,560.00 LF	\$23.47	\$130,493.20
550-60-234	FENCE GATE, TYP B, SLIDE/CANT, 18.1-20' OPEN	6.00 EA	\$3,027.61	\$18,165.66
570-1-1	PERFORMANCE TURF	96,800.00 SY	\$3.19	\$308,792.00

**Retention Basin 5**

<b>Description</b>	<b>Value</b>
Size	5 AC
Multiplier	2
Depth	4.00
Description	Basin 5. Based on Study Alignment 2A: Basin 2A-1_5

**Pay Items**

Pay item	Description	Quantity Unit	Unit Price	Extended Amount
110-1-1	CLEARING & GRUBBING	10.00 AC	\$21,000.00	\$210,000.00
120-1	REGULAR EXCAVATION	64,533.34 CY	\$14.94	\$964,128.10
425-1-541	INLETS, DT BOT, TYPE D, <10'	2.00 EA	\$4,336.41	\$8,672.82
425-2-71	MANHOLES, J-7, <10'	4.00 EA	\$8,526.15	\$34,104.60
430-175-142	PIPE CULV, OPT MATL, ROUND, 42"S/CD	112.00 LF	\$525.91	\$58,901.92
430-175-160	PIPE CULV, OPT MATL, ROUND, 60"S/CD	800.00 LF	\$375.30	\$300,240.00
550-10-220	FENCING, TYPE B, 5.1-6.0', STANDARD	3,720.00 LF	\$23.47	\$87,308.40
550-60-234	FENCE GATE, TYP B, SLIDE/CANT, 18.1-20' OPEN	4.00 EA	\$3,027.61	\$12,110.44
570-1-1	PERFORMANCE TURF	48,400.00 SY	\$3.19	\$154,396.00

**Retention Basin 6**

<b>Description</b>	<b>Value</b>
Size	5 AC
Multiplier	2
Depth	4.00
Description	Basin 6. Based on Study Alignment 2A: Basin 2A-1_6

**Pay Items**

Pay item	Description	Quantity Unit	Unit Price	Extended Amount
110-1-1	CLEARING & GRUBBING	10.00 AC	\$21,000.00	\$210,000.00
120-1	REGULAR EXCAVATION	64,533.34 CY	\$14.94	\$964,128.10
425-1-541	INLETS, DT BOT, TYPE D, <10'	2.00 EA	\$4,336.41	\$8,672.82
425-2-71	MANHOLES, J-7, <10'	4.00 EA	\$8,526.15	\$34,104.60
430-175-142	PIPE CULV, OPT MATL, ROUND, 42"S/CD	112.00 LF	\$525.91	\$58,901.92
430-175-160	PIPE CULV, OPT MATL, ROUND, 60"S/CD	800.00 LF	\$375.30	\$300,240.00
550-10-220	FENCING, TYPE B, 5.1-6.0', STANDARD	3,720.00 LF	\$23.47	\$87,308.40
550-60-234	FENCE GATE, TYP B, SLIDE/CANT, 18.1-20' OPEN	4.00 EA	\$3,027.61	\$12,110.44

570-1-1	PERFORMANCE TURF	48,400.00 SY	\$3.19	\$154,396.00
---------	------------------	--------------	--------	--------------

**Retention Basin 7**

<b>Description</b>	<b>Value</b>
Size	2.5 AC
Multiplier	2
Depth	4.00
Description	Basin 7. Based on Study Alignment 2A: Basin 2A-1_7

**Pay Items**

Pay item	Description	Quantity Unit	Unit Price	Extended Amount
110-1-1	CLEARING & GRUBBING	5.00 AC	\$21,000.00	\$105,000.00
120-1	REGULAR EXCAVATION	32,266.66 CY	\$14.94	\$482,063.90
425-1-361	INLETS, CURB, TYPE P-6, <10'	2.00 EA	\$8,061.74	\$16,123.48
425-2-71	MANHOLES, J-7, <10'	2.00 EA	\$8,526.15	\$17,052.30
430-175-142	PIPE CULV, OPT MATL, ROUND, 42"S/CD	112.00 LF	\$525.91	\$58,901.92
430-175-160	PIPE CULV, OPT MATL, ROUND, 60"S/CD	400.00 LF	\$375.30	\$150,120.00
550-10-220	FENCING, TYPE B, 5.1-6.0', STANDARD	2,670.00 LF	\$23.47	\$62,664.90
550-60-234	FENCE GATE, TYP B, SLIDE/CANT, 18.1-20' OPEN	2.00 EA	\$3,027.61	\$6,055.22
570-1-1	PERFORMANCE TURF	24,200.00 SY	\$3.19	\$77,198.00

**Retention Basin 8**

<b>Description</b>	<b>Value</b>
Size	10 AC
Multiplier	2
Depth	4.00
Description	Basin 3 IC for CR 532 Interchange. Based on Study Alignment 2A: Basin 2A-1_3IC

**Pay Items**

Pay item	Description	Quantity Unit	Unit Price	Extended Amount
110-1-1	CLEARING & GRUBBING	20.00 AC	\$21,000.00	\$420,000.00
120-1	REGULAR EXCAVATION	129,066.66 CY	\$14.94	\$1,928,255.90
425-1-541	INLETS, DT BOT, TYPE D, <10'	4.00 EA	\$4,336.41	\$17,345.64
425-2-71	MANHOLES, J-7, <10'	4.00 EA	\$8,526.15	\$34,104.60
430-175-142	PIPE CULV, OPT MATL, ROUND, 42"S/CD	208.00 LF	\$525.91	\$109,389.28
430-175-160	PIPE CULV, OPT MATL, ROUND, 60"S/CD	800.00 LF	\$375.30	\$300,240.00
550-10-220	FENCING, TYPE B, 5.1-6.0', STANDARD	5,560.00 LF	\$23.47	\$130,493.20
550-60-234	FENCE GATE, TYP B, SLIDE/CANT, 18.1-20' OPEN	6.00 EA	\$3,027.61	\$18,165.66
570-1-1	PERFORMANCE TURF	96,800.00 SY	\$3.19	\$308,792.00

<b>Drainage Component Total</b>				\$25,988,634.86
---------------------------------	--	--	--	-----------------

**SIGNING COMPONENT**

**Pay Items**

Pay item	Description	Quantity Unit	Unit Price	Extended Amount
----------	-------------	---------------	------------	-----------------

700-1-11	SINGLE POST SIGN, F&I GM, <12 SF	1.00 AS	\$380.22	\$380.22
700-1-12	SINGLE POST SIGN, F&I GM, 12-20 SF	9.00 AS	\$1,503.18	\$13,528.62
700-2-14	MULTI- POST SIGN, F&I GM, 31-50 SF	1.00 AS	\$5,637.01	\$5,637.01
700-2-15	MULTI- POST SIGN, F&I GM, 51-100 SF	3.00 AS	\$7,713.11	\$23,139.33

**X-Items**

Pay item	Description	Quantity Unit	Unit Price	Extended Amount
700-4-114	OH STATIC SIGN STR, F&I, C 41-50 FT <b>Comment:</b> Cantilever Overhead Sign @0.33 mile including Bridges in sequence.	1.00 EA	\$94,981.18	\$94,981.18
700-4-127	OH STATIC SIGN STR, F&I, S 151-200 FT <b>Comment:</b> Span Overhead Sign @0.75 mile including Bridges in sequence.	1.00 EA	\$211,285.18	\$211,285.18
<b>Signing Component Total</b>				\$348,951.54

**INTELLIGENT TRAFFIC SYSTEM (ITS) COMPONENT**

**Description of Work**

General ITS per LF of roadway and Bridges in Sequence. Assume \$70/LF

**EX-Items**

Pay item	Description	Quantity Unit	Unit Price	Extended Amount
000-000	GENERAL ITS <b>Comment:</b> General ITS per LF of roadway and Bridges in Sequence. Assume \$70/LF	2,321.00 LF	\$70.00	\$162,470.00
<b>Intelligent Traffic System (ITS) Component Total</b>				\$162,470.00

**LIGHTING COMPONENT**

**Rural Lighting Subcomponent**

Description	Value			
Multiplier (Number of Poles)	23			
<b>Pay Items</b>				
Pay item	Description	Quantity Unit	Unit Price	Extended Amount
630-2-11	CONDUIT, F& I, OPEN TRENCH	4,600.00 LF	\$9.76	\$44,896.00
635-2-11	PULL & SPLICE BOX, F&I, 13" x 24"	23.00 EA	\$767.98	\$17,663.54
715-1-13	LIGHTING CONDUCTORS, F&I, INSUL, NO.4-2	13,800.00 LF	\$2.62	\$36,156.00
715-4-14	LIGHT POLE COMPLETE, F&I-STD, 45'	23.00 EA	\$7,063.23	\$162,454.29
715-500-1	POLE CABLE DIST SYS, CONVENTIONAL	23.00 EA	\$621.64	\$14,297.72
<b>Subcomponent Total</b>				\$275,467.55
<b>Lighting Component Total</b>				\$275,467.55

**LANDSCAPING COMPONENT**

User Input Data

<b>Description</b>	<b>Value</b>
Cost %	2.00
Component Detail	N

**Landscaping Component Total**

\$599,153.74

**BRIDGES COMPONENT**

**Bridge 538-1**

<b>Description</b>	<b>Value</b>
Estimate Type	SF Estimate
Primary Estimate	YES
Length (LF)	209.00
Width (LF)	63.00
Type	Overpass Bridge
Cost Factor	1.50
Structure No.	
Removal of Existing Structures area	0.00
Default Cost per SF	\$120.00
Factored Cost per SF	\$180.00
<b>Final Cost per SF</b>	<b>\$188.38</b>
<b>Basic Bridge Cost</b>	<b>\$2,370,060.00</b>

Description SOUTBOUND SR 538 OVER CR 532

**Bridge Pay Items**

Pay item	Description	Quantity Unit	Unit Price	Extended Amount
400-2-10	CONC CLASS II, APPROACH SLABS	140.00 CY	\$588.22	\$82,350.80
415-1-9	REINF STEEL- APPROACH SLABS	24,500.00 LB	\$1.14	\$27,930.00

**Bridge 538-1 Total** \$2,480,340.80

**Bridge 538-2**

<b>Description</b>	<b>Value</b>
Estimate Type	SF Estimate
Primary Estimate	YES
Length (LF)	210.00
Width (LF)	75.00
Type	Overpass Bridge
Cost Factor	1.50
Structure No.	
Removal of Existing Structures area	0.00
Default Cost per SF	\$120.00
Factored Cost per SF	\$180.00
<b>Final Cost per SF</b>	<b>\$188.34</b>
<b>Basic Bridge Cost</b>	<b>\$2,835,000.00</b>

Description NORTHBOUND SR 538 OVER CR 532

**Bridge Pay Items**

Pay item	Description	Quantity Unit	Unit Price	Extended Amount
400-2-10	CONC CLASS II, APPROACH SLABS	166.67 CY	\$588.22	\$98,038.63
415-1-9	REINF STEEL- APPROACH SLABS	29,167.25 LB	\$1.14	\$33,250.66

**Bridge 538-2 Total** \$2,966,289.30

**Bridges Component Total** \$5,446,630.10



---

**RETAINING WALLS COMPONENT**

**Retaining Wall 1**

<b>Description</b>	<b>Value</b>
Length	2,405.00
Begin height	17.50
End Height	17.50
Multiplier	2

**Pay Items**

<b>Pay item</b>	<b>Description</b>	<b>Quantity</b>	<b>Unit</b>	<b>Unit Price</b>	<b>Extended Amount</b>
548-12	RET WALL SYSTEM, PERM, EX BARRIER	84,175.00	SF	\$36.17	\$3,044,609.75
<b>Retaining Walls Component Total</b>					<b>\$3,044,609.76</b>

---

**Sequence 1 Total** **\$44,922,576.13**

---

Sequence: 2 NDR - New Construction, Divided, Rural

Net Length: 1.485 MI  
7,838 LF

Description: SR 538 Mainline 6-Lane Divided, Standard Shoulders. Noise Wall, Mainline Toll Plaza and DMS.

### EARTHWORK COMPONENT

#### User Input Data

Description	Value
Standard Clearing and Grubbing Limits L/R	167.00 / 167.00
Incidental Clearing and Grubbing Area	0.00
Alignment Number	1
Distance	1.485
Top of Structural Course For Begin Section	105.00
Top of Structural Course For End Section	105.00
Horizontal Elevation For Begin Section	100.00
Horizontal Elevation For End Section	100.00
Front Slope L/R	6 to 1 / 6 to 1
Median Slope L/R	6 to 1 / 6 to 1
Median Shoulder Cross Slope L/R	5.00 % / 5.00 %
Outside Shoulder Cross Slope L/R	6.00 % / 6.00 %
Roadway Cross Slope L/R	2.00 % / 2.00 %

#### Pay Items

Pay item	Description	Quantity Unit	Unit Price	Extended Amount
110-1-1	CLEARING & GRUBBING	60.08 AC	\$21,000.00	\$1,261,680.00
120-6	EMBANKMENT	197,413.92 CY	\$20.88	\$4,122,002.65
<b>Earthwork Component Total</b>				<b>\$5,383,682.65</b>

### ROADWAY COMPONENT

#### User Input Data

Description	Value
Number of Lanes	6
Roadway Pavement Width L/R	36.00 / 36.00
Structural Spread Rate	440
Friction Course Spread Rate	80

#### Pay Items

Pay item	Description	Quantity Unit	Unit Price	Extended Amount
160-4	TYPE B STABILIZATION	104,508.80 SY	\$11.66	\$1,218,572.61
285-712	OPTIONAL BASE,BASE GROUP 12	63,854.88 SY	\$73.16	\$4,671,623.02
334-1-13	SUPERPAVE ASPHALTIC CONC, TRAFFIC C	13,795.16 TN	\$126.72	\$1,748,122.68
337-7-25	ASPH CONC FC,INC BIT,FC- 5,PG76-22	2,508.21 TN	\$159.94	\$401,163.11

#### Pavement Marking Subcomponent

Description	Value
Include Thermo/Tape/Other	Y
Pavement Type	Asphalt
Solid Stripe No. of Paint Applications	1
Solid Stripe No. of Stripes	4
Skip Stripe No. of Paint Applications	1
Skip Stripe No. of Stripes	4

**Pay Items**

Pay item	Description	Quantity Unit	Unit Price	Extended Amount
706-1-1	RAISED PAVMT MARK, TYPE B W/O FINAL SURF	1,002.00 EA	\$3.58	\$3,587.16
710-11-101	PAINTED PAVT MARK,STD,WHITE,SOLID,6"	5.94 GM	\$1,080.33	\$6,417.16
710-11-131	PAINTED PAVT MARK,STD,WHITE,SKIP, 6"	5.94 GM	\$460.80	\$2,737.15
711-15-101	THERMOPLASTIC, STD-OP, WHITE, SOLID, 6"	5.94 GM	\$4,966.76	\$29,502.55
711-15-131	THERMOPLASTIC, STD-OP, WHITE, SKIP, 6"	5.94 GM	\$1,845.33	\$10,961.26
711-15-201	THERMOPLASTIC, STD-OP,YELLOW, SOLID, 6"	5.94 GM	\$4,988.35	\$29,630.80

**Peripherals Subcomponent**

Description	Value
Off Road Bike Path(s)	0
Off Road Bike Path Width L/R	0.00 / 0.00
Bike Path Structural Spread Rate	0
Noise Barrier Wall Length	1,216.00
Noise Barrier Wall Begin Height	20.00
Noise Barrier Wall End Height	20.00

**Pay Items**

Pay item	Description	Quantity Unit	Unit Price	Extended Amount
534-72-101	SOUND/NOISE BARRIER-INC FOUNDATION, PERM	24,320.00 SF	\$40.65	\$988,608.00
550-10-120	FENCING, TYPE A, 5.1-6.0, STANDARD	15,676.00 LF	\$9.26	\$145,159.76

**Roadway Component Total**

\$9,256,085.26

**SHOULDER COMPONENT****User Input Data**

Description	Value
Total Outside Shoulder Width L/R	12.00 / 12.00
Total Outside Shoulder Perf. Turf Width L/R	2.00 / 2.00
Paved Outside Shoulder Width L/R	10.00 / 10.00
Structural Spread Rate	220
Friction Course Spread Rate	80
Total Width (T) / 8" Overlap (O)	0
Rumble Strips 1/2No. of Sides	2

**Pay Items**

Pay item	Description	Quantity Unit	Unit Price	Extended Amount
285-705	OPTIONAL BASE,BASE GROUP 05	17,992.93 SY	\$40.53	\$729,253.45
334-1-13	SUPERPAVE ASPHALTIC CONC, TRAFFIC C	1,915.99 TN	\$126.72	\$242,794.25
337-7-25	ASPH CONC FC,INC BIT,FC-5,PG76-22	45.98 TN	\$159.94	\$7,354.04
546-72-1	GROUND-IN RUMBLE STRIPS, 16"	2.97 GM	\$881.71	\$2,618.68
570-1-1	PERFORMANCE TURF	3,483.63 SY	\$3.19	\$11,112.78

**Erosion Control**

**Pay Items**

Pay item	Description	Quantity Unit	Unit Price	Extended Amount
104-10-3	SEDIMENT BARRIER	20,379.22 LF	\$1.20	\$24,455.06
104-11	FLOATING TURBIDITY BARRIER	371.12 LF	\$9.49	\$3,521.93
104-12	STAKED TURBIDITY BARRIER- NYL REINF PVC	371.12 LF	\$4.44	\$1,647.77
104-15	SOIL TRACKING PREVENTION DEVICE	2.00 EA	\$2,988.11	\$5,976.22
104-18	INLET PROTECTION SYSTEM	9.00 EA	\$88.37	\$795.33
107-1	LITTER REMOVAL	35.98 AC	\$20.76	\$746.94
107-2	MOWING	35.98 AC	\$46.89	\$1,687.10
<b>Shoulder Component Total</b>				<b>\$1,031,963.55</b>

**MEDIAN COMPONENT****User Input Data**

Description	Value
Total Median Width	74.00
Performance Turf Width	54.00
Total Median Shoulder Width L/R	12.00 / 12.00
Paved Median Shoulder Width L/R	10.00 / 10.00
Structural Spread Rate	220
Friction Course Spread Rate	80
Total Width (T) / 8" Overlap (O)	O
Rumble Strips i; 1/2No. of Sides	2

**Pay Items**

Pay item	Description	Quantity Unit	Unit Price	Extended Amount
285-705	OPTIONAL BASE,BASE GROUP 05	17,992.93 SY	\$40.53	\$729,253.45
334-1-13	SUPERPAVE ASPHALTIC CONC, TRAFFIC C	1,915.99 TN	\$126.72	\$242,794.25
337-7-25	ASPH CONC FC,INC BIT,FC- 5,PG76-22	45.98 TN	\$159.94	\$7,354.04
546-72-1	GROUND-IN RUMBLE STRIPS, 16"	3.00 GM	\$881.71	\$2,645.13
570-1-2	PERFORMANCE TURF, SOD	47,028.96 SY	\$4.09	\$192,348.45
<b>Median Component Total</b>				<b>\$1,174,395.32</b>

**DRAINAGE COMPONENT****Pay Items**

Pay item	Description	Quantity Unit	Unit Price	Extended Amount
425-1-551	INLETS, DT BOT, TYPE E, <10'	9.00 EA	\$13,191.95	\$118,727.55
430-174-124	PIPE CULV, OPT MATL, ROUND,24"SD	1,192.00 LF	\$126.21	\$150,442.32
430-175-124	PIPE CULV, OPT MATL, ROUND, 24"S/CD	512.00 LF	\$128.82	\$65,955.84
430-175-136	PIPE CULV, OPT MATL, ROUND, 36"S/CD	440.00 LF	\$342.26	\$150,594.40
430-984-129	MITERED END SECT, OPTIONAL RD, 24" SD	60.00 EA	\$2,253.96	\$135,237.60
524-1-1	CONCRETE DITCH PAVT, NR, 3"	2,969.00 SY	\$218.44	\$648,548.36
570-1-1	PERFORMANCE TURF	1,045.09 SY	\$3.19	\$3,333.84

Drainage Component Total

\$1,272,839.91

**SIGNING COMPONENT**

**Pay Items**

Pay item	Description	Quantity Unit	Unit Price	Extended Amount
700-1-11	SINGLE POST SIGN, F&I GM, <12 SF	3.00 AS	\$380.22	\$1,140.66
700-1-12	SINGLE POST SIGN, F&I GM, 12-20 SF	36.00 AS	\$1,503.18	\$54,114.48
700-2-14	MULTI- POST SIGN, F&I GM, 31-50 SF	3.00 AS	\$5,637.01	\$16,911.03
700-2-15	MULTI- POST SIGN, F&I GM, 51-100 SF	9.00 AS	\$7,713.11	\$69,417.99

**X-Items**

Pay item	Description	Quantity Unit	Unit Price	Extended Amount
700-4-114	OH STATIC SIGN STR, F&I, C 41-50 FT	5.00 EA	\$94,981.18	\$474,905.90
700-4-127	OH STATIC SIGN STR, F&I, S 151-200 FT	2.00 EA	\$211,285.18	\$422,570.36

**Signing Component Total**

\$1,039,060.42

**INTELLIGENT TRAFFIC SYSTEM (ITS) COMPONENT**

**Description of Work**

General ITS per LF of roadway. Assume \$70/LF

**EX-Items**

Pay item	Description	Quantity Unit	Unit Price	Extended Amount
000-000	GENERAL ITS	7,838.00 LF	\$70.00	\$548,660.00
	<b>Comment:</b> General ITS per LF of roadway. Assume \$70/LF			

**Intelligent Traffic System (ITS) Component Total**

\$548,660.00

**LIGHTING COMPONENT**

**Rural Lighting Subcomponent**

**Description**

Multiplier (Number of Poles)

**Value**

83

**Pay Items**

Pay item	Description	Quantity Unit	Unit Price	Extended Amount
630-2-11	CONDUIT, F& I, OPEN TRENCH	16,600.00 LF	\$9.76	\$162,016.00
635-2-11	PULL & SPLICE BOX, F&I, 13" x 24"	83.00 EA	\$767.98	\$63,742.34
715-1-13	LIGHTING CONDUCTORS, F&I, INSUL, NO.4-2	49,800.00 LF	\$2.62	\$130,476.00
715-4-14	LIGHT POLE COMPLETE, F&I-STD, 45'	83.00 EA	\$7,063.23	\$586,248.09
715-500-1	POLE CABLE DIST SYS, CONVENTIONAL	83.00 EA	\$621.64	\$51,596.12
	<b>Subcomponent Total</b>			\$994,078.55

**Lighting Component Total**

\$994,078.55



**LANDSCAPING COMPONENT**

**User Input Data**

<b>Description</b>	<b>Value</b>
Cost %	2.00
Component Detail	N

---

**Landscaping Component Total** \$254,705.68

---

**ARCHITECTURAL COMPONENT**

**EX-Items**

<b>Pay item</b>	<b>Description</b>	<b>Quantity</b>	<b>Unit</b>	<b>Unit Price</b>	<b>Extended Amount</b>
735-000	SR 538 MAINLINE TOLL PLAZA	1.00	LS	\$5,000,000.00	\$5,000,000.00
	<b>Comment:</b> SR 538 Mainline Toll Plaza				

---

**Architectural Component Total** \$5,000,000.00

---

**Sequence 2 Total** \$25,955,471.34

---

Sequence: 3 NDR - New Construction, Divided, Rural

Net Length: 0.750 MI  
3,960 LF

Description: SR 538 Mainline 6-Lane Divided (SB Only/NB Included in Bridge), Retaining Wall. 3 Lane SB.  
Bridges 538-3, 538-4, 538-4A, 538-5.

### EARTHWORK COMPONENT

#### User Input Data

Description	Value
Standard Clearing and Grubbing Limits L/R	161.00 / 161.00
Incidental Clearing and Grubbing Area	0.00
Alignment Number	1
Distance	0.750
Top of Structural Course For Begin Section	105.00
Top of Structural Course For End Section	131.00
Horizontal Elevation For Begin Section	100.00
Horizontal Elevation For End Section	100.00
Front Slope L/R	1 to 1 / 1 to 1
Median Slope L/R	1 to 1 / 1 to 1
Median Shoulder Cross Slope L/R	5.00 % / 5.00 %
Outside Shoulder Cross Slope L/R	6.00 % / 6.00 %
Roadway Cross Slope L/R	2.00 % / 2.00 %

#### Pay Items

Pay item	Description	Quantity	Unit	Unit Price	Extended Amount
110-1-1	CLEARING & GRUBBING	29.27	AC	\$21,000.00	\$614,670.00
120-6	EMBANKMENT	202,357.47	CY	\$20.88	\$4,225,223.97
<b>Earthwork Component Total</b>					<b>\$4,839,893.97</b>

### ROADWAY COMPONENT

#### User Input Data

Description	Value
Number of Lanes	3
Roadway Pavement Width L/R	36.00 / 0.00
Structural Spread Rate	440
Friction Course Spread Rate	80

#### Pay Items

Pay item	Description	Quantity	Unit	Unit Price	Extended Amount
160-4	TYPE B STABILIZATION	26,400.00	SY	\$11.66	\$307,824.00
285-712	OPTIONAL BASE,BASE GROUP 12	16,130.40	SY	\$73.16	\$1,180,100.06
334-1-13	SUPERPAVE ASPHALTIC CONC, TRAFFIC C	3,484.80	TN	\$126.72	\$441,593.86
337-7-25	ASPH CONC FC,INC BIT,FC- 5,PG76-22	633.60	TN	\$159.94	\$101,337.98

#### Pavement Marking Subcomponent

Description	Value
Include Thermo/Tape/Other	Y
Pavement Type	Asphalt
Solid Stripe No. of Paint Applications	1
Solid Stripe No. of Stripes	4
Skip Stripe No. of Paint Applications	1
Skip Stripe No. of Stripes	1

**Pay Items**

Pay item	Description	Quantity Unit	Unit Price	Extended Amount
706-1-1	RAISED PAVMT MARK, TYPE B W/O FINAL SURF	202.00 EA	\$3.58	\$723.16
710-11-101	PAINTED PAVT MARK,STD,WHITE,SOLID,6"	3.00 GM	\$1,080.33	\$3,240.99
710-11-131	PAINTED PAVT MARK,STD,WHITE,SKIP, 6"	0.75 GM	\$460.80	\$345.60
711-15-101	THERMOPLASTIC, STD-OP, WHITE, SOLID, 6"	3.00 GM	\$4,966.76	\$14,900.28
711-15-131	THERMOPLASTIC, STD-OP, WHITE, SKIP, 6"	0.75 GM	\$1,845.33	\$1,384.00
711-15-201	THERMOPLASTIC, STD-OP,YELLOW, SOLID, 6"	3.00 GM	\$4,988.35	\$14,965.05

**Peripherals Subcomponent**

Description	Value
Off Road Bike Path(s)	0
Off Road Bike Path Width L/R	0.00 / 0.00
Bike Path Structural Spread Rate	0
Noise Barrier Wall Length	0.00
Noise Barrier Wall Begin Height	0.00
Noise Barrier Wall End Height	0.00

**Pay Items**

Pay item	Description	Quantity Unit	Unit Price	Extended Amount
521-72-40	SHLDR CONC BARRIER,38" OR 44" HEIGHT	4,684.00 LF	\$306.25	\$1,434,475.00
550-10-120	FENCING, TYPE A, 5.1-6.0, STANDARD	9,192.00 LF	\$9.26	\$85,117.92
<b>Roadway Component Total</b>				<b>\$3,586,007.90</b>

**SHOULDER COMPONENT****User Input Data**

Description	Value
Total Outside Shoulder Width L/R	12.00 / 0.00
Total Outside Shoulder Perf. Turf Width L/R	0.00 / 0.00
Paved Outside Shoulder Width L/R	12.00 / 0.00
Structural Spread Rate	220
Friction Course Spread Rate	80
Total Width (T) / 8" Overlap (O)	0
Rumble Strips $\bar{i}$ $\frac{1}{2}$ No. of Sides	2

**Pay Items**

Pay item	Description	Quantity Unit	Unit Price	Extended Amount
285-705	OPTIONAL BASE,BASE GROUP 05	5,425.20 SY	\$40.53	\$219,883.36
334-1-13	SUPERPAVE ASPHALTIC CONC, TRAFFIC C	580.80 TN	\$126.72	\$73,598.98
337-7-25	ASPH CONC FC,INC BIT,FC-5,PG76-22	11.62 TN	\$159.94	\$1,858.50
546-72-1	GROUND-IN RUMBLE STRIPS, 16"	1.50 GM	\$881.71	\$1,322.56

**X-Items**

Pay item	Description	Quantity Unit	Unit Price	Extended Amount
521-8-7	CONC BARRIER, W/JUNCT SL, 36 SS	800.00 LF	\$303.07	\$242,456.00
<b>Comment:</b> Barrier Wall For Retaining Wall Sections				

### Erosion Control

#### Pay Items

Pay item	Description	Quantity Unit	Unit Price	Extended Amount
104-10-3	SEDIMENT BARRIER	10,296.00 LF	\$1.20	\$12,355.20
104-11	FLOATING TURBIDITY BARRIER	187.50 LF	\$9.49	\$1,779.38
104-12	STAKED TURBIDITY BARRIER-NYL REINF PVC	187.50 LF	\$4.44	\$832.50
104-15	SOIL TRACKING PREVENTION DEVICE	1.00 EA	\$2,988.11	\$2,988.11
104-18	INLET PROTECTION SYSTEM	5.00 EA	\$88.37	\$441.85
107-1	LITTER REMOVAL	18.18 AC	\$20.76	\$377.42
107-2	MOWING	18.18 AC	\$46.89	\$852.46
<b>Shoulder Component Total</b>				<b>\$558,746.33</b>

### MEDIAN COMPONENT

#### User Input Data

Description	Value
Total Median Width	44.00
Performance Turf Width	17.00
Total Median Shoulder Width L/R	12.00 / 0.00
Paved Median Shoulder Width L/R	12.00 / 0.00
Structural Spread Rate	220
Friction Course Spread Rate	80
Total Width (T) / 8" Overlap (O)	O
Rumble Strips i; ½No. of Sides	2

#### Pay Items

Pay item	Description	Quantity Unit	Unit Price	Extended Amount
285-705	OPTIONAL BASE,BASE GROUP 05	5,425.20 SY	\$40.53	\$219,883.36
334-1-13	SUPERPAVE ASPHALTIC CONC, TRAFFIC C	580.80 TN	\$126.72	\$73,598.98
337-7-25	ASPH CONC FC,INC BIT,FC-5,PG76-22	11.62 TN	\$159.94	\$1,858.50
521-8-7	CONC BARRIER, W/JUNCT SL, 36 SS	6,570.27 LF	\$303.07	\$1,991,251.73
546-72-1	GROUND-IN RUMBLE STRIPS, 16"	2.00 GM	\$881.71	\$1,763.42
570-1-2	PERFORMANCE TURF, SOD	7,480.00 SY	\$4.09	\$30,593.20
<b>Median Component Total</b>				<b>\$2,318,949.19</b>

### DRAINAGE COMPONENT

#### Pay Items

Pay item	Description	Quantity Unit	Unit Price	Extended Amount
425-1-551	INLETS, DT BOT, TYPE E, <10'	5.00 EA	\$13,191.95	\$65,959.75
430-174-124	PIPE CULV, OPT MATL, ROUND,24"SD	600.00 LF	\$126.21	\$75,726.00

430-175-124	PIPE CULV, OPT MATL, ROUND, 24"S/CD	264.00 LF	\$128.82	\$34,008.48
430-175-136	PIPE CULV, OPT MATL, ROUND, 36"S/CD	224.00 LF	\$342.26	\$76,666.24
430-984-129	MITERED END SECT, OPTIONAL RD, 24" SD	30.00 EA	\$2,253.96	\$67,618.80
524-1-1	CONCRETE DITCH PAVT, NR, 3"	1,500.00 SY	\$218.44	\$327,660.00
570-1-1	PERFORMANCE TURF	528.00 SY	\$3.19	\$1,684.32

**X-Items**

Pay item	Description	Quantity Unit	Unit Price	Extended Amount
425-1-921	INLETS, ADJACENT BARRIER, <=10'	35.00 EA	\$5,906.88	\$206,740.80
425-1-922	INLETS, ADJACENT BARRIER, >10'	23.00 EA	\$9,281.70	\$213,479.10

**Drainage Component Total** \$1,069,543.49

**SIGNING COMPONENT**

**Pay Items**

Pay item	Description	Quantity Unit	Unit Price	Extended Amount
700-1-11	SINGLE POST SIGN, F&I GM, <12 SF	2.00 AS	\$380.22	\$760.44
700-1-12	SINGLE POST SIGN, F&I GM, 12-20 SF	18.00 AS	\$1,503.18	\$27,057.24
700-2-14	MULTI- POST SIGN, F&I GM, 31-50 SF	2.00 AS	\$5,637.01	\$11,274.02
700-2-15	MULTI- POST SIGN, F&I GM, 51-100 SF	5.00 AS	\$7,713.11	\$38,565.55

**X-Items**

Pay item	Description	Quantity Unit	Unit Price	Extended Amount
700-4-114	OH STATIC SIGN STR, F&I, C 41-50 FT	1.00 EA	\$94,981.18	\$94,981.18
700-4-127	OH STATIC SIGN STR, F&I, S 151-200 FT	1.00 EA	\$211,285.18	\$211,285.18

**Signing Component Total** \$383,923.61

**INTELLIGENT TRAFFIC SYSTEM (ITS) COMPONENT**

**Description of Work**

General ITS per LF of roadway.

**EX-Items**

Pay item	Description	Quantity Unit	Unit Price	Extended Amount
000-000	GENERAL ITS	6,126.00 LF	\$70.00	\$428,820.00
	<b>Comment:</b> General ITS per LF of roadway. Assume \$70/LF			

**Intelligent Traffic System (ITS) Component Total** \$428,820.00

**LIGHTING COMPONENT**

**Rural Lighting Subcomponent**

**Description** **Value**



Multiplier (Number of Poles)

49

**Pay Items**

Pay item	Description	Quantity	Unit	Unit Price	Extended Amount
630-2-11	CONDUIT, F& I, OPEN TRENCH	9,800.00	LF	\$9.76	\$95,648.00
635-2-11	PULL & SPLICE BOX, F&I, 13" x 24"	49.00	EA	\$767.98	\$37,631.02
715-1-13	LIGHTING CONDUCTORS, F&I, INSUL, NO.4-2	29,400.00	LF	\$2.62	\$77,028.00
715-4-14	LIGHT POLE COMPLETE, F&I-STD, 45'	49.00	EA	\$7,063.23	\$346,098.27
715-500-1	POLE CABLE DIST SYS, CONVENTIONAL	49.00	EA	\$621.64	\$30,460.36
<b>Subcomponent Total</b>					<b>\$586,865.65</b>
<b>Lighting Component Total</b>					<b>\$586,865.65</b>

**LANDSCAPING COMPONENT****User Input Data**

Description	Value
Cost %	2.00
Component Detail	N

**Landscaping Component Total** **\$150,664.94**

**BRIDGES COMPONENT****Bridge 538-3**

Description	Value
Estimate Type	SF Estimate
Primary Estimate	YES
Length (LF)	2,218.00
Width (LF)	63.00
Type	High Level
Cost Factor	2.04
Structure No.	
Removal of Existing Structures area	0.00
Default Cost per SF	\$135.00
Factored Cost per SF	\$275.40
<b>Final Cost per SF</b>	<b>\$276.19</b>
<b>Basic Bridge Cost</b>	<b>\$38,482,743.60</b>

Description SOUTHBOUND 3-LANE BRIDGE: SR 538 TO SOUTH OF OLD LAKE WILSON

**Bridge Pay Items**

Pay item	Description	Quantity	Unit	Unit Price	Extended Amount
400-2-10	CONC CLASS II, APPROACH SLABS	140.00	CY	\$588.22	\$82,350.80
415-1-9	REINF STEEL- APPROACH SLABS	24,500.00	LB	\$1.14	\$27,930.00
<b>Bridge 538-3 Total</b>					<b>\$38,593,024.40</b>

**Bridge 538-5**

Description	Value
Estimate Type	SF Estimate
Primary Estimate	YES
Length (LF)	3,100.00

Width (LF)	63.00
Type	High Level
Cost Factor	2.04
Structure No.	
Removal of Existing Structures area	0.00
Default Cost per SF	\$135.00
Factored Cost per SF	\$275.40
<b>Final Cost per SF</b>	<b>\$275.96</b>
<b>Basic Bridge Cost</b>	<b>\$53,785,620.00</b>

NORTHBOUND 3-LANE BRIDGE: SR 538 TO SOUTH OF  
OLD LAKE WILSON

**Bridge Pay Items**

Pay item	Description	Quantity	Unit	Unit Price	Extended Amount
400-2-10	CONC CLASS II, APPROACH SLABS	140.00	CY	\$588.22	\$82,350.80
415-1-9	REINF STEEL- APPROACH SLABS	24,500.00	LB	\$1.14	\$27,930.00
<b>Bridge 538-5 Total</b>					<b>\$53,895,900.80</b>

**Bridge 538-4A**

<b>Description</b>	<b>Value</b>
Estimate Type	SF Estimate
Primary Estimate	YES
Length (LF)	700.00
Width (LF)	75.00
Type	Low Level
Cost Factor	1.33
Structure No.	
Removal of Existing Structures area	0.00
Default Cost per SF	\$135.00
Factored Cost per SF	\$179.55
<b>Final Cost per SF</b>	<b>\$182.05</b>
<b>Basic Bridge Cost</b>	<b>\$9,426,375.00</b>

SOUTHBOUND 4-LANE BRIDGE: SR 538 TO SOUTH OF  
OLD LAKE WILSON

**Bridge Pay Items**

Pay item	Description	Quantity	Unit	Unit Price	Extended Amount
400-2-10	CONC CLASS II, APPROACH SLABS	166.67	CY	\$588.22	\$98,038.63
415-1-9	REINF STEEL- APPROACH SLABS	29,167.25	LB	\$1.14	\$33,250.66
<b>Bridge 538-4A Total</b>					<b>\$9,557,664.30</b>

**Bridges Component Total** \$102,046,589.50

**RETAINING WALLS COMPONENT**

**Retaining Wall 1**

<b>Description</b>	<b>Value</b>
Length	4,392.00
Begin height	17.50
End Height	17.50
Multiplier	2

**Pay Items**

<b>Pay item</b>	<b>Description</b>	<b>Quantity</b>	<b>Unit</b>	<b>Unit Price</b>	<b>Extended Amount</b>
548-12	RET WALL SYSTEM, PERM, EX BARRIER	153,720.00	SF	\$36.17	\$5,560,052.40
<b>Retaining Walls Component Total</b>					\$5,560,052.40

---

**Sequence 3 Total** \$121,530,056.98

---

**Sequence:** 4 NDR - New Construction, Divided, Rural

**Net Length:** 0.240 MI  
1,267 LF

**Description:** SR 429 Mainline 4-Lane Divided, Standard Inside Shoulders, Retaining Wall, Outside Shoulders.  
2 Lane SB/2 Lane NB. Bridges 538-6, 538-7.

---

### EARTHWORK COMPONENT

#### User Input Data

Description	Value
Standard Clearing and Grubbing Limits L/R	161.00 / 161.00
Incidental Clearing and Grubbing Area	0.00
Alignment Number	1
Distance	0.240
Top of Structural Course For Begin Section	105.00
Top of Structural Course For End Section	105.00
Horizontal Elevation For Begin Section	100.00
Horizontal Elevation For End Section	100.00
Front Slope L/R	6 to 1 / 6 to 1
Median Slope L/R	6 to 1 / 6 to 1
Median Shoulder Cross Slope L/R	5.00 % / 5.00 %
Outside Shoulder Cross Slope L/R	6.00 % / 6.00 %
Roadway Cross Slope L/R	2.00 % / 2.00 %

#### Pay Items

Pay item	Description	Quantity	Unit	Unit Price	Extended Amount
110-1-1	CLEARING & GRUBBING	9.37	AC	\$21,000.00	\$196,770.00
120-6	EMBANKMENT	28,993.54	CY	\$20.88	\$605,385.12
<b>Earthwork Component Total</b>					<b>\$802,155.12</b>

---

### ROADWAY COMPONENT

#### User Input Data

Description	Value
Number of Lanes	5
Roadway Pavement Width L/R	24.00 / 24.00
Structural Spread Rate	440
Friction Course Spread Rate	80

#### Pay Items

Pay item	Description	Quantity	Unit	Unit Price	Extended Amount
160-4	TYPE B STABILIZATION	13,516.80	SY	\$11.66	\$157,605.89
285-712	OPTIONAL BASE,BASE GROUP 12	6,944.26	SY	\$73.16	\$508,042.06
334-1-13	SUPERPAVE ASPHALTIC CONC, TRAFFIC C	1,486.85	TN	\$126.72	\$188,413.63
337-7-25	ASPH CONC FC,INC BIT,FC- 5,PG76-22	270.34	TN	\$159.94	\$43,238.18

#### Pavement Marking Subcomponent

Description	Value
Include Thermo/Tape/Other	Y
Pavement Type	Asphalt
Solid Stripe No. of Paint Applications	1
Solid Stripe No. of Stripes	4
Skip Stripe No. of Paint Applications	1
Skip Stripe No. of Stripes	3

**Pay Items**

Pay item	Description	Quantity Unit	Unit Price	Extended Amount
706-1-1	RAISED PAVMT MARK, TYPE B W/O FINAL SURF	130.00 EA	\$3.58	\$465.40
710-11-101	PAINTED PAVT MARK,STD,WHITE,SOLID,6"	0.96 GM	\$1,080.33	\$1,037.12
710-11-131	PAINTED PAVT MARK,STD,WHITE,SKIP, 6"	0.72 GM	\$460.80	\$331.78
711-15-101	THERMOPLASTIC, STD-OP, WHITE, SOLID, 6"	0.96 GM	\$4,966.76	\$4,768.09
711-15-131	THERMOPLASTIC, STD-OP, WHITE, SKIP, 6"	0.72 GM	\$1,845.33	\$1,328.64
711-15-201	THERMOPLASTIC, STD- OP,YELLOW, SOLID, 6"	0.96 GM	\$4,988.35	\$4,788.82

**Peripherals Subcomponent**

Description	Value
Off Road Bike Path(s)	0
Off Road Bike Path Width L/R	0.00 / 0.00
Bike Path Structural Spread Rate	0
Noise Barrier Wall Length	0.00
Noise Barrier Wall Begin Height	0.00
Noise Barrier Wall End Height	0.00

**Pay Items**

Pay item	Description	Quantity Unit	Unit Price	Extended Amount
521-72-40	SHLDR CONC BARRIER,38" OR 44" HEIGHT	1,450.00 LF	\$306.25	\$444,062.50
550-10-120	FENCING, TYPE A, 5.1-6.0, STANDARD	9,010.00 LF	\$9.26	\$83,432.60

**Roadway Component Total**

\$1,437,514.71

**SHOULDER COMPONENT****User Input Data**

Description	Value
Total Outside Shoulder Width L/R	12.00 / 12.00
Total Outside Shoulder Perf. Turf Width L/R	0.00 / 0.00
Paved Outside Shoulder Width L/R	12.00 / 12.00
Structural Spread Rate	220
Friction Course Spread Rate	80
Total Width (T) / 8" Overlap (O)	0
Rumble Strips 1/2No. of Sides	2

**Pay Items**

Pay item	Description	Quantity Unit	Unit Price	Extended Amount
285-705	OPTIONAL BASE,BASE GROUP 05	3,472.13 SY	\$40.53	\$140,725.43
334-1-13	SUPERPAVE ASPHALTIC CONC, TRAFFIC C	371.71 TN	\$126.72	\$47,103.09
337-7-25	ASPH CONC FC,INC BIT,FC- 5,PG76-22	7.43 TN	\$159.94	\$1,188.35
546-72-1	GROUND-IN RUMBLE STRIPS, 16"	0.48 GM	\$881.71	\$423.22

**X-Items**

Pay item	Description	Quantity Unit	Unit Price	Extended Amount
521-8-7	CONC BARRIER, W/JUNCT SL, 36 SS	800.00 LF	\$303.07	\$242,456.00



**Erosion Control****Pay Items**

Pay item	Description	Quantity	Unit	Unit Price	Extended Amount
104-10-3	SEDIMENT BARRIER	3,294.72	LF	\$1.20	\$3,953.66
104-11	FLOATING TURBIDITY BARRIER	60.00	LF	\$9.49	\$569.40
104-12	STAKED TURBIDITY BARRIER- NYL REINF PVC	60.00	LF	\$4.44	\$266.40
104-15	SOIL TRACKING PREVENTION DEVICE	1.00	EA	\$2,988.11	\$2,988.11
104-18	INLET PROTECTION SYSTEM	2.00	EA	\$88.37	\$176.74
107-1	LITTER REMOVAL	5.82	AC	\$20.76	\$120.82
107-2	MOWING	5.82	AC	\$46.89	\$272.90
<b>Shoulder Component Total</b>					<b>\$440,244.12</b>

**MEDIAN COMPONENT****User Input Data**

Description	Value
Total Median Width	74.00
Performance Turf Width	66.00
Total Median Shoulder Width L/R	12.00 / 12.00
Paved Median Shoulder Width L/R	10.00 / 10.00
Structural Spread Rate	220
Friction Course Spread Rate	80
Total Width (T) / 8" Overlap (O)	O
Rumble Strips $\bar{i}_i$ 1/2 No. of Sides	2

**Pay Items**

Pay item	Description	Quantity	Unit	Unit Price	Extended Amount
285-705	OPTIONAL BASE,BASE GROUP 05	2,908.93	SY	\$40.53	\$117,898.93
334-1-13	SUPERPAVE ASPHALTIC CONC, TRAFFIC C	309.76	TN	\$126.72	\$39,252.79
337-7-25	ASPH CONC FC,INC BIT,FC- 5,PG76-22	7.43	TN	\$159.94	\$1,188.35
570-1-2	PERFORMANCE TURF, SOD	9,292.80	SY	\$4.09	\$38,007.55
<b>Median Component Total</b>					<b>\$196,347.62</b>

**DRAINAGE COMPONENT****Pay Items**

Pay item	Description	Quantity	Unit	Unit Price	Extended Amount
425-1-551	INLETS, DT BOT, TYPE E, <10'	2.00	EA	\$13,191.95	\$26,383.90
430-174-124	PIPE CULV, OPT MATL, ROUND,24"SD	192.00	LF	\$126.21	\$24,232.32
430-175-124	PIPE CULV, OPT MATL, ROUND, 24"S/CD	88.00	LF	\$128.82	\$11,336.16
430-175-136	PIPE CULV, OPT MATL, ROUND, 36"S/CD	72.00	LF	\$342.26	\$24,642.72
430-984-129	MITERED END SECT, OPTIONAL RD, 24" SD	10.00	EA	\$2,253.96	\$22,539.60
524-1-1	CONCRETE DITCH PAVT, NR, 3"	480.00	SY	\$218.44	\$104,851.20
570-1-1	PERFORMANCE TURF	168.96	SY	\$3.19	\$538.98
<b>Drainage Component Total</b>					<b>\$214,524.88</b>

---

**SIGNING COMPONENT**

**Pay Items**

<b>Pay item</b>	<b>Description</b>	<b>Quantity</b>	<b>Unit</b>	<b>Unit Price</b>	<b>Extended Amount</b>
700-1-11	SINGLE POST SIGN, F&I GM, <12 SF	1.00	AS	\$380.22	\$380.22
700-1-12	SINGLE POST SIGN, F&I GM, 12-20 SF	6.00	AS	\$1,503.18	\$9,019.08
700-2-14	MULTI- POST SIGN, F&I GM, 31-50 SF	1.00	AS	\$5,637.01	\$5,637.01
700-2-15	MULTI- POST SIGN, F&I GM, 51-100 SF	2.00	AS	\$7,713.11	\$15,426.22
<b>Signing Component Total</b>					<b>\$30,462.53</b>

---

**INTELLIGENT TRAFFIC SYSTEM (ITS) COMPONENT**

**Description of Work**

General ITS per LF of roadway.

**EX-Items**

<b>Pay item</b>	<b>Description</b>	<b>Quantity</b>	<b>Unit</b>	<b>Unit Price</b>	<b>Extended Amount</b>
000-000	GENERAL ITS <b>Comment:</b> General ITS per LF of roadway. Assume \$70/LF	7,534.00	LF	\$70.00	\$527,380.00
<b>Intelligent Traffic System (ITS) Component Total</b>					<b>\$527,380.00</b>

---

**LIGHTING COMPONENT**

**Rural Lighting Subcomponent**

**Description**

Multiplier (Number of Poles)

**Value**

48

**Pay Items**

<b>Pay item</b>	<b>Description</b>	<b>Quantity</b>	<b>Unit</b>	<b>Unit Price</b>	<b>Extended Amount</b>
630-2-11	CONDUIT, F& I, OPEN TRENCH	9,600.00	LF	\$9.76	\$93,696.00
635-2-11	PULL & SPLICE BOX, F&I, 13" x 24"	48.00	EA	\$767.98	\$36,863.04
715-1-13	LIGHTING CONDUCTORS, F&I, INSUL, NO.4-2	28,800.00	LF	\$2.62	\$75,456.00
715-4-14	LIGHT POLE COMPLETE, F&I-STD, 45'	48.00	EA	\$7,063.23	\$339,035.04
715-500-1	POLE CABLE DIST SYS, CONVENTIONAL	48.00	EA	\$621.64	\$29,838.72
<b>Subcomponent Total</b>					<b>\$574,888.80</b>
<b>Lighting Component Total</b>					<b>\$574,888.80</b>

---

**LANDSCAPING COMPONENT**

**User Input Data**

**Description**

Cost %

**Value**

2.00

Component Detail

N

**Landscaping Component Total**

**\$45,772.63**

**BRIDGES COMPONENT**

**Bridge 538-6**

<b>Description</b>	<b>Value</b>
Estimate Type	SF Estimate
Primary Estimate	YES
Length (LF)	3,615.00
Width (LF)	49.00
Type	High Level
Cost Factor	2.04
Structure No.	
Removal of Existing Structures area	0.00
Default Cost per SF	\$135.00
Factored Cost per SF	\$275.40
<b>Final Cost per SF</b>	<b>\$275.88</b>
<b>Basic Bridge Cost</b>	<b>\$48,782,979.00</b>

Description SOUTHBOUND 2-LANE BRIDGE: SR 538 FROM SOUTH OF OLD LAKE WILSON OVER OLD LAKE WILSON AND I-4

**Bridge Pay Items**

Pay item	Description	Quantity	Unit	Unit Price	Extended Amount
400-2-10	CONC CLASS II, APPROACH SLABS	108.89	CY	\$588.22	\$64,051.28
415-1-9	REINF STEEL- APPROACH SLABS	19,055.75	LB	\$1.14	\$21,723.56
<b>Bridge 538-6 Total</b>					<b>\$48,868,753.84</b>

**Bridge 538-7**

<b>Description</b>	<b>Value</b>
Estimate Type	SF Estimate
Primary Estimate	YES
Length (LF)	3,029.00
Width (LF)	47.00
Type	High Level
Cost Factor	2.04
Structure No.	
Removal of Existing Structures area	0.00
Default Cost per SF	\$135.00
Factored Cost per SF	\$275.40
<b>Final Cost per SF</b>	<b>\$275.98</b>
<b>Basic Bridge Cost</b>	<b>\$39,206,770.20</b>

Description NORTHBOUND 2-LANE BRIDGE: SR 538 FROM SOUTH OF OLD LAKE WILSON OVER OLD LAKE WILSON AND I-4

**Bridge Pay Items**

Pay item	Description	Quantity	Unit	Unit Price	Extended Amount
400-2-10	CONC CLASS II, APPROACH SLABS	104.44	CY	\$588.22	\$61,433.70
415-1-9	REINF STEEL- APPROACH SLABS	18,277.00	LB	\$1.14	\$20,835.78
<b>Bridge 538-7 Total</b>					<b>\$39,289,039.68</b>

**Bridges Component Total** **\$88,157,793.52**

**RETAINING WALLS COMPONENT**

**Retaining Wall 1**

<b>Description</b>	<b>Value</b>
Length	930.00
Begin height	17.50
End Height	17.50
Multiplier	2

**Pay Items**

<b>Pay item</b>	<b>Description</b>	<b>Quantity</b>	<b>Unit</b>	<b>Unit Price</b>	<b>Extended Amount</b>
548-12	RET WALL SYSTEM, PERM, EX BARRIER	32,550.00	SF	\$36.17	\$1,177,333.50
<b>Retaining Walls Component Total</b>					<b>\$1,177,333.50</b>

---

**Sequence 4 Total** **\$93,604,417.43**

---

Sequence: 5 NDR - New Construction, Divided, Rural

Net Length: 0.432 MI  
2,279 LF

Description: SR 429 Mainline 4-Lane Divided, Standard Inside Shoulders, Rural, Outside Shoulders.

**EARTHWORK COMPONENT**

**User Input Data**

Description	Value
Standard Clearing and Grubbing Limits L/R	161.00 / 161.00
Incidental Clearing and Grubbing Area	0.00
Alignment Number	1
Distance	0.431
Top of Structural Course For Begin Section	105.00
Top of Structural Course For End Section	105.00
Horizontal Elevation For Begin Section	100.00
Horizontal Elevation For End Section	100.00
Front Slope L/R	6 to 1 / 6 to 1
Median Slope L/R	6 to 1 / 6 to 1
Median Shoulder Cross Slope L/R	5.00 % / 5.00 %
Outside Shoulder Cross Slope L/R	6.00 % / 6.00 %
Roadway Cross Slope L/R	2.00 % / 2.00 %

**Pay Items**

Pay item	Description	Quantity	Unit	Unit Price	Extended Amount
110-1-1	CLEARING & GRUBBING	16.86	AC	\$21,000.00	\$354,060.00
120-6	EMBANKMENT	51,406.77	CY	\$20.88	\$1,073,373.36
<b>Earthwork Component Total</b>					<b>\$1,427,433.36</b>

**ROADWAY COMPONENT**

**User Input Data**

Description	Value
Number of Lanes	4
Roadway Pavement Width L/R	24.00 / 24.00
Structural Spread Rate	440
Friction Course Spread Rate	80

**Pay Items**

Pay item	Description	Quantity	Unit	Unit Price	Extended Amount
160-4	TYPE B STABILIZATION	23,294.89	SY	\$11.66	\$271,618.42
285-712	OPTIONAL BASE,BASE GROUP 12	12,488.09	SY	\$73.16	\$913,628.66
334-1-13	SUPERPAVE ASPHALTIC CONC, TRAFFIC C	2,673.85	TN	\$126.72	\$338,830.27
337-7-25	ASPH CONC FC,INC BIT,FC- 5,PG76-22	486.15	TN	\$159.94	\$77,754.83

**Pavement Marking Subcomponent**

Description	Value
Include Thermo/Tape/Other	Y
Pavement Type	Asphalt
Solid Stripe No. of Paint Applications	1
Solid Stripe No. of Stripes	4
Skip Stripe No. of Paint Applications	1
Skip Stripe No. of Stripes	2

**Pay Items**



Pay item	Description	Quantity Unit	Unit Price	Extended Amount
706-1-1	RAISED PAVMT MARK, TYPE B W/O FINAL SURF	175.00 EA	\$3.58	\$626.50
710-11-101	PAINTED PAVT MARK,STD,WHITE,SOLID,6"	1.73 GM	\$1,080.33	\$1,868.97
710-11-131	PAINTED PAVT MARK,STD,WHITE,SKIP, 6"	0.86 GM	\$460.80	\$396.29
711-15-101	THERMOPLASTIC, STD-OP, WHITE, SOLID, 6"	1.73 GM	\$4,966.76	\$8,592.49
711-15-131	THERMOPLASTIC, STD-OP, WHITE, SKIP, 6"	0.86 GM	\$1,845.33	\$1,586.98
711-15-201	THERMOPLASTIC, STD-OP,YELLOW, SOLID, 6"	1.73 GM	\$4,988.35	\$8,629.85

#### Peripherals Subcomponent

Description	Value
Off Road Bike Path(s)	0
Off Road Bike Path Width L/R	0.00 / 0.00
Bike Path Structural Spread Rate	0
Noise Barrier Wall Length	0.00
Noise Barrier Wall Begin Height	0.00
Noise Barrier Wall End Height	0.00

#### Pay Items

Pay item	Description	Quantity Unit	Unit Price	Extended Amount
521-72-40	SHLDR CONC BARRIER,38" OR 44" HEIGHT	4,800.00 LF	\$306.25	\$1,470,000.00
550-10-120	FENCING, TYPE A, 5.1-6.0, STANDARD	4,558.00 LF	\$9.26	\$42,207.08
<b>Roadway Component Total</b>				<b>\$3,135,740.34</b>

### SHOULDER COMPONENT

#### User Input Data

Description	Value
Total Outside Shoulder Width L/R	10.00 / 10.00
Total Outside Shoulder Perf. Turf Width L/R	0.00 / 0.00
Paved Outside Shoulder Width L/R	10.00 / 10.00
Structural Spread Rate	220
Friction Course Spread Rate	80
Total Width (T) / 8" Overlap (O)	0
Rumble Strips i <sub>l</sub> ½No. of Sides	2

#### Pay Items

Pay item	Description	Quantity Unit	Unit Price	Extended Amount
285-705	OPTIONAL BASE,BASE GROUP 05	5,231.22 SY	\$40.53	\$212,021.35
334-1-13	SUPERPAVE ASPHALTIC CONC, TRAFFIC C	557.05 TN	\$126.72	\$70,589.38
337-7-25	ASPH CONC FC,INC BIT,FC-5,PG76-22	13.37 TN	\$159.94	\$2,138.40
546-72-1	GROUND-IN RUMBLE STRIPS, 16"	0.86 GM	\$881.71	\$758.27

#### Erosion Control

#### Pay Items

Pay item	Description	Quantity Unit	Unit Price	Extended Amount
104-10-3	SEDIMENT BARRIER	5,925.00 LF	\$1.20	\$7,110.00
104-11	FLOATING TURBIDITY BARRIER	107.90 LF	\$9.49	\$1,023.97

104-12	STAKED TURBIDITY BARRIER- NYL REINF PVC	107.90 LF	\$4.44	\$479.08
104-15	SOIL TRACKING PREVENTION DEVICE	1.00 EA	\$2,988.11	\$2,988.11
104-18	INLET PROTECTION SYSTEM	3.00 EA	\$88.37	\$265.11
107-1	LITTER REMOVAL	10.46 AC	\$20.76	\$217.15
107-2	MOWING	10.46 AC	\$46.89	\$490.47

**Shoulder Component Total**

\$298,081.29

**MEDIAN COMPONENT**

**User Input Data**

Description	Value
Total Median Width	74.00
Performance Turf Width	54.00
Total Median Shoulder Width L/R	12.00 / 12.00
Paved Median Shoulder Width L/R	10.00 / 10.00
Structural Spread Rate	220
Friction Course Spread Rate	80
Total Width (T) / 8" Overlap (O)	O
Rumble Strips i; ½No. of Sides	2

**Pay Items**

Pay item	Description	Quantity Unit	Unit Price	Extended Amount
285-705	OPTIONAL BASE,BASE GROUP 05	5,231.22 SY	\$40.53	\$212,021.35
334-1-13	SUPERPAVE ASPHALTIC CONC, TRAFFIC C	557.05 TN	\$126.72	\$70,589.38
337-7-25	ASPH CONC FC,INC BIT,FC- 5,PG76-22	13.37 TN	\$159.94	\$2,138.40
546-72-1	GROUND-IN RUMBLE STRIPS, 16"	1.00 GM	\$881.71	\$881.71
570-1-2	PERFORMANCE TURF, SOD	13,673.09 SY	\$4.09	\$55,922.94

**Median Component Total**

\$341,553.78

**DRAINAGE COMPONENT**

**Pay Items**

Pay item	Description	Quantity Unit	Unit Price	Extended Amount
425-1-551	INLETS, DT BOT, TYPE E, <10'	3.00 EA	\$13,191.95	\$39,575.85
430-174-124	PIPE CULV, OPT MATL, ROUND,24"SD	352.00 LF	\$126.21	\$44,425.92
430-175-124	PIPE CULV, OPT MATL, ROUND, 24"S/CD	152.00 LF	\$128.82	\$19,580.64
430-175-136	PIPE CULV, OPT MATL, ROUND, 36"S/CD	128.00 LF	\$342.26	\$43,809.28
430-984-129	MITERED END SECT, OPTIONAL RD, 24" SD	18.00 EA	\$2,253.96	\$40,571.28
524-1-1	CONCRETE DITCH PAVT, NR, 3"	863.20 SY	\$218.44	\$188,557.41
570-1-1	PERFORMANCE TURF	303.85 SY	\$3.19	\$969.28

**X-Items**

Pay item	Description	Quantity Unit	Unit Price	Extended Amount
425-1-921	INLETS, ADJACENT BARRIER, <=10'	12.00 EA	\$5,906.88	\$70,882.56

**Drainage Component Total**

\$448,372.22

---

**SIGNING COMPONENT**

**Pay Items**

Pay item	Description	Quantity	Unit	Unit Price	Extended Amount
700-1-11	SINGLE POST SIGN, F&I GM, <12 SF	1.00	AS	\$380.22	\$380.22
700-1-12	SINGLE POST SIGN, F&I GM, 12-20 SF	11.00	AS	\$1,503.18	\$16,534.98
700-2-14	MULTI- POST SIGN, F&I GM, 31-50 SF	1.00	AS	\$5,637.01	\$5,637.01
700-2-15	MULTI- POST SIGN, F&I GM, 51-100 SF	3.00	AS	\$7,713.11	\$23,139.33

**X-Items**

Pay item	Description	Quantity	Unit	Unit Price	Extended Amount
700-4-114	OH STATIC SIGN STR, F&I, C 41-50 FT	1.00	EA	\$94,981.18	\$94,981.18
700-4-127	OH STATIC SIGN STR, F&I, S 151-200 FT	1.00	EA	\$211,285.18	\$211,285.18

**Signing Component Total** \$351,957.90

---

**INTELLIGENT TRAFFIC SYSTEM (ITS) COMPONENT**

**Description of Work**

General ITS per LF of roadway.

**EX-Items**

Pay item	Description	Quantity	Unit	Unit Price	Extended Amount
000-000	GENERAL ITS	2,279.00	LF	\$70.00	\$159,530.00

**Comment:** General ITS per LF of roadway.

**Intelligent Traffic System (ITS) Component Total** \$159,530.00

---

**LIGHTING COMPONENT**

**Rural Lighting Subcomponent**

Description	Value				
Multiplier (Number of Poles)	24				
Pay item	Description	Quantity	Unit	Unit Price	Extended Amount
630-2-11	CONDUIT, F& I, OPEN TRENCH	4,800.00	LF	\$9.76	\$46,848.00
635-2-11	PULL & SPLICE BOX, F&I, 13" x 24"	24.00	EA	\$767.98	\$18,431.52
715-1-13	LIGHTING CONDUCTORS, F&I, INSUL, NO.4-2	14,400.00	LF	\$2.62	\$37,728.00
715-4-14	LIGHT POLE COMPLETE, F&I-STD, 45'	24.00	EA	\$7,063.23	\$169,517.52
715-500-1	POLE CABLE DIST SYS, CONVENTIONAL	24.00	EA	\$621.64	\$14,919.36
<b>Subcomponent Total</b>					<b>\$287,444.40</b>
<b>Lighting Component Total</b>					<b>\$287,444.40</b>

---

**LANDSCAPING COMPONENT**

**User Input Data**

**Description**

**Value**

Cost %

2.00

Component Detail

N

---

**Landscaping Component Total**

\$84,474.95

---

**Sequence 5 Total**

\$6,534,588.24

---

Sequence: 6 NDR - New Construction, Divided, Rural

Net Length: 0.582 MI  
3,074 LF

Description: SR 429 Mainline 8-Lane Divided, Standard Shoulders. 4-Lanes SB/5-Lanes NB

**EARTHWORK COMPONENT**

**User Input Data**

Description	Value
Standard Clearing and Grubbing Limits L/R	185.00 / 185.00
Incidental Clearing and Grubbing Area	0.00
Alignment Number	1
Distance	0.580
Top of Structural Course For Begin Section	105.00
Top of Structural Course For End Section	105.00
Horizontal Elevation For Begin Section	100.00
Horizontal Elevation For End Section	100.00
Front Slope L/R	6 to 1 / 6 to 1
Median Slope L/R	6 to 1 / 6 to 1
Median Shoulder Cross Slope L/R	5.00 % / 5.00 %
Outside Shoulder Cross Slope L/R	6.00 % / 6.00 %
Roadway Cross Slope L/R	2.00 % / 2.00 %

**Pay Items**

Pay item	Description	Quantity Unit	Unit Price	Extended Amount
110-1-1	CLEARING & GRUBBING	26.10 AC	\$21,000.00	\$548,100.00
120-6	EMBANKMENT	78,408.78 CY	\$20.88	\$1,637,175.33
<b>Earthwork Component Total</b>				<b>\$2,185,275.33</b>

**ROADWAY COMPONENT**

**User Input Data**

Description	Value
Number of Lanes	6
Roadway Pavement Width L/R	48.00 / 48.00
Structural Spread Rate	440
Friction Course Spread Rate	80

**Pay Items**

Pay item	Description	Quantity Unit	Unit Price	Extended Amount
160-4	TYPE B STABILIZATION	49,184.26 SY	\$11.66	\$573,488.47
285-712	OPTIONAL BASE,BASE GROUP 12	33,240.36 SY	\$73.16	\$2,431,864.74
334-1-13	SUPERPAVE ASPHALTIC CONC, TRAFFIC C	7,213.69 TN	\$126.72	\$914,118.80
337-7-25	ASPH CONC FC,INC BIT,FC- 5,PG76-22	1,311.58 TN	\$159.94	\$209,774.11

**Pavement Marking Subcomponent**

Description	Value
Include Thermo/Tape/Other	Y
Pavement Type	Asphalt
Solid Stripe No. of Paint Applications	1
Solid Stripe No. of Stripes	4
Skip Stripe No. of Paint Applications	1
Skip Stripe No. of Stripes	4

**Pay Items**



Pay item	Description	Quantity Unit	Unit Price	Extended Amount
706-1-1	RAISED PAVMT MARK, TYPE B W/O FINAL SURF	393.00 EA	\$3.58	\$1,406.94
710-11-101	PAINTED PAVT MARK,STD,WHITE,SOLID,6"	2.33 GM	\$1,080.33	\$2,517.17
710-11-131	PAINTED PAVT MARK,STD,WHITE,SKIP, 6"	2.33 GM	\$460.80	\$1,073.66
711-15-101	THERMOPLASTIC, STD-OP, WHITE, SOLID, 6"	2.33 GM	\$4,966.76	\$11,572.55
711-15-131	THERMOPLASTIC, STD-OP, WHITE, SKIP, 6"	2.33 GM	\$1,845.33	\$4,299.62
711-15-201	THERMOPLASTIC, STD- OP,YELLOW, SOLID, 6"	2.33 GM	\$4,988.35	\$11,622.86

#### Peripherals Subcomponent

Description	Value
Off Road Bike Path(s)	0
Off Road Bike Path Width L/R	0.00 / 0.00
Bike Path Structural Spread Rate	0
Noise Barrier Wall Length	0.00
Noise Barrier Wall Begin Height	0.00
Noise Barrier Wall End Height	0.00

#### Pay Items

Pay item	Description	Quantity Unit	Unit Price	Extended Amount
550-10-120	FENCING, TYPE A, 5.1-6.0, STANDARD	6,148.00 LF	\$9.26	\$56,930.48

#### Roadway Component Total

\$4,218,669.40

### SHOULDER COMPONENT

#### User Input Data

Description	Value
Total Outside Shoulder Width L/R	12.00 / 12.00
Total Outside Shoulder Perf. Turf Width L/R	2.00 / 2.00
Paved Outside Shoulder Width L/R	10.00 / 10.00
Structural Spread Rate	220
Friction Course Spread Rate	80
Total Width (T) / 8" Overlap (O)	0
Rumble Strips i <sub>c</sub> ½No. of Sides	2

#### Pay Items

Pay item	Description	Quantity Unit	Unit Price	Extended Amount
285-705	OPTIONAL BASE,BASE GROUP 05	7,056.57 SY	\$40.53	\$286,002.78
334-1-13	SUPERPAVE ASPHALTIC CONC, TRAFFIC C	751.43 TN	\$126.72	\$95,221.21
337-7-25	ASPH CONC FC,INC BIT,FC- 5,PG76-22	18.03 TN	\$159.94	\$2,883.72
546-72-1	GROUND-IN RUMBLE STRIPS, 16"	1.16 GM	\$881.71	\$1,022.78
570-1-1	PERFORMANCE TURF	1,366.23 SY	\$3.19	\$4,358.27

#### Erosion Control

#### Pay Items

Pay item	Description	Quantity Unit	Unit Price	Extended Amount
104-10-3	SEDIMENT BARRIER	7,992.44 LF	\$1.20	\$9,590.93
104-11	FLOATING TURBIDITY BARRIER	145.55 LF	\$9.49	\$1,381.27

104-12	STAKED TURBIDITY BARRIER- NYL REINF PVC	145.55 LF	\$4.44	\$646.24
104-15	SOIL TRACKING PREVENTION DEVICE	1.00 EA	\$2,988.11	\$2,988.11
104-18	INLET PROTECTION SYSTEM	4.00 EA	\$88.37	\$353.48
107-1	LITTER REMOVAL	14.11 AC	\$20.76	\$292.92
107-2	MOWING	14.11 AC	\$46.89	\$661.62
<b>Shoulder Component Total</b>				\$405,403.33

#### MEDIAN COMPONENT

##### User Input Data

Description	Value
Total Median Width	62.00
Performance Turf Width	42.00
Total Median Shoulder Width L/R	12.00 / 12.00
Paved Median Shoulder Width L/R	12.00 / 12.00
Structural Spread Rate	220
Friction Course Spread Rate	80
Total Width (T) / 8" Overlap (O)	O
Rumble Strips $\frac{1}{2}$ No. of Sides	2

##### Pay Items

Pay item	Description	Quantity Unit	Unit Price	Extended Amount
285-705	OPTIONAL BASE,BASE GROUP 05	8,422.80 SY	\$40.53	\$341,376.08
334-1-13	SUPERPAVE ASPHALTIC CONC, TRAFFIC C	901.71 TN	\$126.72	\$114,264.69
337-7-25	ASPH CONC FC,INC BIT,FC- 5,PG76-22	18.03 TN	\$159.94	\$2,883.72
521-1-11	MEDIAN CONC BARRIER, 38" HEIGHT	3,100.00 LF	\$316.17	\$980,127.00
546-72-1	GROUND-IN RUMBLE STRIPS, 16"	1.00 GM	\$881.71	\$881.71
570-1-2	PERFORMANCE TURF, SOD	14,345.41 SY	\$4.09	\$58,672.73
<b>Median Component Total</b>				\$1,498,205.93

#### DRAINAGE COMPONENT

##### Pay Items

Pay item	Description	Quantity Unit	Unit Price	Extended Amount
425-1-551	INLETS, DT BOT, TYPE E, <10'	4.00 EA	\$13,191.95	\$52,767.80
430-174-124	PIPE CULV, OPT MATL, ROUND,24"SD	472.00 LF	\$126.21	\$59,571.12
430-175-124	PIPE CULV, OPT MATL, ROUND, 24"S/CD	208.00 LF	\$128.82	\$26,794.56
430-175-136	PIPE CULV, OPT MATL, ROUND, 36"S/CD	176.00 LF	\$342.26	\$60,237.76
430-984-129	MITERED END SECT, OPTIONAL RD, 24" SD	24.00 EA	\$2,253.96	\$54,095.04
524-1-1	CONCRETE DITCH PAVT, NR, 3"	1,164.40 SY	\$218.44	\$254,351.54
570-1-1	PERFORMANCE TURF	409.87 SY	\$3.19	\$1,307.49
<b>Drainage Component Total</b>				\$509,125.31

#### SIGNING COMPONENT

<b>Pay Items</b>					
<b>Pay item</b>	<b>Description</b>	<b>Quantity</b>	<b>Unit</b>	<b>Unit Price</b>	<b>Extended Amount</b>
700-1-11	SINGLE POST SIGN, F&I GM, <12 SF	2.00	AS	\$380.22	\$760.44
700-1-12	SINGLE POST SIGN, F&I GM, 12-20 SF	14.00	AS	\$1,503.18	\$21,044.52
700-2-14	MULTI- POST SIGN, F&I GM, 31-50 SF	2.00	AS	\$5,637.01	\$11,274.02
700-2-15	MULTI- POST SIGN, F&I GM, 51-100 SF	4.00	AS	\$7,713.11	\$30,852.44

<b>X-Items</b>					
<b>Pay item</b>	<b>Description</b>	<b>Quantity</b>	<b>Unit</b>	<b>Unit Price</b>	<b>Extended Amount</b>
700-4-114	OH STATIC SIGN STR, F&I, C 41-50 FT	2.00	EA	\$94,981.18	\$189,962.36
700-4-127	OH STATIC SIGN STR, F&I, S 151-200 FT	1.00	EA	\$211,285.18	\$211,285.18
<b>Signing Component Total</b>					<b>\$465,178.96</b>

### INTELLIGENT TRAFFIC SYSTEM (ITS) COMPONENT

**Description of Work**

General ITS per LF of roadway.

<b>EX-Items</b>					
<b>Pay item</b>	<b>Description</b>	<b>Quantity</b>	<b>Unit</b>	<b>Unit Price</b>	<b>Extended Amount</b>
000-000	GENERAL ITS	3,074.00	LF	\$70.00	\$215,180.00
<b>Comment:</b> General ITS per LF of roadway.					
<b>Intelligent Traffic System (ITS) Component Total</b>					<b>\$215,180.00</b>

### LIGHTING COMPONENT

**Rural Lighting Subcomponent**

<b>Description</b>	<b>Value</b>
Multiplier (Number of Poles)	33

<b>Pay Items</b>					
<b>Pay item</b>	<b>Description</b>	<b>Quantity</b>	<b>Unit</b>	<b>Unit Price</b>	<b>Extended Amount</b>
630-2-11	CONDUIT, F& I, OPEN TRENCH	6,600.00	LF	\$9.76	\$64,416.00
635-2-11	PULL & SPLICE BOX, F&I, 13" x 24"	33.00	EA	\$767.98	\$25,343.34
715-1-13	LIGHTING CONDUCTORS, F&I, INSUL, NO.4-2	19,800.00	LF	\$2.62	\$51,876.00
715-4-14	LIGHT POLE COMPLETE, F&I-STD, 45'	33.00	EA	\$7,063.23	\$233,086.59
715-500-1	POLE CABLE DIST SYS, CONVENTIONAL	33.00	EA	\$621.64	\$20,514.12
<b>Subcomponent Total</b>					<b>\$395,236.05</b>
<b>Lighting Component Total</b>					<b>\$395,236.05</b>

### LANDSCAPING COMPONENT

**User Input Data**

<b>Description</b>	<b>Value</b>
Cost %	2.00

Component Detail

N

**Landscaping Component Total**

\$132,628.08

---

**Sequence 6 Total**

\$10,024,902.39

---

Sequence: 7 NDR - New Construction, Divided, Rural

Net Length: 0.113 MI  
597 LF

Description: SR 429 Mainline. 8-LANE DIVIDED, RURAL, RETAINING WALLS, RECONSTRUCTION. 4-Lane SB/4-Lane NB. BRIDGES 429-1 AND 429-2.

---

### EARTHWORK COMPONENT

#### User Input Data

Description	Value
Standard Clearing and Grubbing Limits L/R	173.00 / 173.00
Incidental Clearing and Grubbing Area	0.00
Alignment Number	1
Distance	0.113
Top of Structural Course For Begin Section	105.00
Top of Structural Course For End Section	131.00
Horizontal Elevation For Begin Section	100.00
Horizontal Elevation For End Section	100.00
Front Slope L/R	1 to 1 / 1 to 1
Median Slope L/R	1 to 1 / 1 to 1
Median Shoulder Cross Slope L/R	5.00 % / 5.00 %
Outside Shoulder Cross Slope L/R	6.00 % / 6.00 %
Roadway Cross Slope L/R	2.00 % / 2.00 %

#### Pay Items

Pay item	Description	Quantity	Unit	Unit Price	Extended Amount
110-1-1	CLEARING & GRUBBING	4.74	AC	\$21,000.00	\$99,540.00
120-6	EMBANKMENT	74,360.35	CY	\$20.88	\$1,552,644.11
<b>Earthwork Component Total</b>					<b>\$1,652,184.11</b>

---

### ROADWAY COMPONENT

#### User Input Data

Description	Value
Number of Lanes	6
Roadway Pavement Width L/R	48.00 / 48.00
Structural Spread Rate	440
Friction Course Spread Rate	80

#### Pay Items

Pay item	Description	Quantity	Unit	Unit Price	Extended Amount
160-4	TYPE B STABILIZATION	9,023.87	SY	\$11.66	\$105,218.32
285-712	OPTIONAL BASE,BASE GROUP 12	6,457.38	SY	\$73.16	\$472,421.92
334-1-13	SUPERPAVE ASPHALTIC CONC, TRAFFIC C	1,401.35	TN	\$126.72	\$177,579.07
337-7-25	ASPH CONC FC,INC BIT,FC- 5,PG76-22	254.79	TN	\$159.94	\$40,751.11

#### Pavement Marking Subcomponent

Description	Value
Include Thermo/Tape/Other	Y
Pavement Type	Asphalt
Solid Stripe No. of Paint Applications	1
Solid Stripe No. of Stripes	4
Skip Stripe No. of Paint Applications	1
Skip Stripe No. of Stripes	4



**Pay Items**

Pay item	Description	Quantity	Unit	Unit Price	Extended Amount
706-1-1	RAISED PAVMT MARK, TYPE B W/O FINAL SURF	76.00	EA	\$3.58	\$272.08
710-11-101	PAINTED PAVT MARK,STD,WHITE,SOLID,6"	0.45	GM	\$1,080.33	\$486.15
710-11-131	PAINTED PAVT MARK,STD,WHITE,SKIP, 6"	0.45	GM	\$460.80	\$207.36
711-15-101	THERMOPLASTIC, STD-OP, WHITE, SOLID, 6"	0.45	GM	\$4,966.76	\$2,235.04
711-15-131	THERMOPLASTIC, STD-OP, WHITE, SKIP, 6"	0.45	GM	\$1,845.33	\$830.40
711-15-201	THERMOPLASTIC, STD- OP,YELLOW, SOLID, 6"	0.45	GM	\$4,988.35	\$2,244.76

**Peripherals Subcomponent**

Description	Value
Off Road Bike Path(s)	0
Off Road Bike Path Width L/R	0.00 / 0.00
Bike Path Structural Spread Rate	0
Noise Barrier Wall Length	0.00
Noise Barrier Wall Begin Height	0.00
Noise Barrier Wall End Height	0.00

**Pay Items**

Pay item	Description	Quantity	Unit	Unit Price	Extended Amount
550-10-120	FENCING, TYPE A, 5.1-6.0, STANDARD	1,466.00	LF	\$9.26	\$13,575.16

**Roadway Component Total**

\$815,821.37

**SHOULDER COMPONENT****User Input Data**

Description	Value
Total Outside Shoulder Width L/R	10.00 / 10.00
Total Outside Shoulder Perf. Turf Width L/R	0.00 / 0.00
Paved Outside Shoulder Width L/R	10.00 / 10.00
Structural Spread Rate	220
Friction Course Spread Rate	80
Total Width (T) / 8" Overlap (O)	0
Rumble Strips 1/2 No. of Sides	2

**Pay Items**

Pay item	Description	Quantity	Unit	Unit Price	Extended Amount
285-705	OPTIONAL BASE,BASE GROUP 05	1,370.83	SY	\$40.53	\$55,559.74
334-1-13	SUPERPAVE ASPHALTIC CONC, TRAFFIC C	145.97	TN	\$126.72	\$18,497.32
337-7-25	ASPH CONC FC,INC BIT,FC- 5,PG76-22	3.50	TN	\$159.94	\$559.79
546-72-1	GROUND-IN RUMBLE STRIPS, 16"	0.23	GM	\$881.71	\$202.79

**X-Items**

Pay item	Description	Quantity	Unit	Unit Price	Extended Amount
521-8-7	CONC BARRIER, W/JUNCT SL, 36 SS	1,186.00	LF	\$303.07	\$359,441.02

**Erosion Control**

**Pay Items**

Pay item	Description	Quantity	Unit	Unit Price	Extended Amount
104-10-3	SEDIMENT BARRIER	1,552.64	LF	\$1.20	\$1,863.17
104-11	FLOATING TURBIDITY BARRIER	28.28	LF	\$9.49	\$268.38
104-12	STAKED TURBIDITY BARRIER- NYL REINF PVC	28.28	LF	\$4.44	\$125.56
104-15	SOIL TRACKING PREVENTION DEVICE	1.00	EA	\$2,988.11	\$2,988.11
104-18	INLET PROTECTION SYSTEM	2.00	EA	\$88.37	\$176.74
107-1	LITTER REMOVAL	2.74	AC	\$20.76	\$56.88
107-2	MOWING	2.74	AC	\$46.89	\$128.48
<b>Shoulder Component Total</b>					<b>\$439,867.98</b>

**MEDIAN COMPONENT****User Input Data**

Description	Value
Total Median Width	62.00
Performance Turf Width	42.00
Total Median Shoulder Width L/R	10.00 / 10.00
Paved Median Shoulder Width L/R	10.00 / 10.00
Structural Spread Rate	220
Friction Course Spread Rate	80
Total Width (T) / 8" Overlap (O)	T
Rumble Strips i; ½No. of Sides	2

**Pay Items**

Pay item	Description	Quantity	Unit	Unit Price	Extended Amount
285-705	OPTIONAL BASE,BASE GROUP 05	1,370.83	SY	\$40.53	\$55,559.74
334-1-13	SUPERPAVE ASPHALTIC CONC, TRAFFIC C	145.97	TN	\$126.72	\$18,497.32
337-7-25	ASPH CONC FC,INC BIT,FC- 5,PG76-22	53.08	TN	\$159.94	\$8,489.62
521-8-7	CONC BARRIER, W/JUNCT SL, 36 SS	1,196.00	LF	\$303.07	\$362,471.72
570-1-2	PERFORMANCE TURF, SOD	2,786.78	SY	\$4.09	\$11,397.93
<b>Median Component Total</b>					<b>\$456,416.33</b>

**DRAINAGE COMPONENT****Pay Items**

Pay item	Description	Quantity	Unit	Unit Price	Extended Amount
430-174-124	PIPE CULV, OPT MATL, ROUND,24"SD	96.00	LF	\$126.21	\$12,116.16
430-175-124	PIPE CULV, OPT MATL, ROUND, 24"S/CD	40.00	LF	\$128.82	\$5,152.80
430-175-136	PIPE CULV, OPT MATL, ROUND, 36"S/CD	40.00	LF	\$342.26	\$13,690.40
430-984-129	MITERED END SECT, OPTIONAL RD, 24" SD	4.00	EA	\$2,253.96	\$9,015.84
524-1-1	CONCRETE DITCH PAVT, NR, 3"	226.20	SY	\$218.44	\$49,411.13
570-1-1	PERFORMANCE TURF	79.62	SY	\$3.19	\$253.99

**X-Items**

Pay item	Description	Quantity	Unit	Unit Price	Extended Amount
----------	-------------	----------	------	------------	-----------------

425-1-921	INLETS, ADJACENT BARRIER, <=10'	4.00 EA	\$5,906.88	\$23,627.52
425-1-922	INLETS, ADJACENT BARRIER, >10'	4.00 EA	\$9,281.70	\$37,126.80
<b>Drainage Component Total</b>				<b>\$150,394.64</b>

**SIGNING COMPONENT**

**Pay Items**

Pay item	Description	Quantity Unit	Unit Price	Extended Amount
700-1-11	SINGLE POST SIGN, F&I GM, <12 SF	1.00 AS	\$380.22	\$380.22
700-1-12	SINGLE POST SIGN, F&I GM, 12-20 SF	3.00 AS	\$1,503.18	\$4,509.54
700-2-14	MULTI- POST SIGN, F&I GM, 31-50 SF	1.00 AS	\$5,637.01	\$5,637.01
700-2-15	MULTI- POST SIGN, F&I GM, 51-100 SF	1.00 AS	\$7,713.11	\$7,713.11
<b>Signing Component Total</b>				<b>\$18,239.88</b>

**INTELLIGENT TRAFFIC SYSTEM (ITS) COMPONENT**

**Description of Work**

**EX-Items**

Pay item	Description	Quantity Unit	Unit Price	Extended Amount
000-000	GENERAL ITS	874.00 LF	\$70.00	\$61,180.00
<b>Comment:</b> General ITS per LF of roadway.				
<b>Intelligent Traffic System (ITS) Component Total</b>				<b>\$61,180.00</b>

**LIGHTING COMPONENT**

**Rural Lighting Subcomponent**

Description	Value			
Multiplier (Number of Poles)	8			
<b>Pay Items</b>				
Pay item	Description	Quantity Unit	Unit Price	Extended Amount
630-2-11	CONDUIT, F& I, OPEN TRENCH	1,600.00 LF	\$9.76	\$15,616.00
635-2-11	PULL & SPLICE BOX, F&I, 13" x 24"	8.00 EA	\$767.98	\$6,143.84
715-1-13	LIGHTING CONDUCTORS, F&I, INSUL, NO.4-2	4,800.00 LF	\$2.62	\$12,576.00
715-4-14	LIGHT POLE COMPLETE, F&I-STD, 45'	8.00 EA	\$7,063.23	\$56,505.84
715-500-1	POLE CABLE DIST SYS, CONVENTIONAL	8.00 EA	\$621.64	\$4,973.12
<b>Subcomponent Total</b>				<b>\$95,814.80</b>
<b>Lighting Component Total</b>				<b>\$95,814.80</b>

**LANDSCAPING COMPONENT**

**User Input Data**

Description	Value
Cost %	2.00

**Landscaping Component Total**

\$37,250.01

**BRIDGES COMPONENT****Bridge 429-1**

<b>Description</b>	<b>Value</b>
Estimate Type	SF Estimate
Primary Estimate	YES
Length (LF)	136.00
Width (LF)	71.00
Type	Overpass Bridge
Cost Factor	1.50
Structure No.	
Removal of Existing Structures area	0.00
Default Cost per SF	\$120.00
Factored Cost per SF	\$180.00
<b>Final Cost per SF</b>	<b>\$192.87</b>
<b>Basic Bridge Cost</b>	<b>\$1,738,080.00</b>
Description	SOUTHBOUND SR 538 OVER SANDHILL RD

**Bridge Pay Items**

<b>Pay item</b>	<b>Description</b>	<b>Quantity</b>	<b>Unit</b>	<b>Unit Price</b>	<b>Extended Amount</b>
400-2-10	CONC CLASS II, APPROACH SLABS	157.78	CY	\$588.22	\$92,809.35
415-1-9	REINF STEEL- APPROACH SLABS	27,611.50	LB	\$1.14	\$31,477.11

**Bridge 429-1 Total** \$1,862,366.46

**Bridge 429-2**

<b>Description</b>	<b>Value</b>
Estimate Type	SF Estimate
Primary Estimate	YES
Length (LF)	141.00
Width (LF)	71.00
Type	Overpass Bridge
Cost Factor	1.50
Structure No.	
Removal of Existing Structures area	0.00
Default Cost per SF	\$120.00
Factored Cost per SF	\$180.00
<b>Final Cost per SF</b>	<b>\$192.41</b>
<b>Basic Bridge Cost</b>	<b>\$1,801,980.00</b>
Description	NORTHBOUND SR 538 OVER SANDHILL RD

**Bridge Pay Items**

<b>Pay item</b>	<b>Description</b>	<b>Quantity</b>	<b>Unit</b>	<b>Unit Price</b>	<b>Extended Amount</b>
400-2-10	CONC CLASS II, APPROACH SLABS	157.78	CY	\$588.22	\$92,809.35
415-1-9	REINF STEEL- APPROACH SLABS	27,611.50	LB	\$1.14	\$31,477.11

**Bridge 429-2 Total** \$1,926,266.46

**Bridges Component Total** \$3,788,632.92

**RETAINING WALLS COMPONENT**

**Retaining Wall 1**

<b>Description</b>	<b>Value</b>
Length	1,483.00
Begin height	17.50
End Height	17.50
Multiplier	2

**Pay Items**

<b>Pay item</b>	<b>Description</b>	<b>Quantity</b>	<b>Unit</b>	<b>Unit Price</b>	<b>Extended Amount</b>
548-12	RET WALL SYSTEM, PERM, EX BARRIER	51,905.00	SF	\$36.17	\$1,877,403.85
<b>Retaining Walls Component Total</b>					<b>\$1,877,403.86</b>

---

**Sequence 7 Total** **\$9,393,205.90**

---

Sequence: 8 NDR - New Construction, Divided, Rural

Net Length: 0.540 MI  
2,851 LF

Description: SR 429 Mainline. 8-LANE DIVIDED, RURAL. MEDIAN BARRIER AND OUTSIDE SHOULDER BARRIER. 4-LANES SB/4-LANES+1 AUX NB

### EARTHWORK COMPONENT

#### User Input Data

Description	Value
Standard Clearing and Grubbing Limits L/R	155.00 / 155.00
Incidental Clearing and Grubbing Area	0.00
Alignment Number	1
Distance	0.540
Top of Structural Course For Begin Section	105.00
Top of Structural Course For End Section	105.00
Horizontal Elevation For Begin Section	100.00
Horizontal Elevation For End Section	100.00
Front Slope L/R	6 to 1 / 6 to 1
Median Slope L/R	6 to 1 / 6 to 1
Median Shoulder Cross Slope L/R	5.00 % / 5.00 %
Outside Shoulder Cross Slope L/R	6.00 % / 6.00 %
Roadway Cross Slope L/R	2.00 % / 2.00 %

#### Pay Items

Pay item	Description	Quantity	Unit	Unit Price	Extended Amount
110-1-1	CLEARING & GRUBBING	20.29	AC	\$21,000.00	\$426,090.00
120-6	EMBANKMENT	63,024.19	CY	\$20.88	\$1,315,945.09
<b>Earthwork Component Total</b>					<b>\$1,742,035.09</b>

### ROADWAY COMPONENT

#### User Input Data

Description	Value
Number of Lanes	6
Roadway Pavement Width L/R	48.00 / 48.00
Structural Spread Rate	440
Friction Course Spread Rate	80

#### Pay Items

Pay item	Description	Quantity	Unit	Unit Price	Extended Amount
160-4	TYPE B STABILIZATION	48,787.20	SY	\$11.66	\$568,858.75
285-712	OPTIONAL BASE, BASE GROUP 12	30,830.98	SY	\$73.16	\$2,255,594.50
334-1-13	SUPERPAVE ASPHALTIC CONC, TRAFFIC C	6,690.82	TN	\$126.72	\$847,860.71
337-7-25	ASPH CONC FC, INC BIT, FC-5, PG76-22	1,216.51	TN	\$159.94	\$194,568.61

#### Pavement Marking Subcomponent

Description	Value
Include Thermo/Tape/Other	Y
Pavement Type	Asphalt
Solid Stripe No. of Paint Applications	1
Solid Stripe No. of Stripes	4
Skip Stripe No. of Paint Applications	1
Skip Stripe No. of Stripes	4



**Pay Items**

Pay item	Description	Quantity Unit	Unit Price	Extended Amount
706-1-1	RAISED PAVMT MARK, TYPE B W/O FINAL SURF	364.00 EA	\$3.58	\$1,303.12
710-11-101	PAINTED PAVT MARK,STD,WHITE,SOLID,6"	2.16 GM	\$1,080.33	\$2,333.51
710-11-131	PAINTED PAVT MARK,STD,WHITE,SKIP, 6"	2.16 GM	\$460.80	\$995.33
711-15-101	THERMOPLASTIC, STD-OP, WHITE, SOLID, 6"	2.16 GM	\$4,966.76	\$10,728.20
711-15-131	THERMOPLASTIC, STD-OP, WHITE, SKIP, 6"	2.16 GM	\$1,845.33	\$3,985.91
711-15-201	THERMOPLASTIC, STD-OP,YELLOW, SOLID, 6"	2.16 GM	\$4,988.35	\$10,774.84

**Peripherals Subcomponent**

Description	Value
Off Road Bike Path(s)	0
Off Road Bike Path Width L/R	0.00 / 0.00
Bike Path Structural Spread Rate	0
Noise Barrier Wall Length	0.00
Noise Barrier Wall Begin Height	0.00
Noise Barrier Wall End Height	0.00

**Pay Items**

Pay item	Description	Quantity Unit	Unit Price	Extended Amount
521-72-40	SHLDR CONC BARRIER,38" OR 44" HEIGHT	5,700.00 LF	\$306.25	\$1,745,625.00
550-10-120	FENCING, TYPE A, 5.1-6.0, STANDARD	5,702.00 LF	\$9.26	\$52,800.52

**Roadway Component Total**

\$5,695,429.00

**SHOULDER COMPONENT****User Input Data**

Description	Value
Total Outside Shoulder Width L/R	12.00 / 12.00
Total Outside Shoulder Perf. Turf Width L/R	2.00 / 0.00
Paved Outside Shoulder Width L/R	10.00 / 12.00
Structural Spread Rate	220
Friction Course Spread Rate	80
Total Width (T) / 8" Overlap (O)	0
Rumble Strips 1/2No. of Sides	2

**Pay Items**

Pay item	Description	Quantity Unit	Unit Price	Extended Amount
285-705	OPTIONAL BASE,BASE GROUP 05	7,178.69 SY	\$40.53	\$290,952.31
334-1-13	SUPERPAVE ASPHALTIC CONC, TRAFFIC C	766.66 TN	\$126.72	\$97,151.16
337-7-25	ASPH CONC FC,INC BIT,FC-5,PG76-22	16.73 TN	\$159.94	\$2,675.80
546-72-1	GROUND-IN RUMBLE STRIPS, 16"	1.08 GM	\$881.71	\$952.25
570-1-1	PERFORMANCE TURF	633.60 SY	\$3.19	\$2,021.18

**Erosion Control****Pay Items**

Pay item	Description	Quantity Unit	Unit Price	Extended Amount
----------	-------------	---------------	------------	-----------------

104-10-3	SEDIMENT BARRIER	7,413.12 LF	\$1.20	\$8,895.74
104-11	FLOATING TURBIDITY BARRIER	135.00 LF	\$9.49	\$1,281.15
104-12	STAKED TURBIDITY BARRIER- NYL REINF PVC	135.00 LF	\$4.44	\$599.40
104-15	SOIL TRACKING PREVENTION DEVICE	1.00 EA	\$2,988.11	\$2,988.11
104-18	INLET PROTECTION SYSTEM	4.00 EA	\$88.37	\$353.48
107-1	LITTER REMOVAL	13.09 AC	\$20.76	\$271.75
107-2	MOWING	13.09 AC	\$46.89	\$613.79
<b>Shoulder Component Total</b>				<b>\$408,756.12</b>

### MEDIAN COMPONENT

#### User Input Data

Description	Value
Total Median Width	34.00
Performance Turf Width	0.00
Total Median Shoulder Width L/R	17.00 / 17.00
Paved Median Shoulder Width L/R	17.00 / 17.00
Structural Spread Rate	220
Friction Course Spread Rate	80
Total Width (T) / 8" Overlap (O)	T
Rumble Strips $\bar{i}$ $\frac{1}{2}$ No. of Sides	2

#### Pay Items

Pay item	Description	Quantity Unit	Unit Price	Extended Amount
285-705	OPTIONAL BASE,BASE GROUP 05	10,980.29 SY	\$40.53	\$445,031.15
334-1-13	SUPERPAVE ASPHALTIC CONC, TRAFFIC C	1,184.83 TN	\$126.72	\$150,141.66
337-7-25	ASPH CONC FC,INC BIT,FC- 5,PG76-22	430.85 TN	\$159.94	\$68,910.15
521-1-11	MEDIAN CONC BARRIER, 38" HEIGHT	2,850.00 LF	\$316.17	\$901,084.50
546-72-1	GROUND-IN RUMBLE STRIPS, 16"	1.00 GM	\$881.71	\$881.71
<b>Median Component Total</b>				<b>\$1,566,049.17</b>

### DRAINAGE COMPONENT

#### Pay Items

Pay item	Description	Quantity Unit	Unit Price	Extended Amount
425-1-551	INLETS, DT BOT, TYPE E, <10'	4.00 EA	\$13,191.95	\$52,767.80
430-174-124	PIPE CULV, OPT MATL, ROUND,24"SD	432.00 LF	\$126.21	\$54,522.72
430-175-124	PIPE CULV, OPT MATL, ROUND, 24"S/CD	192.00 LF	\$128.82	\$24,733.44
430-175-136	PIPE CULV, OPT MATL, ROUND, 36"S/CD	160.00 LF	\$342.26	\$54,761.60
430-984-129	MITERED END SECT, OPTIONAL RD, 24" SD	22.00 EA	\$2,253.96	\$49,587.12
524-1-1	CONCRETE DITCH PAVT, NR, 3"	1,080.00 SY	\$218.44	\$235,915.20
570-1-1	PERFORMANCE TURF	380.16 SY	\$3.19	\$1,212.71

#### X-Items

Pay item	Description	Quantity Unit	Unit Price	Extended Amount
----------	-------------	---------------	------------	-----------------

425-1-921	INLETS, ADJACENT BARRIER, <=10'	29.00 EA	\$5,906.88	\$171,299.52
-----------	------------------------------------	----------	------------	--------------

<b>Drainage Component Total</b>				<b>\$644,800.11</b>
---------------------------------	--	--	--	---------------------

---

**SIGNING COMPONENT**

**Pay Items**

<b>Pay item</b>	<b>Description</b>	<b>Quantity Unit</b>	<b>Unit Price</b>	<b>Extended Amount</b>
700-1-11	SINGLE POST SIGN, F&I GM, <12 SF	2.00 AS	\$380.22	\$760.44
700-1-12	SINGLE POST SIGN, F&I GM, 12-20 SF	13.00 AS	\$1,503.18	\$19,541.34
700-2-14	MULTI- POST SIGN, F&I GM, 31-50 SF	2.00 AS	\$5,637.01	\$11,274.02
700-2-15	MULTI- POST SIGN, F&I GM, 51-100 SF	4.00 AS	\$7,713.11	\$30,852.44

**X-Items**

<b>Pay item</b>	<b>Description</b>	<b>Quantity Unit</b>	<b>Unit Price</b>	<b>Extended Amount</b>
700-4-114	OH STATIC SIGN STR, F&I, C 41-50 FT	2.00 EA	\$94,981.18	\$189,962.36
700-4-127	OH STATIC SIGN STR, F&I, S 151-200 FT	1.00 EA	\$211,285.18	\$211,285.18

<b>Signing Component Total</b>				<b>\$463,675.78</b>
--------------------------------	--	--	--	---------------------

---

**INTELLIGENT TRAFFIC SYSTEM (ITS) COMPONENT**

**Description of Work**

**EX-Items**

<b>Pay item</b>	<b>Description</b>	<b>Quantity Unit</b>	<b>Unit Price</b>	<b>Extended Amount</b>
000-000	GENERAL ITS	2,851.00 LF	\$70.00	\$199,570.00

<b>Intelligent Traffic System (ITS) Component Total</b>				<b>\$199,570.00</b>
---	--	--	--	---------------------

---

**LIGHTING COMPONENT**

**Rural Lighting Subcomponent**

**Description**

Multiplier (Number of Poles)

**Value**

30

**Pay Items**

<b>Pay item</b>	<b>Description</b>	<b>Quantity Unit</b>	<b>Unit Price</b>	<b>Extended Amount</b>
630-2-11	CONDUIT, F& I, OPEN TRENCH	6,000.00 LF	\$9.76	\$58,560.00
635-2-11	PULL & SPLICE BOX, F&I, 13" x 24"	30.00 EA	\$767.98	\$23,039.40
715-1-13	LIGHTING CONDUCTORS, F&I, INSUL, NO.4-2	18,000.00 LF	\$2.62	\$47,160.00
715-4-14	LIGHT POLE COMPLETE, F&I-STD, 45'	30.00 EA	\$7,063.23	\$211,896.90
715-500-1	POLE CABLE DIST SYS, CONVENTIONAL	30.00 EA	\$621.64	\$18,649.20
<b>Subcomponent Total</b>				<b>\$359,305.50</b>

<b>Lighting Component Total</b>				<b>\$359,305.50</b>
---------------------------------	--	--	--	---------------------

---

**LANDSCAPING COMPONENT**

**User Input Data**

<b>Description</b>	<b>Value</b>
Cost %	2.00
Component Detail	N

---

<b>Landscaping Component Total</b>	<b>\$166,300.69</b>
------------------------------------	---------------------

---

<b>Sequence 8 Total</b>	<b>\$11,245,921.46</b>
-------------------------	------------------------

---

Sequence: 9 NUR - New Construction, Undivided, Rural

Net Length: 0.160 MI  
846 LF

Description: CR 532 Ramp A: 2-Lane Off Ramp from SB SR 538 to CR 532

### EARTHWORK COMPONENT

#### User Input Data

Description	Value
Standard Clearing and Grubbing Limits L/R	50.00 / 94.00
Incidental Clearing and Grubbing Area	0.00
Alignment Number	1
Distance	0.160
Top of Structural Course For Begin Section	105.00
Top of Structural Course For End Section	105.00
Horizontal Elevation For Begin Section	100.00
Horizontal Elevation For End Section	100.00
Front Slope L/R	6 to 1 / 6 to 1
Outside Shoulder Cross Slope L/R	5.00 % / 6.00 %
Roadway Cross Slope L/R	2.00 % / 2.00 %

#### Pay Items

Pay item	Description	Quantity	Unit	Unit Price	Extended Amount
110-1-1	CLEARING & GRUBBING	2.79	AC	\$21,000.00	\$58,590.00
120-6	EMBANKMENT	8,620.71	CY	\$20.88	\$180,000.42
<b>Earthwork Component Total</b>					<b>\$238,590.42</b>

### ROADWAY COMPONENT

#### User Input Data

Description	Value
Number of Lanes	2
Roadway Pavement Width L/R	12.00 / 12.00
Structural Spread Rate	440
Friction Course Spread Rate	165

#### Pay Items

Pay item	Description	Quantity	Unit	Unit Price	Extended Amount
160-4	TYPE B STABILIZATION	4,135.30	SY	\$11.66	\$48,217.60
285-712	OPTIONAL BASE,BASE GROUP 12	2,317.65	SY	\$73.16	\$169,559.27
334-1-53	SUPERPAVE ASPH CONC, TRAF C, PG76-22	496.24	TN	\$127.05	\$63,047.29
337-7-83	ASPH CONC FC,TRAFFIC C,FC-12.5,PG 76-22	186.09	TN	\$122.75	\$22,842.55

#### Pavement Marking Subcomponent

Description	Value
Include Thermo/Tape/Other	Y
Pavement Type	Asphalt
Solid Stripe No. of Paint Applications	1
Solid Stripe No. of Stripes	2
Skip Stripe No. of Paint Applications	1
Skip Stripe No. of Stripes	1

#### Pay Items

Pay item	Description	Quantity	Unit	Unit Price	Extended Amount
----------	-------------	----------	------	------------	-----------------

706-1-1	RAISED PAVMT MARK, TYPE B W/O FINAL SURF	22.00 EA	\$3.58	\$78.76
710-11-101	PAINTED PAVT MARK,STD,WHITE,SOLID,6"	0.32 GM	\$1,080.33	\$345.71
710-11-231	PAINTED PAVT MARK,STD,YELLOW,SKIP,6"	0.16 GM	\$487.22	\$77.96
711-15-201	THERMOPLASTIC, STD- OP,YELLOW, SOLID, 6"	0.32 GM	\$4,988.35	\$1,596.27
711-16-101	THERMOPLASTIC, STD-OTH, WHITE, SOLID, 6"	0.32 GM	\$3,986.79	\$1,275.77
711-16-231	THERMOPLASTIC, STD-OTH, YELLOW, SKIP, 6"	0.16 GM	\$1,339.37	\$214.30

**Peripherals Subcomponent**

Description	Value
Off Road Bike Path(s)	0
Off Road Bike Path Width L/R	0.00 / 0.00
Bike Path Structural Spread Rate	0
Noise Barrier Wall Length	0.00
Noise Barrier Wall Begin Height	0.00
Noise Barrier Wall End Height	0.00

**Roadway Component Total** \$307,255.48

**SHOULDER COMPONENT**

**User Input Data**

Description	Value
Total Outside Shoulder Width L/R	8.00 / 12.00
Total Outside Shoulder Perf. Turf Width L/R	4.00 / 2.00
Paved Outside Shoulder Width L/R	4.00 / 10.00
Structural Spread Rate	220
Friction Course Spread Rate	165
Total Width (T) / 8" Overlap (O)	T
Rumble Strips $\frac{1}{2}$ No. of Sides	2

**Pay Items**

Pay item	Description	Quantity	Unit	Unit Price	Extended Amount
285-705	OPTIONAL BASE,BASE GROUP 05	1,377.81	SY	\$40.53	\$55,842.64
334-1-53	SUPERPAVE ASPH CONC, TRAF C, PG76-22	144.74	TN	\$127.05	\$18,389.22
337-7-83	ASPH CONC FC,TRAFFIC C,FC- 12.5,PG 76-22	108.55	TN	\$122.75	\$13,324.51
546-72-1	GROUND-IN RUMBLE STRIPS, 16"	0.32	GM	\$881.71	\$282.15
570-1-1	PERFORMANCE TURF	563.90	SY	\$3.19	\$1,798.84

**Erosion Control**

**Pay Items**

Pay item	Description	Quantity	Unit	Unit Price	Extended Amount
104-10-3	SEDIMENT BARRIER	2,199.23	LF	\$1.20	\$2,639.08
104-11	FLOATING TURBIDITY BARRIER	40.05	LF	\$9.49	\$380.07
104-12	STAKED TURBIDITY BARRIER- NYL REINF PVC	40.05	LF	\$4.44	\$177.82
104-15	SOIL TRACKING PREVENTION DEVICE	1.00	EA	\$2,988.11	\$2,988.11
107-1	LITTER REMOVAL	1.94	AC	\$20.76	\$40.27
107-2	MOWING	1.94	AC	\$46.89	\$90.97



Shoulder Component Total

\$95,953.68

**DRAINAGE COMPONENT**

**Pay Items**

Pay item	Description	Quantity	Unit	Unit Price	Extended Amount
430-174-124	PIPE CULV, OPT MATL, ROUND,24"SD	136.00	LF	\$126.21	\$17,164.56
430-175-136	PIPE CULV, OPT MATL, ROUND, 36"S/CD	32.00	LF	\$342.26	\$10,952.32
430-984-129	MITERED END SECT, OPTIONAL RD, 24" SD	7.00	EA	\$2,253.96	\$15,777.72
570-1-1	PERFORMANCE TURF	112.78	SY	\$3.19	\$359.77
<b>Drainage Component Total</b>					<b>\$44,254.37</b>

**SIGNING COMPONENT**

**Pay Items**

Pay item	Description	Quantity	Unit	Unit Price	Extended Amount
700-1-11	SINGLE POST SIGN, F&I GM, <12 SF	1.00	AS	\$380.22	\$380.22
700-1-12	SINGLE POST SIGN, F&I GM, 12-20 SF	4.00	AS	\$1,503.18	\$6,012.72
700-2-14	MULTI- POST SIGN, F&I GM, 31-50 SF	1.00	AS	\$5,637.01	\$5,637.01
<b>Signing Component Total</b>					<b>\$12,029.95</b>

**INTELLIGENT TRAFFIC SYSTEM (ITS) COMPONENT**

**Description of Work**

General ITS per LF of roadway.

**EX-Items**

Pay item	Description	Quantity	Unit	Unit Price	Extended Amount
000-000	GENERAL ITS	846.00	LF	\$70.00	\$59,220.00
<b>Comment:</b> General ITS per LF of roadway.					
<b>Intelligent Traffic System (ITS) Component Total</b>					<b>\$59,220.00</b>

**LIGHTING COMPONENT**

**Rural Lighting Subcomponent**

**Description**

Multiplier (Number of Poles)

**Value**

5

**Pay Items**

Pay item	Description	Quantity	Unit	Unit Price	Extended Amount
630-2-11	CONDUIT, F& I, OPEN TRENCH	1,000.00	LF	\$9.76	\$9,760.00
635-2-11	PULL & SPLICE BOX, F&I, 13" x 24"	5.00	EA	\$767.98	\$3,839.90
715-1-13	LIGHTING CONDUCTORS, F&I, INSUL, NO.4-2	3,000.00	LF	\$2.62	\$7,860.00
715-4-14	LIGHT POLE COMPLETE, F&I-STD, 45'	5.00	EA	\$7,063.23	\$35,316.15
715-500-1	POLE CABLE DIST SYS, CONVENTIONAL	5.00	EA	\$621.64	\$3,108.20

**Subcomponent Total** \$59,884.25

**Lighting Component Total** \$59,884.25

---

**LANDSCAPING COMPONENT**

**User Input Data**

<b>Description</b>	<b>Value</b>
Cost %	2.00
Component Detail	N

**Landscaping Component Total** \$8,949.27

---

**Sequence 9 Total** \$826,137.42

---

Sequence: 10 NUR - New Construction, Undivided, Rural

Net Length: 0.142 MI  
752 LF

Description: CR 532 Ramp A: 1-Lane Off Ramp from SB SR 538 to CR 532.

### EARTHWORK COMPONENT

#### User Input Data

Description	Value
Standard Clearing and Grubbing Limits L/R	50.00 / 94.00
Incidental Clearing and Grubbing Area	0.00
Alignment Number	1
Distance	0.142
Top of Structural Course For Begin Section	105.00
Top of Structural Course For End Section	105.00
Horizontal Elevation For Begin Section	100.00
Horizontal Elevation For End Section	100.00
Front Slope L/R	6 to 1 / 6 to 1
Outside Shoulder Cross Slope L/R	5.00 % / 6.00 %
Roadway Cross Slope L/R	2.00 % / 2.00 %

#### Pay Items

Pay item	Description	Quantity	Unit	Unit Price	Extended Amount
110-1-1	CLEARING & GRUBBING	2.48	AC	\$21,000.00	\$52,080.00
120-6	EMBANKMENT	3,772.13	CY	\$20.88	\$78,762.07
<b>Earthwork Component Total</b>					<b>\$130,842.07</b>

### ROADWAY COMPONENT

#### User Input Data

Description	Value
Number of Lanes	1
Roadway Pavement Width L/R	0.00 / 15.00
Structural Spread Rate	440
Friction Course Spread Rate	165

#### Pay Items

Pay item	Description	Quantity	Unit	Unit Price	Extended Amount
160-4	TYPE B STABILIZATION	2,255.62	SY	\$11.66	\$26,300.53
285-712	OPTIONAL BASE,BASE GROUP 12	1,280.69	SY	\$73.16	\$93,695.28
334-1-53	SUPERPAVE ASPH CONC, TRAF C, PG76-22	275.69	TN	\$127.05	\$35,026.41
337-7-83	ASPH CONC FC,TRAFFIC C,FC-12.5,PG 76-22	103.38	TN	\$122.75	\$12,689.90

#### Pavement Marking Subcomponent

Description	Value
Include Thermo/Tape/Other	Y
Pavement Type	Asphalt
Solid Stripe No. of Paint Applications	1
Solid Stripe No. of Stripes	2
Skip Stripe No. of Paint Applications	1
Skip Stripe No. of Stripes	0

#### Pay Items

Pay item	Description	Quantity	Unit	Unit Price	Extended Amount
----------	-------------	----------	------	------------	-----------------

710-11-101	PAINTED PAVT MARK,STD,WHITE,SOLID,6"	0.28 GM	\$1,080.33	\$302.49
711-15-201	THERMOPLASTIC, STD- OP,YELLOW, SOLID, 6"	0.28 GM	\$4,988.35	\$1,396.74
711-16-101	THERMOPLASTIC, STD-OTH, WHITE, SOLID, 6"	0.28 GM	\$3,986.79	\$1,116.30

#### Peripherals Subcomponent

Description	Value
Off Road Bike Path(s)	0
Off Road Bike Path Width L/R	0.00 / 0.00
Bike Path Structural Spread Rate	0
Noise Barrier Wall Length	0.00
Noise Barrier Wall Begin Height	0.00
Noise Barrier Wall End Height	0.00

#### Roadway Component Total

\$170,527.65

### SHOULDER COMPONENT

#### User Input Data

Description	Value
Total Outside Shoulder Width L/R	6.00 / 6.00
Total Outside Shoulder Perf. Turf Width L/R	4.00 / 2.00
Paved Outside Shoulder Width L/R	2.00 / 4.00
Structural Spread Rate	220
Friction Course Spread Rate	165
Total Width (T) / 8" Overlap (O)	T
Rumble Strips $i_c$ 1/2 No. of Sides	2

#### Pay Items

Pay item	Description	Quantity	Unit	Unit Price	Extended Amount
285-705	OPTIONAL BASE,BASE GROUP 05	556.39	SY	\$40.53	\$22,550.49
334-1-53	SUPERPAVE ASPH CONC, TRAF C, PG76-22	55.14	TN	\$127.05	\$7,005.54
337-7-83	ASPH CONC FC,TRAFFIC C,FC- 12.5,PG 76-22	41.35	TN	\$122.75	\$5,075.71
546-72-1	GROUND-IN RUMBLE STRIPS, 16"	0.28	GM	\$881.71	\$246.88
570-1-1	PERFORMANCE TURF	501.25	SY	\$3.19	\$1,598.99

#### Erosion Control

#### Pay Items

Pay item	Description	Quantity	Unit	Unit Price	Extended Amount
104-10-3	SEDIMENT BARRIER	1,954.87	LF	\$1.20	\$2,345.84
104-11	FLOATING TURBIDITY BARRIER	35.60	LF	\$9.49	\$337.84
104-12	STAKED TURBIDITY BARRIER- NYL REINF PVC	35.60	LF	\$4.44	\$158.06
104-15	SOIL TRACKING PREVENTION DEVICE	1.00	EA	\$2,988.11	\$2,988.11
107-1	LITTER REMOVAL	1.73	AC	\$20.76	\$35.91
107-2	MOWING	1.73	AC	\$46.89	\$81.12

#### Shoulder Component Total

\$42,424.49

### DRAINAGE COMPONENT

#### Pay Items

Pay item	Description	Quantity	Unit	Unit Price	Extended Amount
430-174-124	PIPE CULV, OPT MATL, ROUND,24"SD	120.00	LF	\$126.21	\$15,145.20
430-175-136	PIPE CULV, OPT MATL, ROUND, 36"S/CD	24.00	LF	\$342.26	\$8,214.24
430-984-129	MITERED END SECT, OPTIONAL RD, 24" SD	6.00	EA	\$2,253.96	\$13,523.76
570-1-1	PERFORMANCE TURF	100.25	SY	\$3.19	\$319.80
<b>Drainage Component Total</b>					<b>\$37,203.00</b>

#### SIGNING COMPONENT

Pay Items	Pay item	Description	Quantity	Unit	Unit Price	Extended Amount
	700-1-11	SINGLE POST SIGN, F&I GM, <12 SF	1.00	AS	\$380.22	\$380.22
	700-1-12	SINGLE POST SIGN, F&I GM, 12-20 SF	3.00	AS	\$1,503.18	\$4,509.54
	700-2-14	MULTI- POST SIGN, F&I GM, 31-50 SF	1.00	AS	\$5,637.01	\$5,637.01
<b>Signing Component Total</b>						<b>\$10,526.77</b>

#### INTELLIGENT TRAFFIC SYSTEM (ITS) COMPONENT

##### Description of Work

General ITS per LF of roadway.

##### EX-Items

Pay item	Description	Quantity	Unit	Unit Price	Extended Amount
000-000	GENERAL ITS	752.00	LF	\$70.00	\$52,640.00
<b>Comment:</b> General ITS per LF of roadway.					
<b>Intelligent Traffic System (ITS) Component Total</b>					<b>\$52,640.00</b>

#### LIGHTING COMPONENT

##### Rural Lighting Subcomponent

Description	Value					
Multiplier (Number of Poles)	4					
Pay Items	Pay item	Description	Quantity	Unit	Unit Price	Extended Amount
	630-2-11	CONDUIT, F& I, OPEN TRENCH	800.00	LF	\$9.76	\$7,808.00
	635-2-11	PULL & SPLICE BOX, F&I, 13" x 24"	4.00	EA	\$767.98	\$3,071.92
	715-1-13	LIGHTING CONDUCTORS, F&I, INSUL, NO.4-2	2,400.00	LF	\$2.62	\$6,288.00
	715-4-14	LIGHT POLE COMPLETE, F&I-STD, 45'	4.00	EA	\$7,063.23	\$28,252.92
	715-500-1	POLE CABLE DIST SYS, CONVENTIONAL	4.00	EA	\$621.64	\$2,486.56
<b>Subcomponent Total</b>						<b>\$47,907.40</b>
<b>Lighting Component Total</b>						<b>\$47,907.40</b>

**LANDSCAPING COMPONENT**

**User Input Data**

<b>Description</b>	<b>Value</b>
Cost %	2.00
Component Detail	N

---

<b>Landscaping Component Total</b>	<b>\$5,003.10</b>
------------------------------------	-------------------

---

<b>Sequence 10 Total</b>	<b>\$497,074.48</b>
--------------------------	---------------------

---



Sequence: 11 NUR - New Construction, Undivided, Rural

Net Length: 0.160 MI  
846 LF

Description: CR 532 Ramp D: 2-Lane On Ramp to NB SR 538 from CR 532.

**EARTHWORK COMPONENT**

**User Input Data**

Description	Value
Standard Clearing and Grubbing Limits L/R	50.00 / 94.00
Incidental Clearing and Grubbing Area	0.00
Alignment Number	1
Distance	0.160
Top of Structural Course For Begin Section	105.00
Top of Structural Course For End Section	105.00
Horizontal Elevation For Begin Section	100.00
Horizontal Elevation For End Section	100.00
Front Slope L/R	6 to 1 / 6 to 1
Outside Shoulder Cross Slope L/R	5.00 % / 6.00 %
Roadway Cross Slope L/R	2.00 % / 2.00 %

**Pay Items**

Pay item	Description	Quantity	Unit	Unit Price	Extended Amount
110-1-1	CLEARING & GRUBBING	2.79	AC	\$21,000.00	\$58,590.00
120-6	EMBANKMENT	8,620.71	CY	\$20.88	\$180,000.42
<b>Earthwork Component Total</b>					<b>\$238,590.42</b>

**ROADWAY COMPONENT**

**User Input Data**

Description	Value
Number of Lanes	2
Roadway Pavement Width L/R	12.00 / 12.00
Structural Spread Rate	440
Friction Course Spread Rate	165

**Pay Items**

Pay item	Description	Quantity	Unit	Unit Price	Extended Amount
160-4	TYPE B STABILIZATION	4,135.30	SY	\$11.66	\$48,217.60
285-712	OPTIONAL BASE,BASE GROUP 12	2,317.65	SY	\$73.16	\$169,559.27
334-1-53	SUPERPAVE ASPH CONC, TRAF C, PG76-22	496.24	TN	\$127.05	\$63,047.29
337-7-83	ASPH CONC FC,TRAFFIC C,FC-12.5,PG 76-22	186.09	TN	\$122.75	\$22,842.55

**Pavement Marking Subcomponent**

Description	Value
Include Thermo/Tape/Other	Y
Pavement Type	Asphalt
Solid Stripe No. of Paint Applications	1
Solid Stripe No. of Stripes	2
Skip Stripe No. of Paint Applications	1
Skip Stripe No. of Stripes	1

**Pay Items**

Pay item	Description	Quantity	Unit	Unit Price	Extended Amount
----------	-------------	----------	------	------------	-----------------

706-1-1	RAISED PAVMT MARK, TYPE B W/O FINAL SURF	22.00 EA	\$3.58	\$78.76
710-11-101	PAINTED PAVT MARK,STD,WHITE,SOLID,6"	0.32 GM	\$1,080.33	\$345.71
710-11-231	PAINTED PAVT MARK,STD,YELLOW,SKIP,6"	0.16 GM	\$487.22	\$77.96
711-15-201	THERMOPLASTIC, STD- OP,YELLOW, SOLID, 6"	0.32 GM	\$4,988.35	\$1,596.27
711-16-101	THERMOPLASTIC, STD-OTH, WHITE, SOLID, 6"	0.32 GM	\$3,986.79	\$1,275.77
711-16-231	THERMOPLASTIC, STD-OTH, YELLOW, SKIP, 6"	0.16 GM	\$1,339.37	\$214.30

**Peripherals Subcomponent**

Description	Value
Off Road Bike Path(s)	0
Off Road Bike Path Width L/R	0.00 / 0.00
Bike Path Structural Spread Rate	0
Noise Barrier Wall Length	0.00
Noise Barrier Wall Begin Height	0.00
Noise Barrier Wall End Height	0.00

**Roadway Component Total** \$307,255.48

**SHOULDER COMPONENT**

**User Input Data**

Description	Value
Total Outside Shoulder Width L/R	8.00 / 12.00
Total Outside Shoulder Perf. Turf Width L/R	4.00 / 2.00
Paved Outside Shoulder Width L/R	4.00 / 10.00
Structural Spread Rate	220
Friction Course Spread Rate	165
Total Width (T) / 8" Overlap (O)	T
Rumble Strips $\frac{1}{2}$ No. of Sides	2

**Pay Items**

Pay item	Description	Quantity	Unit	Unit Price	Extended Amount
285-705	OPTIONAL BASE,BASE GROUP 05	1,377.81	SY	\$40.53	\$55,842.64
334-1-53	SUPERPAVE ASPH CONC, TRAF C, PG76-22	144.74	TN	\$127.05	\$18,389.22
337-7-83	ASPH CONC FC,TRAFFIC C,FC- 12.5,PG 76-22	108.55	TN	\$122.75	\$13,324.51
546-72-1	GROUND-IN RUMBLE STRIPS, 16"	0.32	GM	\$881.71	\$282.15
570-1-1	PERFORMANCE TURF	563.90	SY	\$3.19	\$1,798.84

**Erosion Control**

**Pay Items**

Pay item	Description	Quantity	Unit	Unit Price	Extended Amount
104-10-3	SEDIMENT BARRIER	2,199.23	LF	\$1.20	\$2,639.08
104-11	FLOATING TURBIDITY BARRIER	40.05	LF	\$9.49	\$380.07
104-12	STAKED TURBIDITY BARRIER- NYL REINF PVC	40.05	LF	\$4.44	\$177.82
104-15	SOIL TRACKING PREVENTION DEVICE	1.00	EA	\$2,988.11	\$2,988.11
107-1	LITTER REMOVAL	1.94	AC	\$20.76	\$40.27
107-2	MOWING	1.94	AC	\$46.89	\$90.97

Shoulder Component Total

\$95,953.68

**DRAINAGE COMPONENT**

**Pay Items**

Pay item	Description	Quantity	Unit	Unit Price	Extended Amount
430-174-124	PIPE CULV, OPT MATL, ROUND,24"SD	136.00	LF	\$126.21	\$17,164.56
430-175-136	PIPE CULV, OPT MATL, ROUND, 36"S/CD	32.00	LF	\$342.26	\$10,952.32
430-984-129	MITERED END SECT, OPTIONAL RD, 24" SD	7.00	EA	\$2,253.96	\$15,777.72
570-1-1	PERFORMANCE TURF	112.78	SY	\$3.19	\$359.77
<b>Drainage Component Total</b>					<b>\$44,254.37</b>

**SIGNING COMPONENT**

**Pay Items**

Pay item	Description	Quantity	Unit	Unit Price	Extended Amount
700-1-11	SINGLE POST SIGN, F&I GM, <12 SF	1.00	AS	\$380.22	\$380.22
700-1-12	SINGLE POST SIGN, F&I GM, 12-20 SF	4.00	AS	\$1,503.18	\$6,012.72
700-2-14	MULTI- POST SIGN, F&I GM, 31-50 SF	1.00	AS	\$5,637.01	\$5,637.01
<b>Signing Component Total</b>					<b>\$12,029.95</b>

**INTELLIGENT TRAFFIC SYSTEM (ITS) COMPONENT**

**Description of Work**

General ITS per LF of roadway.

**EX-Items**

Pay item	Description	Quantity	Unit	Unit Price	Extended Amount
000-000	GENERAL ITS	797.06	LF	\$70.00	\$55,794.20
<b>Comment:</b> General ITS per LF of roadway.					
<b>Intelligent Traffic System (ITS) Component Total</b>					<b>\$55,794.20</b>

**LIGHTING COMPONENT**

**Rural Lighting Subcomponent**

**Description**

Multiplier (Number of Poles)

**Value**

5

**Pay Items**

Pay item	Description	Quantity	Unit	Unit Price	Extended Amount
630-2-11	CONDUIT, F& I, OPEN TRENCH	1,000.00	LF	\$9.76	\$9,760.00
635-2-11	PULL & SPLICE BOX, F&I, 13" x 24"	5.00	EA	\$767.98	\$3,839.90
715-1-13	LIGHTING CONDUCTORS, F&I, INSUL, NO.4-2	3,000.00	LF	\$2.62	\$7,860.00
715-4-14	LIGHT POLE COMPLETE, F&I-STD, 45'	5.00	EA	\$7,063.23	\$35,316.15
715-500-1	POLE CABLE DIST SYS, CONVENTIONAL	5.00	EA	\$621.64	\$3,108.20

**Subcomponent Total** \$59,884.25

**Lighting Component Total** \$59,884.25

---

**LANDSCAPING COMPONENT**

**User Input Data**

<b>Description</b>	<b>Value</b>
Cost %	2.00
Component Detail	N

**Landscaping Component Total** \$8,949.27

---

**Sequence 11 Total** \$822,711.62

---

Sequence: 12 NUR - New Construction, Undivided, Rural

Net Length: 0.103 MI  
544 LF

Description: CR 532 Ramp D: 1-Lane On Ramp to NB 538 from CR 532

### EARTHWORK COMPONENT

#### User Input Data

Description	Value
Standard Clearing and Grubbing Limits L/R	50.00 / 94.00
Incidental Clearing and Grubbing Area	0.00
Alignment Number	1
Distance	0.103
Top of Structural Course For Begin Section	105.00
Top of Structural Course For End Section	105.00
Horizontal Elevation For Begin Section	100.00
Horizontal Elevation For End Section	100.00
Front Slope L/R	6 to 1 / 6 to 1
Outside Shoulder Cross Slope L/R	5.00 % / 6.00 %
Roadway Cross Slope L/R	2.00 % / 2.00 %

#### Pay Items

Pay item	Description	Quantity	Unit	Unit Price	Extended Amount
110-1-1	CLEARING & GRUBBING	1.80	AC	\$21,000.00	\$37,800.00
120-6	EMBANKMENT	2,736.12	CY	\$20.88	\$57,130.19
<b>Earthwork Component Total</b>					<b>\$94,930.19</b>

### ROADWAY COMPONENT

#### User Input Data

Description	Value
Number of Lanes	1
Roadway Pavement Width L/R	0.00 / 15.00
Structural Spread Rate	440
Friction Course Spread Rate	165

#### Pay Items

Pay item	Description	Quantity	Unit	Unit Price	Extended Amount
160-4	TYPE B STABILIZATION	1,631.52	SY	\$11.66	\$19,023.52
285-712	OPTIONAL BASE,BASE GROUP 12	926.34	SY	\$73.16	\$67,771.03
334-1-53	SUPERPAVE ASPH CONC, TRAF C, PG76-22	199.41	TN	\$127.05	\$25,335.04
337-7-83	ASPH CONC FC,TRAFFIC C,FC-12.5,PG 76-22	74.78	TN	\$122.75	\$9,179.25

#### Pavement Marking Subcomponent

Description	Value
Include Thermo/Tape/Other	Y
Pavement Type	Asphalt
Solid Stripe No. of Paint Applications	1
Solid Stripe No. of Stripes	2
Skip Stripe No. of Paint Applications	1
Skip Stripe No. of Stripes	0

#### Pay Items

Pay item	Description	Quantity	Unit	Unit Price	Extended Amount
----------	-------------	----------	------	------------	-----------------

710-11-101	PAINTED PAVT MARK,STD,WHITE,SOLID,6"	0.21 GM	\$1,080.33	\$226.87
711-15-201	THERMOPLASTIC, STD- OP,YELLOW, SOLID, 6"	0.21 GM	\$4,988.35	\$1,047.55
711-16-101	THERMOPLASTIC, STD-OTH, WHITE, SOLID, 6"	0.21 GM	\$3,986.79	\$837.23

#### Peripherals Subcomponent

Description	Value
Off Road Bike Path(s)	0
Off Road Bike Path Width L/R	0.00 / 0.00
Bike Path Structural Spread Rate	0
Noise Barrier Wall Length	0.00
Noise Barrier Wall Begin Height	0.00
Noise Barrier Wall End Height	0.00

#### Roadway Component Total

\$123,420.49

### SHOULDER COMPONENT

#### User Input Data

Description	Value
Total Outside Shoulder Width L/R	6.00 / 6.00
Total Outside Shoulder Perf. Turf Width L/R	4.00 / 2.00
Paved Outside Shoulder Width L/R	2.00 / 4.00
Structural Spread Rate	220
Friction Course Spread Rate	165
Total Width (T) / 8" Overlap (O)	T
Rumble Strips $i_c$ 1/2 No. of Sides	2

#### Pay Items

Pay item	Description	Quantity	Unit	Unit Price	Extended Amount
285-705	OPTIONAL BASE,BASE GROUP 05	402.44	SY	\$40.53	\$16,310.89
334-1-53	SUPERPAVE ASPH CONC, TRAF C, PG76-22	39.88	TN	\$127.05	\$5,066.75
337-7-83	ASPH CONC FC,TRAFFIC C,FC- 12.5,PG 76-22	29.91	TN	\$122.75	\$3,671.45
546-72-1	GROUND-IN RUMBLE STRIPS, 16"	0.21	GM	\$881.71	\$185.16
570-1-1	PERFORMANCE TURF	362.56	SY	\$3.19	\$1,156.57

#### Erosion Control

#### Pay Items

Pay item	Description	Quantity	Unit	Unit Price	Extended Amount
104-10-3	SEDIMENT BARRIER	1,413.98	LF	\$1.20	\$1,696.78
104-11	FLOATING TURBIDITY BARRIER	25.75	LF	\$9.49	\$244.37
104-12	STAKED TURBIDITY BARRIER- NYL REINF PVC	25.75	LF	\$4.44	\$114.33
104-15	SOIL TRACKING PREVENTION DEVICE	1.00	EA	\$2,988.11	\$2,988.11
107-1	LITTER REMOVAL	1.25	AC	\$20.76	\$25.95
107-2	MOWING	1.25	AC	\$46.89	\$58.61

#### Shoulder Component Total

\$31,518.97

### DRAINAGE COMPONENT

#### Pay Items



Pay item	Description	Quantity	Unit	Unit Price	Extended Amount
430-174-124	PIPE CULV, OPT MATL, ROUND,24"SD	88.00	LF	\$126.21	\$11,106.48
430-175-136	PIPE CULV, OPT MATL, ROUND, 36"S/CD	24.00	LF	\$342.26	\$8,214.24
430-984-129	MITERED END SECT, OPTIONAL RD, 24" SD	5.00	EA	\$2,253.96	\$11,269.80
570-1-1	PERFORMANCE TURF	72.51	SY	\$3.19	\$231.31
<b>Drainage Component Total</b>					<b>\$30,821.83</b>

### SIGNING COMPONENT

Pay Items	Pay item	Description	Quantity	Unit	Unit Price	Extended Amount
	700-1-11	SINGLE POST SIGN, F&I GM, <12 SF	1.00	AS	\$380.22	\$380.22
	700-1-12	SINGLE POST SIGN, F&I GM, 12-20 SF	3.00	AS	\$1,503.18	\$4,509.54
	700-2-14	MULTI- POST SIGN, F&I GM, 31-50 SF	1.00	AS	\$5,637.01	\$5,637.01
<b>Signing Component Total</b>						<b>\$10,526.77</b>

### INTELLIGENT TRAFFIC SYSTEM (ITS) COMPONENT

#### Description of Work

General ITS per LF of roadway.

#### EX-Items

Pay item	Description	Quantity	Unit	Unit Price	Extended Amount
000-000	GENERAL ITS	797.06	LF	\$70.00	\$55,794.20
<b>Comment:</b> General ITS per LF of roadway.					
<b>Intelligent Traffic System (ITS) Component Total</b>					<b>\$55,794.20</b>

### LIGHTING COMPONENT

#### Rural Lighting Subcomponent

Description	Value					
Multiplier (Number of Poles)	3					
Pay Items	Pay item	Description	Quantity	Unit	Unit Price	Extended Amount
	630-2-11	CONDUIT, F& I, OPEN TRENCH	600.00	LF	\$9.76	\$5,856.00
	635-2-11	PULL & SPLICE BOX, F&I, 13" x 24"	3.00	EA	\$767.98	\$2,303.94
	715-1-13	LIGHTING CONDUCTORS, F&I, INSUL, NO.4-2	1,800.00	LF	\$2.62	\$4,716.00
	715-4-14	LIGHT POLE COMPLETE, F&I-STD, 45'	3.00	EA	\$7,063.23	\$21,189.69
	715-500-1	POLE CABLE DIST SYS, CONVENTIONAL	3.00	EA	\$621.64	\$1,864.92
<b>Subcomponent Total</b>						<b>\$35,930.55</b>
<b>Lighting Component Total</b>						<b>\$35,930.55</b>

**LANDSCAPING COMPONENT**

**User Input Data**

<b>Description</b>	<b>Value</b>
Cost %	2.00
Component Detail	N

---

<b>Landscaping Component Total</b>	<b>\$3,715.23</b>
------------------------------------	-------------------

---

<b>Sequence 12 Total</b>	<b>\$386,658.23</b>
--------------------------	---------------------

---

Sequence: 13NUR - New Construction, Undivided, Rural

Net Length: 0.430 MI  
2,270 LF

Description: SR 538 Ramp A1: 1-Lane Ramp. NB SR 538 TO WB I-4 General Use Lanes. Includes Retaining Wall and Bridge R-A1.

**EARTHWORK COMPONENT**

**User Input Data**

Description	Value
Standard Clearing and Grubbing Limits L/R	50.00 / 94.00
Incidental Clearing and Grubbing Area	0.00
Alignment Number	1
Distance	0.430
Top of Structural Course For Begin Section	117.50
Top of Structural Course For End Section	117.50
Horizontal Elevation For Begin Section	100.00
Horizontal Elevation For End Section	100.00
Front Slope L/R	6 to 1 / 6 to 1
Outside Shoulder Cross Slope L/R	5.00 % / 6.00 %
Roadway Cross Slope L/R	2.00 % / 2.00 %

**Pay Items**

Pay item	Description	Quantity	Unit	Unit Price	Extended Amount
110-1-1	CLEARING & GRUBBING	7.51	AC	\$21,000.00	\$157,710.00
120-6	EMBANKMENT	100,197.80	CY	\$20.88	\$2,092,130.06
<b>Earthwork Component Total</b>					<b>\$2,249,840.06</b>

**ROADWAY COMPONENT**

**User Input Data**

Description	Value
Number of Lanes	1
Roadway Pavement Width L/R	0.00 / 15.00
Structural Spread Rate	440
Friction Course Spread Rate	165

**Pay Items**

Pay item	Description	Quantity	Unit	Unit Price	Extended Amount
160-4	TYPE B STABILIZATION	8,703.20	SY	\$11.66	\$101,479.31
285-712	OPTIONAL BASE,BASE GROUP 12	3,867.25	SY	\$73.16	\$282,928.01
334-1-53	SUPERPAVE ASPH CONC, TRAF C, PG76-22	832.48	TN	\$127.05	\$105,766.58
337-7-83	ASPH CONC FC,TRAFFIC C,FC-12.5,PG 76-22	312.18	TN	\$122.75	\$38,320.10

**Pavement Marking Subcomponent**

Description	Value
Include Thermo/Tape/Other	Y
Pavement Type	Asphalt
Solid Stripe No. of Paint Applications	1
Solid Stripe No. of Stripes	2
Skip Stripe No. of Paint Applications	1
Skip Stripe No. of Stripes	0

**Pay Items**

Pay item	Description	Quantity	Unit	Unit Price	Extended Amount
----------	-------------	----------	------	------------	-----------------

710-11-101	PAINTED PAVT MARK,STD,WHITE,SOLID,6"	0.86 GM	\$1,080.33	\$929.08
711-15-201	THERMOPLASTIC, STD- OP,YELLOW, SOLID, 6"	0.86 GM	\$4,988.35	\$4,289.98
711-16-101	THERMOPLASTIC, STD-OTH, WHITE, SOLID, 6"	0.86 GM	\$3,986.79	\$3,428.64

#### Peripherals Subcomponent

Description	Value
Off Road Bike Path(s)	0
Off Road Bike Path Width L/R	0.00 / 0.00
Bike Path Structural Spread Rate	0
Noise Barrier Wall Length	0.00
Noise Barrier Wall Begin Height	0.00
Noise Barrier Wall End Height	0.00

#### Pay Items

Pay item	Description	Quantity Unit	Unit Price	Extended Amount
521-72-40	SHLDR CONC BARRIER,38" OR 44" HEIGHT	2,438.00 LF	\$306.25	\$746,637.50

#### Roadway Component Total

\$1,283,779.20

### SHOULDER COMPONENT

#### User Input Data

Description	Value
Total Outside Shoulder Width L/R	13.50 / 6.00
Total Outside Shoulder Perf. Turf Width L/R	0.00 / 0.00
Paved Outside Shoulder Width L/R	13.50 / 6.00
Structural Spread Rate	220
Friction Course Spread Rate	165
Total Width (T) / 8" Overlap (O)	T
Rumble Strips i; ½No. of Sides	2

#### Pay Items

Pay item	Description	Quantity Unit	Unit Price	Extended Amount
285-705	OPTIONAL BASE,BASE GROUP 05	5,085.70 SY	\$40.53	\$206,123.42
334-1-53	SUPERPAVE ASPH CONC, TRAF C, PG76-22	541.11 TN	\$127.05	\$68,748.03
337-7-83	ASPH CONC FC,TRAFFIC C,FC- 12.5,PG 76-22	405.83 TN	\$122.75	\$49,815.63
546-72-1	GROUND-IN RUMBLE STRIPS, 16"	0.86 GM	\$881.71	\$758.27

#### X-Items

Pay item	Description	Quantity Unit	Unit Price	Extended Amount
521-8-7	CONC BARRIER, W/JUNCT SL, 36 SS	800.00 LF	\$303.07	\$242,456.00

#### Erosion Control

#### Pay Items

Pay item	Description	Quantity Unit	Unit Price	Extended Amount
104-10-3	SEDIMENT BARRIER	5,903.04 LF	\$1.20	\$7,083.65
104-11	FLOATING TURBIDITY BARRIER	107.50 LF	\$9.49	\$1,020.18
104-12	STAKED TURBIDITY BARRIER- NYL REINF PVC	107.50 LF	\$4.44	\$477.30

104-15	SOIL TRACKING PREVENTION DEVICE	1.00 EA	\$2,988.11	\$2,988.11
107-1	LITTER REMOVAL	5.21 AC	\$20.76	\$108.16
107-2	MOWING	5.21 AC	\$46.89	\$244.30
<b>Shoulder Component Total</b>				<b>\$579,823.05</b>

**DRAINAGE COMPONENT**

**Pay Items**

Pay item	Description	Quantity Unit	Unit Price	Extended Amount
430-174-124	PIPE CULV, OPT MATL, ROUND,24"SD	344.00 LF	\$126.21	\$43,416.24
430-175-136	PIPE CULV, OPT MATL, ROUND, 36"S/CD	80.00 LF	\$342.26	\$27,380.80
430-984-129	MITERED END SECT, OPTIONAL RD, 24" SD	18.00 EA	\$2,253.96	\$40,571.28
570-1-1	PERFORMANCE TURF	302.72 SY	\$3.19	\$965.68
<b>Drainage Component Total</b>				<b>\$112,334.00</b>

**SIGNING COMPONENT**

**Pay Items**

Pay item	Description	Quantity Unit	Unit Price	Extended Amount
700-1-11	SINGLE POST SIGN, F&I GM, <12 SF	1.00 AS	\$380.22	\$380.22
700-1-12	SINGLE POST SIGN, F&I GM, 12-20 SF	9.00 AS	\$1,503.18	\$13,528.62
700-2-14	MULTI- POST SIGN, F&I GM, 31-50 SF	1.00 AS	\$5,637.01	\$5,637.01
<b>Signing Component Total</b>				<b>\$19,545.85</b>

**INTELLIGENT TRAFFIC SYSTEM (ITS) COMPONENT**

**Description of Work**

General ITS per LF of roadway.

**EX-Items**

Pay item	Description	Quantity Unit	Unit Price	Extended Amount
000-000	GENERAL ITS	5,710.00 LF	\$70.00	\$399,700.00
<b>Comment:</b> General ITS per LF of roadway.				
<b>Intelligent Traffic System (ITS) Component Total</b>				<b>\$399,700.00</b>

**LIGHTING COMPONENT**

**Rural Lighting Subcomponent**

Description	Value
Multiplier (Number of Poles)	30

**Pay Items**

Pay item	Description	Quantity Unit	Unit Price	Extended Amount
630-2-11	CONDUIT, F& I, OPEN TRENCH	6,000.00 LF	\$9.76	\$58,560.00
635-2-11	PULL & SPLICE BOX, F&I, 13" x 24"	30.00 EA	\$767.98	\$23,039.40

715-1-13	LIGHTING CONDUCTORS, F&I, INSUL, NO.4-2	18,000.00 LF	\$2.62	\$47,160.00
715-4-14	LIGHT POLE COMPLETE, F&I- STD, 45'	30.00 EA	\$7,063.23	\$211,896.90
715-500-1	POLE CABLE DIST SYS, CONVENTIONAL	30.00 EA	\$621.64	\$18,649.20
	<b>Subcomponent Total</b>			\$359,305.50
	<b>Lighting Component Total</b>			\$359,305.50

### LANDSCAPING COMPONENT

#### User Input Data

Description	Value
Cost %	2.00
Component Detail	N

**Landscaping Component Total** \$39,518.73

### BRIDGES COMPONENT

#### Bridge R-A1

Description	Value
Estimate Type	SF Estimate
Primary Estimate	YES
Length (LF)	3,854.00
Width (LF)	38.00
Type	High Level
Cost Factor	2.04
Structure No.	
Removal of Existing Structures area	0.00
Default Cost per SF	\$135.00
Factored Cost per SF	\$275.40
<b>Final Cost per SF</b>	<b>\$275.85</b>
<b>Basic Bridge Cost</b>	<b>\$40,332,880.80</b>

Description SR 538 RAMP A1 BRIDGE. NB SR 538 TO WB I-4 GENERAL USE LANES.

#### Bridge Pay Items

Pay item	Description	Quantity	Unit	Unit Price	Extended Amount
400-2-10	CONC CLASS II, APPROACH SLABS	84.44	CY	\$588.22	\$49,669.30
415-1-9	REINF STEEL- APPROACH SLABS	14,777.00	LB	\$1.14	\$16,845.78
	<b>Bridge R-A1 Total</b>				\$40,399,395.88
	<b>Bridges Component Total</b>				\$40,399,395.88

### RETAINING WALLS COMPONENT

#### Retaining Wall 1

Description	Value
Length	872.00
Begin height	17.50
End Height	17.50
Multiplier	2



**Pay Items**

<b>Pay item</b>	<b>Description</b>	<b>Quantity</b>	<b>Unit</b>	<b>Unit Price</b>	<b>Extended Amount</b>
548-12	RET WALL SYSTEM, PERM, EX BARRIER	30,520.00	SF	\$36.17	\$1,103,908.40
<b>Retaining Walls Component Total</b>					\$1,103,908.40

---

**Sequence 13 Total** \$46,547,150.67

---

Sequence: 14 NUR - New Construction, Undivided, Rural

Net Length: 0.528 MI  
2,785 LF

Description: SR 429 Ramp A3: 1-Lane Ramp. SB SR 429 C-D Road to WB I-4 Express Lanes. Includes Retaining Wall and Bridge R-A2

**EARTHWORK COMPONENT**

**User Input Data**

Description	Value
Standard Clearing and Grubbing Limits L/R	50.00 / 50.00
Incidental Clearing and Grubbing Area	0.00
Alignment Number	1
Distance	0.530
Top of Structural Course For Begin Section	117.50
Top of Structural Course For End Section	117.50
Horizontal Elevation For Begin Section	100.00
Horizontal Elevation For End Section	100.00
Front Slope L/R	6 to 1 / 6 to 1
Outside Shoulder Cross Slope L/R	5.00 % / 6.00 %
Roadway Cross Slope L/R	2.00 % / 2.00 %

**Pay Items**

Pay item	Description	Quantity Unit	Unit Price	Extended Amount
110-1-1	CLEARING & GRUBBING	6.40 AC	\$21,000.00	\$134,400.00
120-6	EMBANKMENT	123,499.61 CY	\$20.88	\$2,578,671.86
<b>Earthwork Component Total</b>				<b>\$2,713,071.86</b>

**ROADWAY COMPONENT**

**User Input Data**

Description	Value
Number of Lanes	1
Roadway Pavement Width L/R	0.00 / 15.00
Structural Spread Rate	440
Friction Course Spread Rate	165

**Pay Items**

Pay item	Description	Quantity Unit	Unit Price	Extended Amount
160-4	TYPE B STABILIZATION	10,212.40 SY	\$11.66	\$119,076.58
285-712	OPTIONAL BASE,BASE GROUP 12	4,744.12 SY	\$73.16	\$347,079.82
334-1-53	SUPERPAVE ASPH CONC, TRAF C, PG76-22	1,021.24 TN	\$127.05	\$129,748.54
337-7-83	ASPH CONC FC,TRAFFIC C,FC-12.5,PG 76-22	382.96 TN	\$122.75	\$47,008.34

**Pavement Marking Subcomponent**

Description	Value
Include Thermo/Tape/Other	Y
Pavement Type	Asphalt
Solid Stripe No. of Paint Applications	1
Solid Stripe No. of Stripes	2
Skip Stripe No. of Paint Applications	1
Skip Stripe No. of Stripes	0

**Pay Items**

Pay item	Description	Quantity Unit	Unit Price	Extended Amount
----------	-------------	---------------	------------	-----------------

710-11-101	PAINTED PAVT MARK,STD,WHITE,SOLID,6"	1.06 GM	\$1,080.33	\$1,145.15
711-15-201	THERMOPLASTIC, STD- OP,YELLOW, SOLID, 6"	1.06 GM	\$4,988.35	\$5,287.65
711-16-101	THERMOPLASTIC, STD-OTH, WHITE, SOLID, 6"	1.06 GM	\$3,986.79	\$4,226.00

#### Peripherals Subcomponent

Description	Value
Off Road Bike Path(s)	0
Off Road Bike Path Width L/R	0.00 / 0.00
Bike Path Structural Spread Rate	0
Noise Barrier Wall Length	0.00
Noise Barrier Wall Begin Height	0.00
Noise Barrier Wall End Height	0.00

#### Pay Items

Pay item	Description	Quantity Unit	Unit Price	Extended Amount
521-72-40	SHLDR CONC BARRIER,38" OR 44" HEIGHT	1,830.00 LF	\$306.25	\$560,437.50

#### Roadway Component Total

\$1,214,009.58

### SHOULDER COMPONENT

#### User Input Data

Description	Value
Total Outside Shoulder Width L/R	12.00 / 6.00
Total Outside Shoulder Perf. Turf Width L/R	0.00 / 0.00
Paved Outside Shoulder Width L/R	12.00 / 6.00
Structural Spread Rate	220
Friction Course Spread Rate	165
Total Width (T) / 8" Overlap (O)	T
Rumble Strips i; ½No. of Sides	2

#### Pay Items

Pay item	Description	Quantity Unit	Unit Price	Extended Amount
285-705	OPTIONAL BASE,BASE GROUP 05	5,774.65 SY	\$40.53	\$234,046.56
334-1-53	SUPERPAVE ASPH CONC, TRAF C, PG76-22	612.74 TN	\$127.05	\$77,848.62
337-7-83	ASPH CONC FC,TRAFFIC C,FC- 12.5,PG 76-22	459.56 TN	\$122.75	\$56,410.99
546-72-1	GROUND-IN RUMBLE STRIPS, 16"	1.06 GM	\$881.71	\$934.61

#### X-Items

Pay item	Description	Quantity Unit	Unit Price	Extended Amount
521-8-7	CONC BARRIER, W/JUNCT SL, 36 SS	3,030.00 LF	\$303.07	\$918,302.10

#### Erosion Control

#### Pay Items

Pay item	Description	Quantity Unit	Unit Price	Extended Amount
104-10-3	SEDIMENT BARRIER	7,241.52 LF	\$1.20	\$8,689.82
104-11	FLOATING TURBIDITY BARRIER	131.88 LF	\$9.49	\$1,251.54
104-12	STAKED TURBIDITY BARRIER- NYL REINF PVC	131.88 LF	\$4.44	\$585.55

104-15	SOIL TRACKING PREVENTION DEVICE	1.00 EA	\$2,988.11	\$2,988.11
107-1	LITTER REMOVAL	6.39 AC	\$20.76	\$132.66
107-2	MOWING	6.39 AC	\$46.89	\$299.63
<b>Shoulder Component Total</b>				\$1,301,490.19

#### DRAINAGE COMPONENT

##### Pay Items

Pay item	Description	Quantity Unit	Unit Price	Extended Amount
430-174-124	PIPE CULV, OPT MATL, ROUND,24"SD	424.00 LF	\$126.21	\$53,513.04
430-175-136	PIPE CULV, OPT MATL, ROUND, 36"S/CD	88.00 LF	\$342.26	\$30,118.88
430-984-129	MITERED END SECT, OPTIONAL RD, 24" SD	22.00 EA	\$2,253.96	\$49,587.12
570-1-1	PERFORMANCE TURF	371.36 SY	\$3.19	\$1,184.64

##### X-Items

Pay item	Description	Quantity Unit	Unit Price	Extended Amount
425-1-921	INLETS, ADJACENT BARRIER, <=10'	13.00 EA	\$5,906.88	\$76,789.44
425-1-922	INLETS, ADJACENT BARRIER, >10'	12.00 EA	\$9,281.70	\$111,380.40

**Drainage Component Total** \$322,573.52

#### SIGNING COMPONENT

##### Pay Items

Pay item	Description	Quantity Unit	Unit Price	Extended Amount
700-1-11	SINGLE POST SIGN, F&I GM, <12 SF	2.00 AS	\$380.22	\$760.44
700-1-12	SINGLE POST SIGN, F&I GM, 12- 20 SF	11.00 AS	\$1,503.18	\$16,534.98
700-2-14	MULTI- POST SIGN, F&I GM, 31-50 SF	2.00 AS	\$5,637.01	\$11,274.02

##### X-Items

Pay item	Description	Quantity Unit	Unit Price	Extended Amount
700-4-114	OH STATIC SIGN STR, F&I, C 41- 50 FT	2.00 EA	\$94,981.18	\$189,962.36
700-4-127	OH STATIC SIGN STR, F&I, S 151- 200 FT	1.00 EA	\$211,285.18	\$211,285.18

**Signing Component Total** \$429,816.98

#### INTELLIGENT TRAFFIC SYSTEM (ITS) COMPONENT

##### Description of Work

General ITS per LF of roadway.

##### EX-Items

Pay item	Description	Quantity Unit	Unit Price	Extended Amount
000-000	GENERAL ITS	3,785.00 LF	\$70.00	\$264,950.00

**Comment:** General ITS per LF of roadway and Bridge in this sequence.

**Intelligent Traffic System (ITS) Component Total** \$264,950.00

**LIGHTING COMPONENT**

**Rural Lighting Subcomponent**

<b>Description</b>				<b>Value</b>	
Multiplier (Number of Poles)				20	
<b>Pay Items</b>					
<b>Pay item</b>	<b>Description</b>	<b>Quantity</b>	<b>Unit</b>	<b>Unit Price</b>	<b>Extended Amount</b>
630-2-11	CONDUIT, F& I, OPEN TRENCH	4,000.00	LF	\$9.76	\$39,040.00
635-2-11	PULL & SPLICE BOX, F&I, 13" x 24"	20.00	EA	\$767.98	\$15,359.60
715-1-13	LIGHTING CONDUCTORS, F&I, INSUL, NO.4-2	12,000.00	LF	\$2.62	\$31,440.00
715-4-14	LIGHT POLE COMPLETE, F&I-STD, 45'	20.00	EA	\$7,063.23	\$141,264.60
715-500-1	POLE CABLE DIST SYS, CONVENTIONAL	20.00	EA	\$621.64	\$12,432.80
<b>Subcomponent Total</b>					<b>\$239,537.00</b>
<b>Lighting Component Total</b>					<b>\$239,537.00</b>

**LANDSCAPING COMPONENT**

**User Input Data**

<b>Description</b>	<b>Value</b>
Cost %	2.00
Component Detail	N
<b>Landscaping Component Total</b>	<b>\$56,761.47</b>

**BRIDGES COMPONENT**

**Bridge R-A2**

<b>Description</b>	<b>Value</b>
Estimate Type	SF Estimate
Primary Estimate	YES
Length (LF)	2,429.00
Width (LF)	36.00
Type	High Level
Cost Factor	2.04
Structure No.	
Removal of Existing Structures area	0.00
Default Cost per SF	\$135.00
Factored Cost per SF	\$275.40
<b>Final Cost per SF</b>	<b>\$276.12</b>
<b>Basic Bridge Cost</b>	<b>\$24,082,077.60</b>
Description	SR 429 RAMP A3 BRIDGE. SB SR 429 C-D ROAD TO WB I-4 EXPRESS LANES.

**Bridge Pay Items**

<b>Pay item</b>	<b>Description</b>	<b>Quantity</b>	<b>Unit</b>	<b>Unit Price</b>	<b>Extended Amount</b>
400-2-10	CONC CLASS II, APPROACH SLABS	80.00	CY	\$588.22	\$47,057.60
415-1-9	REINF STEEL- APPROACH SLABS	14,000.00	LB	\$1.14	\$15,960.00

<b>Bridge R-A2 Total</b>	\$24,145,095.20
<b>Bridges Component Total</b>	\$24,145,095.20

---

**RETAINING WALLS COMPONENT**

**Retaining Wall 1**

Description	Value
Length	3,090.00
Begin height	17.50
End Height	17.50
Multiplier	2

**Pay Items**

Pay item	Description	Quantity Unit	Unit Price	Extended Amount
548-12	RET WALL SYSTEM, PERM, EX BARRIER	108,150.00 SF	\$36.17	\$3,911,785.50

<b>Retaining Walls Component Total</b>	\$3,911,785.50
--	----------------

---

<b>Sequence 14 Total</b>	\$34,599,091.30
--------------------------	-----------------

---



Sequence: 15NUR - New Construction, Undivided, Rural

Net Length: 0.190 MI  
1,003 LF

Description: SR 429 Ramp A2: 2-Lane Ramp. SB SR 429 C-D Road to WB I-4 General Use Lanes. Includes Shoulder Barrier, Retaining Wall, and Bridge R-A3\_1

**EARTHWORK COMPONENT**

**User Input Data**

Description	Value
Standard Clearing and Grubbing Limits L/R	50.00 / 94.00
Incidental Clearing and Grubbing Area	0.00
Alignment Number	1
Distance	0.190
Top of Structural Course For Begin Section	117.50
Top of Structural Course For End Section	117.50
Horizontal Elevation For Begin Section	100.00
Horizontal Elevation For End Section	100.00
Front Slope L/R	6 to 1 / 6 to 1
Outside Shoulder Cross Slope L/R	5.00 % / 6.00 %
Roadway Cross Slope L/R	2.00 % / 2.00 %

**Pay Items**

Pay item	Description	Quantity	Unit	Unit Price	Extended Amount
110-1-1	CLEARING & GRUBBING	3.32	AC	\$21,000.00	\$69,720.00
120-6	EMBANKMENT	88,885.38	CY	\$20.88	\$1,855,926.73
<b>Earthwork Component Total</b>					<b>\$1,925,646.73</b>

**ROADWAY COMPONENT**

**User Input Data**

Description	Value
Number of Lanes	2
Roadway Pavement Width L/R	12.00 / 12.00
Structural Spread Rate	440
Friction Course Spread Rate	165

**Pay Items**

Pay item	Description	Quantity	Unit	Unit Price	Extended Amount
160-4	TYPE B STABILIZATION	4,904.53	SY	\$11.66	\$57,186.82
285-712	OPTIONAL BASE,BASE GROUP 12	2,748.77	SY	\$73.16	\$201,100.01
334-1-53	SUPERPAVE ASPH CONC, TRAF C, PG76-22	588.54	TN	\$127.05	\$74,774.01
337-7-83	ASPH CONC FC,TRAFFIC C,FC-12.5,PG 76-22	220.70	TN	\$122.75	\$27,090.92

**Pavement Marking Subcomponent**

Description	Value
Include Thermo/Tape/Other	Y
Pavement Type	Asphalt
Solid Stripe No. of Paint Applications	1
Solid Stripe No. of Stripes	2
Skip Stripe No. of Paint Applications	1
Skip Stripe No. of Stripes	1

**Pay Items**

Pay item	Description	Quantity	Unit	Unit Price	Extended Amount
----------	-------------	----------	------	------------	-----------------

706-1-1	RAISED PAVMT MARK, TYPE B W/O FINAL SURF	26.00 EA	\$3.58	\$93.08
710-11-101	PAINTED PAVT MARK,STD,WHITE,SOLID,6"	0.38 GM	\$1,080.33	\$410.53
710-11-231	PAINTED PAVT MARK,STD,YELLOW,SKIP,6"	0.19 GM	\$487.22	\$92.57
711-15-201	THERMOPLASTIC, STD- OP,YELLOW, SOLID, 6"	0.38 GM	\$4,988.35	\$1,895.57
711-16-101	THERMOPLASTIC, STD-OTH, WHITE, SOLID, 6"	0.38 GM	\$3,986.79	\$1,514.98
711-16-231	THERMOPLASTIC, STD-OTH, YELLOW, SKIP, 6"	0.19 GM	\$1,339.37	\$254.48

**Peripherals Subcomponent**

Description	Value
Off Road Bike Path(s)	0
Off Road Bike Path Width L/R	0.00 / 0.00
Bike Path Structural Spread Rate	0
Noise Barrier Wall Length	0.00
Noise Barrier Wall Begin Height	0.00
Noise Barrier Wall End Height	0.00

**Pay Items**

Pay item	Description	Quantity Unit	Unit Price	Extended Amount
521-72-40	SHLDR CONC BARRIER,38" OR 44" HEIGHT	2,125.00 LF	\$306.25	\$650,781.25
<b>Roadway Component Total</b>				<b>\$1,015,194.23</b>

**SHOULDER COMPONENT**

**User Input Data**

Description	Value
Total Outside Shoulder Width L/R	10.00 / 10.00
Total Outside Shoulder Perf. Turf Width L/R	0.00 / 0.00
Paved Outside Shoulder Width L/R	10.00 / 10.00
Structural Spread Rate	220
Friction Course Spread Rate	165
Total Width (T) / 8" Overlap (O)	T
Rumble Strips i; ½No. of Sides	2

**Pay Items**

Pay item	Description	Quantity Unit	Unit Price	Extended Amount
285-705	OPTIONAL BASE,BASE GROUP 05	2,302.90 SY	\$40.53	\$93,336.54
334-1-53	SUPERPAVE ASPH CONC, TRAF C, PG76-22	245.23 TN	\$127.05	\$31,156.47
337-7-83	ASPH CONC FC,TRAFFIC C,FC- 12.5,PG 76-22	183.92 TN	\$122.75	\$22,576.18
546-72-1	GROUND-IN RUMBLE STRIPS, 16"	0.38 GM	\$881.71	\$335.05

**X-Items**

Pay item	Description	Quantity Unit	Unit Price	Extended Amount
521-8-7	CONC BARRIER, W/JUNCT SL, 36 SS	800.00 LF	\$303.07	\$242,456.00

**Erosion Control**

**Pay Items**

Pay item	Description	Quantity Unit	Unit Price	Extended Amount
----------	-------------	---------------	------------	-----------------

104-10-3	SEDIMENT BARRIER	2,608.32 LF	\$1.20	\$3,129.98
104-11	FLOATING TURBIDITY BARRIER	47.50 LF	\$9.49	\$450.78
104-12	STAKED TURBIDITY BARRIER- NYL REINF PVC	47.50 LF	\$4.44	\$210.90
104-15	SOIL TRACKING PREVENTION DEVICE	1.00 EA	\$2,988.11	\$2,988.11
107-1	LITTER REMOVAL	2.30 AC	\$20.76	\$47.75
107-2	MOWING	2.30 AC	\$46.89	\$107.85
<b>Shoulder Component Total</b>				<b>\$396,795.61</b>

#### DRAINAGE COMPONENT

Pay Items				
Pay item	Description	Quantity Unit	Unit Price	Extended Amount
430-174-124	PIPE CULV, OPT MATL, ROUND,24"SD	152.00 LF	\$126.21	\$19,183.92
430-175-136	PIPE CULV, OPT MATL, ROUND, 36"S/CD	32.00 LF	\$342.26	\$10,952.32
430-984-129	MITERED END SECT, OPTIONAL RD, 24" SD	8.00 EA	\$2,253.96	\$18,031.68
570-1-1	PERFORMANCE TURF	133.76 SY	\$3.19	\$426.69
<b>Drainage Component Total</b>				<b>\$48,594.61</b>

#### SIGNING COMPONENT

Pay Items				
Pay item	Description	Quantity Unit	Unit Price	Extended Amount
700-1-11	SINGLE POST SIGN, F&I GM, <12 SF	1.00 AS	\$380.22	\$380.22
700-1-12	SINGLE POST SIGN, F&I GM, 12- 20 SF	4.00 AS	\$1,503.18	\$6,012.72
700-2-14	MULTI- POST SIGN, F&I GM, 31-50 SF	1.00 AS	\$5,637.01	\$5,637.01
<b>Signing Component Total</b>				<b>\$12,029.95</b>

#### INTELLIGENT TRAFFIC SYSTEM (ITS) COMPONENT

##### Description of Work

General ITS per LF of roadway.

##### EX-Items

Pay item	Description	Quantity Unit	Unit Price	Extended Amount
000-000	GENERAL ITS	1,962.00 LF	\$70.00	\$137,340.00
<b>Comment:</b> General ITS per LF of roadway.				
<b>Intelligent Traffic System (ITS) Component Total</b>				<b>\$137,340.00</b>

#### LIGHTING COMPONENT

##### Rural Lighting Subcomponent

##### Description

Multiplier (Number of Poles)

##### Pay Items

Value

9

Pay item	Description	Quantity	Unit	Unit Price	Extended Amount
630-2-11	CONDUIT, F& I, OPEN TRENCH	1,800.00	LF	\$9.76	\$17,568.00
635-2-11	PULL & SPLICE BOX, F&I, 13" x 24"	9.00	EA	\$767.98	\$6,911.82
715-1-13	LIGHTING CONDUCTORS, F&I, INSUL, NO.4-2	5,400.00	LF	\$2.62	\$14,148.00
715-4-14	LIGHT POLE COMPLETE, F&I-STD, 45'	9.00	EA	\$7,063.23	\$63,569.07
715-500-1	POLE CABLE DIST SYS, CONVENTIONAL	9.00	EA	\$621.64	\$5,594.76
<b>Subcomponent Total</b>					\$107,791.65
<b>Lighting Component Total</b>					\$107,791.65

### LANDSCAPING COMPONENT

#### User Input Data

Description	Value
Cost %	2.00
Component Detail	N

**Landscaping Component Total** \$29,211.69

### BRIDGES COMPONENT

#### Bridge R-A2\_1

Description	Value
Estimate Type	SF Estimate
Primary Estimate	YES
Length (LF)	1,373.00
Width (LF)	47.00
Type	High Level
Cost Factor	2.04
Structure No.	
Removal of Existing Structures area	0.00
Default Cost per SF	\$135.00
Factored Cost per SF	\$275.40
<b>Final Cost per SF</b>	<b>\$276.67</b>
<b>Basic Bridge Cost</b>	<b>\$17,771,837.40</b>

Description SR 429 SOUTHBOUND CONNECT I-4 WESTBOUND GUL (2-LANE RAMP BRIDGE)

#### Bridge Pay Items

Pay item	Description	Quantity	Unit	Unit Price	Extended Amount
400-2-10	CONC CLASS II, APPROACH SLABS	104.44	CY	\$588.22	\$61,433.70
415-1-9	REINF STEEL- APPROACH SLABS	18,277.00	LB	\$1.14	\$20,835.78
<b>Bridge R-A2_1 Total</b>					\$17,854,106.88
<b>Bridges Component Total</b>					\$17,854,106.88

### RETAINING WALLS COMPONENT

#### Retaining Wall 1

Description	Value
-------------	-------

Length	860.00
Begin height	17.50
End Height	17.50
Multiplier	2

**Pay Items**

<b>Pay item</b>	<b>Description</b>	<b>Quantity</b>	<b>Unit</b>	<b>Unit Price</b>	<b>Extended Amount</b>
548-12	RET WALL SYSTEM, PERM, EX BARRIER	30,100.00	SF	\$36.17	\$1,088,717.00
<b>Retaining Walls Component Total</b>					<b>\$1,088,717.00</b>

---

<b>Sequence 15 Total</b>	<b>\$22,615,428.35</b>
--------------------------	------------------------

---

Sequence: 16 NUR - New Construction, Undivided, Rural

Net Length: 0.360 MI  
1,901 LF

Description: SR 429 Ramp A2: 3-Lane Ramp. SB SR 429 C-D Road to WB I-4 General Use Lanes. Includes Bridge R-A3\_2

**EARTHWORK COMPONENT**

**User Input Data**

Description	Value
Standard Clearing and Grubbing Limits L/R	50.00 / 94.00
Incidental Clearing and Grubbing Area	0.00
Alignment Number	1
Distance	0.360
Top of Structural Course For Begin Section	117.50
Top of Structural Course For End Section	117.50
Horizontal Elevation For Begin Section	100.00
Horizontal Elevation For End Section	100.00
Front Slope L/R	6 to 1 / 6 to 1
Outside Shoulder Cross Slope L/R	5.00 % / 6.00 %
Roadway Cross Slope L/R	2.00 % / 2.00 %

**Pay Items**

Pay item	Description	Quantity	Unit	Unit Price	Extended Amount
110-1-1	CLEARING & GRUBBING	6.28	AC	\$21,000.00	\$131,880.00
120-6	EMBANKMENT	181,516.54	CY	\$20.88	\$3,790,065.36
<b>Earthwork Component Total</b>					<b>\$3,921,945.36</b>

**ROADWAY COMPONENT**

**User Input Data**

Description	Value
Number of Lanes	3
Roadway Pavement Width L/R	24.00 / 12.00
Structural Spread Rate	440
Friction Course Spread Rate	165

**Pay Items**

Pay item	Description	Quantity	Unit	Unit Price	Extended Amount
160-4	TYPE B STABILIZATION	12,249.60	SY	\$11.66	\$142,830.34
285-712	OPTIONAL BASE,BASE GROUP 12	7,742.59	SY	\$73.16	\$566,447.88
334-1-53	SUPERPAVE ASPH CONC, TRAF C, PG76-22	1,672.70	TN	\$127.05	\$212,516.54
337-7-83	ASPH CONC FC,TRAFFIC C,FC-12.5,PG 76-22	627.26	TN	\$122.75	\$76,996.16

**Pavement Marking Subcomponent**

Description	Value
Include Thermo/Tape/Other	Y
Pavement Type	Asphalt
Solid Stripe No. of Paint Applications	1
Solid Stripe No. of Stripes	2
Skip Stripe No. of Paint Applications	1
Skip Stripe No. of Stripes	2

**Pay Items**

Pay item	Description	Quantity	Unit	Unit Price	Extended Amount
----------	-------------	----------	------	------------	-----------------



706-1-1	RAISED PAVMT MARK, TYPE B W/O FINAL SURF	194.00 EA	\$3.58	\$694.52
710-11-101	PAINTED PAVT MARK,STD,WHITE,SOLID,6"	0.72 GM	\$1,080.33	\$777.84
710-11-231	PAINTED PAVT MARK,STD,YELLOW,SKIP,6"	0.72 GM	\$487.22	\$350.80
711-15-201	THERMOPLASTIC, STD- OP,YELLOW, SOLID, 6"	0.72 GM	\$4,988.35	\$3,591.61
711-16-101	THERMOPLASTIC, STD-OTH, WHITE, SOLID, 6"	0.72 GM	\$3,986.79	\$2,870.49
711-16-231	THERMOPLASTIC, STD-OTH, YELLOW, SKIP, 6"	0.72 GM	\$1,339.37	\$964.35

**Peripherals Subcomponent**

Description	Value
Off Road Bike Path(s)	0
Off Road Bike Path Width L/R	0.00 / 0.00
Bike Path Structural Spread Rate	0
Noise Barrier Wall Length	0.00
Noise Barrier Wall Begin Height	0.00
Noise Barrier Wall End Height	0.00

**Roadway Component Total**

\$1,008,040.54

**SHOULDER COMPONENT**

**User Input Data**

Description	Value
Total Outside Shoulder Width L/R	10.00 / 12.00
Total Outside Shoulder Perf. Turf Width L/R	0.00 / 2.00
Paved Outside Shoulder Width L/R	10.00 / 10.00
Structural Spread Rate	220
Friction Course Spread Rate	165
Total Width (T) / 8" Overlap (O)	T
Rumble Strips $i_c$ 1/2 No. of Sides	2

**Pay Items**

Pay item	Description	Quantity Unit	Unit Price	Extended Amount
285-705	OPTIONAL BASE,BASE GROUP 05	4,363.39 SY	\$40.53	\$176,848.20
334-1-53	SUPERPAVE ASPH CONC, TRAF C, PG76-22	464.64 TN	\$127.05	\$59,032.51
337-7-83	ASPH CONC FC,TRAFFIC C,FC- 12.5,PG 76-22	348.48 TN	\$122.75	\$42,775.92
546-72-1	GROUND-IN RUMBLE STRIPS, 16"	0.72 GM	\$881.71	\$634.83
570-1-1	PERFORMANCE TURF	422.40 SY	\$3.19	\$1,347.46

**Erosion Control**

**Pay Items**

Pay item	Description	Quantity Unit	Unit Price	Extended Amount
104-10-3	SEDIMENT BARRIER	4,942.08 LF	\$1.20	\$5,930.50
104-11	FLOATING TURBIDITY BARRIER	90.00 LF	\$9.49	\$854.10
104-12	STAKED TURBIDITY BARRIER- NYL REINF PVC	90.00 LF	\$4.44	\$399.60
104-15	SOIL TRACKING PREVENTION DEVICE	1.00 EA	\$2,988.11	\$2,988.11
107-1	LITTER REMOVAL	4.36 AC	\$20.76	\$90.51
107-2	MOWING	4.36 AC	\$46.89	\$204.44

Shoulder Component Total

\$291,106.18

**DRAINAGE COMPONENT**

**Pay Items**

Pay item	Description	Quantity Unit	Unit Price	Extended Amount
430-174-124	PIPE CULV, OPT MATL, ROUND,24"SD	288.00 LF	\$126.21	\$36,348.48
430-175-136	PIPE CULV, OPT MATL, ROUND, 36"S/CD	64.00 LF	\$342.26	\$21,904.64
430-984-129	MITERED END SECT, OPTIONAL RD, 24" SD	15.00 EA	\$2,253.96	\$33,809.40
570-1-1	PERFORMANCE TURF	253.44 SY	\$3.19	\$808.47
<b>Drainage Component Total</b>				<b>\$92,870.99</b>

**SIGNING COMPONENT**

**Pay Items**

Pay item	Description	Quantity Unit	Unit Price	Extended Amount
700-1-11	SINGLE POST SIGN, F&I GM, <12 SF	1.00 AS	\$380.22	\$380.22
700-1-12	SINGLE POST SIGN, F&I GM, 12-20 SF	8.00 AS	\$1,503.18	\$12,025.44
700-2-14	MULTI- POST SIGN, F&I GM, 31-50 SF	1.00 AS	\$5,637.01	\$5,637.01
<b>Signing Component Total</b>				<b>\$18,042.67</b>

**INTELLIGENT TRAFFIC SYSTEM (ITS) COMPONENT**

**Description of Work**

General ITS per LF of roadway.

**EX-Items**

Pay item	Description	Quantity Unit	Unit Price	Extended Amount
000-000	GENERAL ITS	4,338.00 LF	\$70.00	\$303,660.00
<b>Comment:</b> General ITS per LF of roadway.				
<b>Intelligent Traffic System (ITS) Component Total</b>				<b>\$303,660.00</b>

**LIGHTING COMPONENT**

**Rural Lighting Subcomponent**

**Description**

Multiplier (Number of Poles)

**Value**

38

**Pay Items**

Pay item	Description	Quantity Unit	Unit Price	Extended Amount
630-2-11	CONDUIT, F& I, OPEN TRENCH	7,600.00 LF	\$9.76	\$74,176.00
635-2-11	PULL & SPLICE BOX, F&I, 13" x 24"	38.00 EA	\$767.98	\$29,183.24
715-1-13	LIGHTING CONDUCTORS, F&I, INSUL, NO.4-2	22,800.00 LF	\$2.62	\$59,736.00
715-4-14	LIGHT POLE COMPLETE, F&I-STD, 45'	38.00 EA	\$7,063.23	\$268,402.74
715-500-1	POLE CABLE DIST SYS, CONVENTIONAL	38.00 EA	\$621.64	\$23,622.32

Subcomponent Total \$455,120.30

Lighting Component Total \$455,120.30

---

**LANDSCAPING COMPONENT**

**User Input Data**

Description	Value
Cost %	2.00
Component Detail	N

Landscaping Component Total \$27,840.35

---

**BRIDGES COMPONENT**

**Bridge R-A2\_2**

Description	Value
Estimate Type	SF Estimate
Primary Estimate	YES
Length (LF)	370.00
Width (LF)	59.00
Type	High Level
Cost Factor	2.04
Structure No.	
Removal of Existing Structures area	0.00
Default Cost per SF	\$135.00
Factored Cost per SF	\$275.40
<b>Final Cost per SF</b>	<b>\$280.13</b>
<b>Basic Bridge Cost</b>	<b>\$6,011,982.00</b>

Description SR 429 SOUTHBOUND CONNECT I-4 WESTBOUND GUL (3-LANE RAMP BRIDGE)

**Bridge Pay Items**

Pay item	Description	Quantity	Unit	Unit Price	Extended Amount
400-2-10	CONC CLASS II, APPROACH SLABS	131.11	CY	\$588.22	\$77,121.52
415-1-9	REINF STEEL- APPROACH SLABS	22,944.25	LB	\$1.14	\$26,156.44

**Bridge R-A2\_2 Total** \$6,115,259.97

**Bridges Component Total** \$6,115,259.97

---

**RETAINING WALLS COMPONENT**

**Retaining Wall 1**

Description	Value
Length	100.00
Begin height	25.00
End Height	25.00
Multiplier	1

**Pay Items**

Pay item	Description	Quantity	Unit	Unit Price	Extended Amount
548-12	RET WALL SYSTEM, PERM, EX BARRIER	2,500.00	SF	\$36.17	\$90,425.00

**Retaining Walls Component Total**

**\$90,425.00**

---

**Sequence 16 Total**

**\$12,324,311.36**

---

Sequence: 17 NUR - New Construction, Undivided, Rural

Net Length: 0.420 MI  
2,218 LF

Description: SR 429 Ramp B1: 1-Lane Ramp. EB I-4 Express Lanes to NB SR 429 C-D Road. Includes  
Shoulder Barrier, Retaining Wall, Bridge R-B1.

**EARTHWORK COMPONENT**

**User Input Data**

Description	Value
Standard Clearing and Grubbing Limits L/R	50.00 / 50.00
Incidental Clearing and Grubbing Area	0.00
Alignment Number	1
Distance	0.420
Top of Structural Course For Begin Section	117.50
Top of Structural Course For End Section	117.50
Horizontal Elevation For Begin Section	100.00
Horizontal Elevation For End Section	100.00
Front Slope L/R	6 to 1 / 6 to 1
Outside Shoulder Cross Slope L/R	5.00 % / 6.00 %
Roadway Cross Slope L/R	2.00 % / 2.00 %

**Pay Items**

Pay item	Description	Quantity	Unit	Unit Price	Extended Amount
110-1-1	CLEARING & GRUBBING	5.09	AC	\$21,000.00	\$106,890.00
120-6	EMBANKMENT	101,216.19	CY	\$20.88	\$2,113,394.05
<b>Earthwork Component Total</b>					<b>\$2,220,284.05</b>

**ROADWAY COMPONENT**

**User Input Data**

Description	Value
Number of Lanes	1
Roadway Pavement Width L/R	0.00 / 15.00
Structural Spread Rate	440
Friction Course Spread Rate	165

**Pay Items**

Pay item	Description	Quantity	Unit	Unit Price	Extended Amount
160-4	TYPE B STABILIZATION	7,638.40	SY	\$11.66	\$89,063.74
285-712	OPTIONAL BASE,BASE GROUP 12	3,777.31	SY	\$73.16	\$276,348.00
334-1-53	SUPERPAVE ASPH CONC, TRAF C, PG76-22	813.12	TN	\$127.05	\$103,306.90
337-7-83	ASPH CONC FC,TRAFFIC C,FC-12.5,PG 76-22	304.92	TN	\$122.75	\$37,428.93

**Pavement Marking Subcomponent**

Description	Value
Include Thermo/Tape/Other	Y
Pavement Type	Asphalt
Solid Stripe No. of Paint Applications	1
Solid Stripe No. of Stripes	2
Skip Stripe No. of Paint Applications	1
Skip Stripe No. of Stripes	0

**Pay Items**

Pay item	Description	Quantity	Unit	Unit Price	Extended Amount
----------	-------------	----------	------	------------	-----------------

710-11-101	PAINTED PAVT MARK,STD,WHITE,SOLID,6"	0.84 GM	\$1,080.33	\$907.48
711-15-201	THERMOPLASTIC, STD- OP,YELLOW, SOLID, 6"	0.84 GM	\$4,988.35	\$4,190.21
711-16-101	THERMOPLASTIC, STD-OTH, WHITE, SOLID, 6"	0.84 GM	\$3,986.79	\$3,348.90

#### Peripherals Subcomponent

Description	Value
Off Road Bike Path(s)	0
Off Road Bike Path Width L/R	0.00 / 0.00
Bike Path Structural Spread Rate	0
Noise Barrier Wall Length	0.00
Noise Barrier Wall Begin Height	0.00
Noise Barrier Wall End Height	0.00

#### Pay Items

Pay item	Description	Quantity Unit	Unit Price	Extended Amount
521-72-40	SHLDR CONC BARRIER,38" OR 44" HEIGHT	687.00 LF	\$306.25	\$210,393.75
<b>Roadway Component Total</b>				<b>\$724,987.91</b>

### SHOULDER COMPONENT

#### User Input Data

Description	Value
Total Outside Shoulder Width L/R	6.00 / 10.00
Total Outside Shoulder Perf. Turf Width L/R	0.00 / 0.00
Paved Outside Shoulder Width L/R	6.00 / 10.00
Structural Spread Rate	220
Friction Course Spread Rate	165
Total Width (T) / 8" Overlap (O)	T
Rumble Strips i; ½No. of Sides	2

#### Pay Items

Pay item	Description	Quantity Unit	Unit Price	Extended Amount
285-705	OPTIONAL BASE,BASE GROUP 05	4,105.02 SY	\$40.53	\$166,376.46
334-1-53	SUPERPAVE ASPH CONC, TRAF C, PG76-22	433.66 TN	\$127.05	\$55,096.50
337-7-83	ASPH CONC FC,TRAFFIC C,FC- 12.5,PG 76-22	325.25 TN	\$122.75	\$39,924.44
546-72-1	GROUND-IN RUMBLE STRIPS, 16"	0.84 GM	\$881.71	\$740.64

#### X-Items

Pay item	Description	Quantity Unit	Unit Price	Extended Amount
521-8-7	CONC BARRIER, W/JUNCT SL, 36 SS	2,000.00 LF	\$303.07	\$606,140.00

#### Erosion Control

#### Pay Items

Pay item	Description	Quantity Unit	Unit Price	Extended Amount
104-10-3	SEDIMENT BARRIER	5,765.76 LF	\$1.20	\$6,918.91
104-11	FLOATING TURBIDITY BARRIER	105.00 LF	\$9.49	\$996.45
104-12	STAKED TURBIDITY BARRIER- NYL REINF PVC	105.00 LF	\$4.44	\$466.20



104-15	SOIL TRACKING PREVENTION DEVICE	1.00 EA	\$2,988.11	\$2,988.11
107-1	LITTER REMOVAL	5.09 AC	\$20.76	\$105.67
107-2	MOWING	5.09 AC	\$46.89	\$238.67
<b>Shoulder Component Total</b>				<b>\$879,992.05</b>

**DRAINAGE COMPONENT**

**Pay Items**

Pay item	Description	Quantity Unit	Unit Price	Extended Amount
430-174-124	PIPE CULV, OPT MATL, ROUND,24"SD	336.00 LF	\$126.21	\$42,406.56
430-175-136	PIPE CULV, OPT MATL, ROUND, 36"S/CD	72.00 LF	\$342.26	\$24,642.72
430-984-129	MITERED END SECT, OPTIONAL RD, 24" SD	17.00 EA	\$2,253.96	\$38,317.32
570-1-1	PERFORMANCE TURF	295.68 SY	\$3.19	\$943.22
<b>Drainage Component Total</b>				<b>\$106,309.82</b>

**SIGNING COMPONENT**

**Pay Items**

Pay item	Description	Quantity Unit	Unit Price	Extended Amount
700-1-11	SINGLE POST SIGN, F&I GM, <12 SF	1.00 AS	\$380.22	\$380.22
700-1-12	SINGLE POST SIGN, F&I GM, 12- 20 SF	9.00 AS	\$1,503.18	\$13,528.62
700-2-14	MULTI- POST SIGN, F&I GM, 31-50 SF	1.00 AS	\$5,637.01	\$5,637.01
<b>Signing Component Total</b>				<b>\$19,545.85</b>

**INTELLIGENT TRAFFIC SYSTEM (ITS) COMPONENT**

**Description of Work**

General ITS per LF of roadway.

**EX-Items**

Pay item	Description	Quantity Unit	Unit Price	Extended Amount
000-000	GENERAL ITS	2,805.00 LF	\$70.00	\$196,350.00
<b>Comment:</b> General ITS per LF of roadway.				
<b>Intelligent Traffic System (ITS) Component Total</b>				<b>\$196,350.00</b>

**LIGHTING COMPONENT**

**Rural Lighting Subcomponent**

Description	Value
Multiplier (Number of Poles)	15

**Pay Items**

Pay item	Description	Quantity Unit	Unit Price	Extended Amount
630-2-11	CONDUIT, F& I, OPEN TRENCH	3,000.00 LF	\$9.76	\$29,280.00
635-2-11	PULL & SPLICE BOX, F&I, 13" x 24"	15.00 EA	\$767.98	\$11,519.70

715-1-13	LIGHTING CONDUCTORS, F&I, INSUL, NO.4-2	9,000.00 LF	\$2.62	\$23,580.00
715-4-14	LIGHT POLE COMPLETE, F&I- STD, 45'	15.00 EA	\$7,063.23	\$105,948.45
715-500-1	POLE CABLE DIST SYS, CONVENTIONAL	15.00 EA	\$621.64	\$9,324.60
	<b>Subcomponent Total</b>			\$179,652.75
	<b>Lighting Component Total</b>			\$179,652.75

### LANDSCAPING COMPONENT

#### User Input Data

Description	Value
Cost %	2.00
Component Detail	N

**Landscaping Component Total** \$34,225.80

### BRIDGES COMPONENT

#### Bridge R-B1

Description	Value
Estimate Type	SF Estimate
Primary Estimate	YES
Length (LF)	950.00
Width (LF)	34.00
Type	High Level
Cost Factor	2.04
Structure No.	
Removal of Existing Structures area	0.00
Default Cost per SF	\$135.00
Factored Cost per SF	\$275.40
<b>Final Cost per SF</b>	<b>\$277.24</b>
<b>Basic Bridge Cost</b>	<b>\$8,895,420.00</b>

Description SR 429 RAMP B1 BRIDGE: 1-LANE RAMP BRIDGE. EB I-4 EXPRESS LANES TO NB SR 429 C-D ROAD.

#### Bridge Pay Items

Pay item	Description	Quantity	Unit	Unit Price	Extended Amount
400-2-10	CONC CLASS II, APPROACH SLABS	75.56	CY	\$588.22	\$44,445.90
415-1-9	REINF STEEL- APPROACH SLABS	13,223.00	LB	\$1.14	\$15,074.22
	<b>Bridge R-B1 Total</b>				\$8,954,940.12
	<b>Bridges Component Total</b>				\$8,954,940.12

### RETAINING WALLS COMPONENT

#### Retaining Wall 1

Description	Value
Length	2,060.00
Begin height	17.50
End Height	17.50
Multiplier	2

**Pay Items**

<b>Pay item</b>	<b>Description</b>	<b>Quantity</b>	<b>Unit</b>	<b>Unit Price</b>	<b>Extended Amount</b>
548-12	RET WALL SYSTEM, PERM, EX BARRIER	72,100.00	SF	\$36.17	\$2,607,857.00
<b>Retaining Walls Component Total</b>					<b>\$2,607,857.00</b>

---

**Sequence 17 Total** **\$15,924,145.35**

---

Sequence: 18 NUR - New Construction, Undivided, Rural

Net Length: 0.430 MI  
2,270 LF

Description: SR 429 Ramp B2: 2-Lane Ramp. EB I-4 General Use Lanes to NB SR 429 C-D Road. Includes Shoulder Barrier, Noise Wall, Retaining Wall.

**EARTHWORK COMPONENT**

**User Input Data**

Description	Value
Standard Clearing and Grubbing Limits L/R	50.00 / 94.00
Incidental Clearing and Grubbing Area	0.00
Alignment Number	1
Distance	0.430
Top of Structural Course For Begin Section	117.50
Top of Structural Course For End Section	117.50
Horizontal Elevation For Begin Section	100.00
Horizontal Elevation For End Section	100.00
Front Slope L/R	1 to 1 / 1 to 1
Outside Shoulder Cross Slope L/R	5.00 % / 6.00 %
Roadway Cross Slope L/R	2.00 % / 2.00 %

**Pay Items**

Pay item	Description	Quantity	Unit	Unit Price	Extended Amount
110-1-1	CLEARING & GRUBBING	7.51	AC	\$21,000.00	\$157,710.00
120-6	EMBANKMENT	81,161.75	CY	\$20.88	\$1,694,657.34
<b>Earthwork Component Total</b>					<b>\$1,852,367.34</b>

**ROADWAY COMPONENT**

**User Input Data**

Description	Value
Number of Lanes	2
Roadway Pavement Width L/R	12.00 / 12.00
Structural Spread Rate	440
Friction Course Spread Rate	165

**Pay Items**

Pay item	Description	Quantity	Unit	Unit Price	Extended Amount
160-4	TYPE B STABILIZATION	10,595.20	SY	\$11.66	\$123,540.03
285-712	OPTIONAL BASE,BASE GROUP 12	6,220.90	SY	\$73.16	\$455,121.04
334-1-53	SUPERPAVE ASPH CONC, TRAF C, PG76-22	1,331.97	TN	\$127.05	\$169,226.79
337-7-83	ASPH CONC FC,TRAFFIC C,FC-12.5,PG 76-22	499.49	TN	\$122.75	\$61,312.40

**Pavement Marking Subcomponent**

Description	Value
Include Thermo/Tape/Other	Y
Pavement Type	Asphalt
Solid Stripe No. of Paint Applications	1
Solid Stripe No. of Stripes	2
Skip Stripe No. of Paint Applications	1
Skip Stripe No. of Stripes	1

**Pay Items**

Pay item	Description	Quantity	Unit	Unit Price	Extended Amount
----------	-------------	----------	------	------------	-----------------

706-1-1	RAISED PAVMT MARK, TYPE B W/O FINAL SURF	58.00 EA	\$3.58	\$207.64
710-11-101	PAINTED PAVT MARK,STD,WHITE,SOLID,6"	0.86 GM	\$1,080.33	\$929.08
710-11-231	PAINTED PAVT MARK,STD,YELLOW,SKIP,6"	0.43 GM	\$487.22	\$209.50
711-15-201	THERMOPLASTIC, STD- OP,YELLOW, SOLID, 6"	0.86 GM	\$4,988.35	\$4,289.98
711-16-101	THERMOPLASTIC, STD-OTH, WHITE, SOLID, 6"	0.86 GM	\$3,986.79	\$3,428.64
711-16-231	THERMOPLASTIC, STD-OTH, YELLOW, SKIP, 6"	0.43 GM	\$1,339.37	\$575.93

#### Peripherals Subcomponent

Description	Value
Off Road Bike Path(s)	0
Off Road Bike Path Width L/R	0.00 / 0.00
Bike Path Structural Spread Rate	0
Noise Barrier Wall Length	2,232.00
Noise Barrier Wall Begin Height	20.00
Noise Barrier Wall End Height	20.00

#### Pay Items

Pay item	Description	Quantity	Unit	Unit Price	Extended Amount
339-1	MISCELLANEOUS ASPHALT PAVEMENT	61.47	TN	\$252.78	\$15,538.39
521-72-40	SHLDR CONC BARRIER,38" OR 44" HEIGHT	3,476.00	LF	\$306.25	\$1,064,525.00
534-72-101	SOUND/NOISE BARRIER-INC FOUNDATION, PERM	44,640.00	SF	\$40.65	\$1,814,616.00
536-1-1	GUARDRAIL- ROADWAY, GEN TL-3	1,844.00	LF	\$20.52	\$37,838.88
<b>Roadway Component Total</b>					<b>\$3,751,359.30</b>

### SHOULDER COMPONENT

#### User Input Data

Description	Value
Total Outside Shoulder Width L/R	8.00 / 10.00
Total Outside Shoulder Perf. Turf Width L/R	0.00 / 0.00
Paved Outside Shoulder Width L/R	8.00 / 10.00
Structural Spread Rate	220
Friction Course Spread Rate	165
Total Width (T) / 8" Overlap (O)	T
Rumble Strips i <sub>l</sub> ½No. of Sides	2

#### Pay Items

Pay item	Description	Quantity	Unit	Unit Price	Extended Amount
285-705	OPTIONAL BASE,BASE GROUP 05	4,707.30	SY	\$40.53	\$190,786.87
334-1-53	SUPERPAVE ASPH CONC, TRAF C, PG76-22	499.49	TN	\$127.05	\$63,460.20
337-7-83	ASPH CONC FC,TRAFFIC C,FC- 12.5,PG 76-22	374.62	TN	\$122.75	\$45,984.60
546-72-1	GROUND-IN RUMBLE STRIPS, 16"	0.86	GM	\$881.71	\$758.27

#### X-Items

Pay item	Description	Quantity	Unit	Unit Price	Extended Amount
----------	-------------	----------	------	------------	-----------------

521-8-7	CONC BARRIER, W/JUNCT SL, 36 SS	600.00 LF	\$303.07	\$181,842.00
---------	------------------------------------	-----------	----------	--------------

**Erosion Control**

**Pay Items**

Pay item	Description	Quantity Unit	Unit Price	Extended Amount
104-10-3	SEDIMENT BARRIER	5,903.04 LF	\$1.20	\$7,083.65
104-11	FLOATING TURBIDITY BARRIER	107.50 LF	\$9.49	\$1,020.18
104-12	STAKED TURBIDITY BARRIER- NYL REINF PVC	107.50 LF	\$4.44	\$477.30
104-15	SOIL TRACKING PREVENTION DEVICE	1.00 EA	\$2,988.11	\$2,988.11
107-1	LITTER REMOVAL	5.21 AC	\$20.76	\$108.16
107-2	MOWING	5.21 AC	\$46.89	\$244.30
<b>Shoulder Component Total</b>				<b>\$494,753.65</b>

**DRAINAGE COMPONENT**

**Pay Items**

Pay item	Description	Quantity Unit	Unit Price	Extended Amount
430-174-124	PIPE CULV, OPT MATL, ROUND,24"SD	344.00 LF	\$126.21	\$43,416.24
430-175-136	PIPE CULV, OPT MATL, ROUND, 36"S/CD	80.00 LF	\$342.26	\$27,380.80
430-984-129	MITERED END SECT, OPTIONAL RD, 24" SD	18.00 EA	\$2,253.96	\$40,571.28
570-1-1	PERFORMANCE TURF	302.72 SY	\$3.19	\$965.68
<b>Drainage Component Total</b>				<b>\$112,334.00</b>

**SIGNING COMPONENT**

**Pay Items**

Pay item	Description	Quantity Unit	Unit Price	Extended Amount
700-1-11	SINGLE POST SIGN, F&I GM, <12 SF	1.00 AS	\$380.22	\$380.22
700-1-12	SINGLE POST SIGN, F&I GM, 12-20 SF	9.00 AS	\$1,503.18	\$13,528.62
700-2-14	MULTI- POST SIGN, F&I GM, 31-50 SF	1.00 AS	\$5,637.01	\$5,637.01
<b>Signing Component Total</b>				<b>\$19,545.85</b>

**INTELLIGENT TRAFFIC SYSTEM (ITS) COMPONENT**

**Description of Work**

General ITS per LF of roadway.

**EX-Items**

Pay item	Description	Quantity Unit	Unit Price	Extended Amount
000-000	GENERAL ITS	2,758.00 LF	\$70.00	\$193,060.00
<b>Comment:</b> General ITS per LF of roadway.				
<b>Intelligent Traffic System (ITS) Component Total</b>				<b>\$193,060.00</b>



**LIGHTING COMPONENT**

**Rural Lighting Subcomponent**

<b>Description</b>		<b>Value</b>			
Multiplier (Number of Poles)		15			
<b>Pay Items</b>					
<b>Pay item</b>	<b>Description</b>	<b>Quantity</b>	<b>Unit</b>	<b>Unit Price</b>	<b>Extended Amount</b>
630-2-11	CONDUIT, F& I, OPEN TRENCH	3,000.00	LF	\$9.76	\$29,280.00
635-2-11	PULL & SPLICE BOX, F&I, 13" x 24"	15.00	EA	\$767.98	\$11,519.70
715-1-13	LIGHTING CONDUCTORS, F&I, INSUL, NO.4-2	9,000.00	LF	\$2.62	\$23,580.00
715-4-14	LIGHT POLE COMPLETE, F&I-STD, 45'	15.00	EA	\$7,063.23	\$105,948.45
715-500-1	POLE CABLE DIST SYS, CONVENTIONAL	15.00	EA	\$621.64	\$9,324.60
<b>Subcomponent Total</b>					<b>\$179,652.75</b>
<b>Lighting Component Total</b>					<b>\$179,652.75</b>

---

**LANDSCAPING COMPONENT**

**User Input Data**

<b>Description</b>	<b>Value</b>
Cost %	2.00
Component Detail	N
<b>Landscaping Component Total</b>	<b>\$87,168.94</b>

---

**RETAINING WALLS COMPONENT**

**Retaining Wall 1**

<b>Description</b>	<b>Value</b>
Length	600.00
Begin height	17.50
End Height	17.50
Multiplier	2

**Pay Items**

<b>Pay item</b>	<b>Description</b>	<b>Quantity</b>	<b>Unit</b>	<b>Unit Price</b>	<b>Extended Amount</b>
548-12	RET WALL SYSTEM, PERM, EX BARRIER	21,000.00	SF	\$36.17	\$759,570.00
<b>Retaining Walls Component Total</b>					<b>\$759,570.00</b>

---

**Sequence 18 Total** **\$7,449,811.83**

---

Sequence: 19NUR - New Construction, Undivided, Rural

Net Length: 1.010 MI  
5,333 LF

Description: SR 429 Ramp B2: 3-Lane Ramp. EB I-4 General Use Lanes to NB SR 429 C-D Road. Noise Wall. Bridge.

**EARTHWORK COMPONENT**

**User Input Data**

Description	Value
Standard Clearing and Grubbing Limits L/R	50.00 / 94.00
Incidental Clearing and Grubbing Area	0.00
Alignment Number	1
Distance	1.010
Top of Structural Course For Begin Section	105.00
Top of Structural Course For End Section	105.00
Horizontal Elevation For Begin Section	100.00
Horizontal Elevation For End Section	100.00
Front Slope L/R	6 to 1 / 6 to 1
Outside Shoulder Cross Slope L/R	5.00 % / 6.00 %
Roadway Cross Slope L/R	2.00 % / 2.00 %

**Pay Items**

Pay item	Description	Quantity	Unit	Unit Price	Extended Amount
110-1-1	CLEARING & GRUBBING	17.63	AC	\$21,000.00	\$370,230.00
120-6	EMBANKMENT	62,624.85	CY	\$20.88	\$1,307,606.87
<b>Earthwork Component Total</b>					<b>\$1,677,836.87</b>

**ROADWAY COMPONENT**

**User Input Data**

Description	Value
Number of Lanes	3
Roadway Pavement Width L/R	12.00 / 24.00
Structural Spread Rate	440
Friction Course Spread Rate	165

**Pay Items**

Pay item	Description	Quantity	Unit	Unit Price	Extended Amount
160-4	TYPE B STABILIZATION	35,552.00	SY	\$11.66	\$414,536.32
285-712	OPTIONAL BASE,BASE GROUP 12	21,722.27	SY	\$73.16	\$1,589,201.27
334-1-53	SUPERPAVE ASPH CONC, TRAF C, PG76-22	4,692.86	TN	\$127.05	\$596,227.86
337-7-83	ASPH CONC FC,TRAFFIC C,FC-12.5,PG 76-22	1,759.82	TN	\$122.75	\$216,017.90

**Pavement Marking Subcomponent**

Description	Value
Include Thermo/Tape/Other	Y
Pavement Type	Asphalt
Solid Stripe No. of Paint Applications	1
Solid Stripe No. of Stripes	2
Skip Stripe No. of Paint Applications	1
Skip Stripe No. of Stripes	2

**Pay Items**

Pay item	Description	Quantity	Unit	Unit Price	Extended Amount
----------	-------------	----------	------	------------	-----------------

706-1-1	RAISED PAVMT MARK, TYPE B W/O FINAL SURF	545.00 EA	\$3.58	\$1,951.10
710-11-101	PAINTED PAVT MARK,STD,WHITE,SOLID,6"	2.02 GM	\$1,080.33	\$2,182.27
710-11-231	PAINTED PAVT MARK,STD,YELLOW,SKIP,6"	2.02 GM	\$487.22	\$984.18
711-15-201	THERMOPLASTIC, STD- OP,YELLOW, SOLID, 6"	2.02 GM	\$4,988.35	\$10,076.47
711-16-101	THERMOPLASTIC, STD-OTH, WHITE, SOLID, 6"	2.02 GM	\$3,986.79	\$8,053.32
711-16-231	THERMOPLASTIC, STD-OTH, YELLOW, SKIP, 6"	2.02 GM	\$1,339.37	\$2,705.53

**Peripherals Subcomponent**

Description	Value
Off Road Bike Path(s)	0
Off Road Bike Path Width L/R	0.00 / 0.00
Bike Path Structural Spread Rate	0
Noise Barrier Wall Length	4,440.00
Noise Barrier Wall Begin Height	20.00
Noise Barrier Wall End Height	20.00

**Pay Items**

Pay item	Description	Quantity Unit	Unit Price	Extended Amount
521-72-40	SHLDR CONC BARRIER,38" OR 44" HEIGHT	230.00 LF	\$306.25	\$70,437.50
534-72-101	SOUND/NOISE BARRIER-INC FOUNDATION, PERM	88,800.00 SF	\$40.65	\$3,609,720.00
<b>Roadway Component Total</b>				<b>\$6,522,093.73</b>

**SHOULDER COMPONENT**

**User Input Data**

Description	Value
Total Outside Shoulder Width L/R	12.00 / 12.00
Total Outside Shoulder Perf. Turf Width L/R	2.00 / 2.00
Paved Outside Shoulder Width L/R	10.00 / 10.00
Structural Spread Rate	220
Friction Course Spread Rate	165
Total Width (T) / 8" Overlap (O)	T
Rumble Strips i; ½No. of Sides	2

**Pay Items**

Pay item	Description	Quantity Unit	Unit Price	Extended Amount
285-705	OPTIONAL BASE,BASE GROUP 05	12,241.74 SY	\$40.53	\$496,157.72
334-1-53	SUPERPAVE ASPH CONC, TRAF C, PG76-22	1,303.57 TN	\$127.05	\$165,618.57
337-7-83	ASPH CONC FC,TRAFFIC C,FC- 12.5,PG 76-22	977.68 TN	\$122.75	\$120,010.22
546-72-1	GROUND-IN RUMBLE STRIPS, 16"	2.02 GM	\$881.71	\$1,781.05
570-1-1	PERFORMANCE TURF	2,370.13 SY	\$3.19	\$7,560.71

**X-Items**

Pay item	Description	Quantity Unit	Unit Price	Extended Amount
521-8-7	CONC BARRIER, W/JUNCT SL, 36 SS	691.00 LF	\$303.07	\$209,421.37

**Erosion Control****Pay Items**

Pay item	Description	Quantity Unit	Unit Price	Extended Amount
104-10-3	SEDIMENT BARRIER	13,865.28 LF	\$1.20	\$16,638.34
104-11	FLOATING TURBIDITY BARRIER	252.50 LF	\$9.49	\$2,396.22
104-12	STAKED TURBIDITY BARRIER- NYL REINF PVC	252.50 LF	\$4.44	\$1,121.10
104-15	SOIL TRACKING PREVENTION DEVICE	2.00 EA	\$2,988.11	\$5,976.22
107-1	LITTER REMOVAL	12.24 AC	\$20.76	\$254.10
107-2	MOWING	12.24 AC	\$46.89	\$573.93
<b>Shoulder Component Total</b>				<b>\$1,027,509.56</b>

**DRAINAGE COMPONENT****Pay Items**

Pay item	Description	Quantity Unit	Unit Price	Extended Amount
430-174-124	PIPE CULV, OPT MATL, ROUND,24"SD	808.00 LF	\$126.21	\$101,977.68
430-175-136	PIPE CULV, OPT MATL, ROUND, 36"S/CD	176.00 LF	\$342.26	\$60,237.76
430-984-129	MITERED END SECT, OPTIONAL RD, 24" SD	41.00 EA	\$2,253.96	\$92,412.36
570-1-1	PERFORMANCE TURF	711.04 SY	\$3.19	\$2,268.22
<b>Drainage Component Total</b>				<b>\$256,896.02</b>

**SIGNING COMPONENT****Pay Items**

Pay item	Description	Quantity Unit	Unit Price	Extended Amount
700-1-11	SINGLE POST SIGN, F&I GM, <12 SF	3.00 AS	\$380.22	\$1,140.66
700-1-12	SINGLE POST SIGN, F&I GM, 12- 20 SF	21.00 AS	\$1,503.18	\$31,566.78
700-2-14	MULTI- POST SIGN, F&I GM, 31-50 SF	3.00 AS	\$5,637.01	\$16,911.03
<b>Signing Component Total</b>				<b>\$49,618.47</b>

**INTELLIGENT TRAFFIC SYSTEM (ITS) COMPONENT****Description of Work**

General ITS per LF of roadway.

**EX-Items**

Pay item	Description	Quantity Unit	Unit Price	Extended Amount
000-000	GENERAL ITS	5,744.00 LF	\$70.00	\$402,080.00
<b>Comment:</b> General ITS per LF of roadway.				

**Intelligent Traffic System (ITS) Component Total** **\$402,080.00**

**LIGHTING COMPONENT****Rural Lighting Subcomponent**

<b>Description</b>				<b>Value</b>
Multiplier (Number of Poles)				61
<b>Pay Items</b>				
<b>Pay item</b>	<b>Description</b>	<b>Quantity</b>	<b>Unit</b>	<b>Unit Price</b>
630-2-11	CONDUIT, F& I, OPEN TRENCH	12,200.00	LF	\$9.76
635-2-11	PULL & SPLICE BOX, F&I, 13" x 24"	61.00	EA	\$767.98
715-1-13	LIGHTING CONDUCTORS, F&I, INSUL, NO.4-2	36,600.00	LF	\$2.62
715-4-14	LIGHT POLE COMPLETE, F&I-STD, 45'	61.00	EA	\$7,063.23
715-500-1	POLE CABLE DIST SYS, CONVENTIONAL	61.00	EA	\$621.64
	<b>Subcomponent Total</b>			<b>\$730,587.85</b>
	<b>Lighting Component Total</b>			<b>\$730,587.85</b>

**LANDSCAPING COMPONENT**

**User Input Data**

<b>Description</b>	<b>Value</b>
Cost %	2.00
Component Detail	N

**Landscaping Component Total** **\$156,129.99**

**BRIDGES COMPONENT**

**Bridge R-B2**

<b>Description</b>	<b>Value</b>
Estimate Type	SF Estimate
Primary Estimate	YES
Length (LF)	1,056.00
Width (LF)	63.00
Type	High Level
Cost Factor	2.04
Structure No.	
Removal of Existing Structures area	0.00
Default Cost per SF	\$135.00
Factored Cost per SF	\$275.40
<b>Final Cost per SF</b>	<b>\$277.06</b>
<b>Basic Bridge Cost</b>	<b>\$18,321,811.20</b>

Description SR 429 RAMP B2: 3-LANE RAMP BRIDGE. EB I-4 GENERAL USE LANES TO NB SR 429 C-D ROAD.

**Bridge Pay Items**

<b>Pay item</b>	<b>Description</b>	<b>Quantity</b>	<b>Unit</b>	<b>Unit Price</b>	<b>Extended Amount</b>
400-2-10	CONC CLASS II, APPROACH SLABS	140.00	CY	\$588.22	\$82,350.80
415-1-9	REINF STEEL- APPROACH SLABS	24,500.00	LB	\$1.14	\$27,930.00
	<b>Bridge R-B2 Total</b>				<b>\$18,432,092.00</b>
	<b>Bridges Component Total</b>				<b>\$18,432,092.00</b>

**RETAINING WALLS COMPONENT**

**Retaining Wall 1**

<b>Description</b>	<b>Value</b>
Length	812.00
Begin height	17.50
End Height	17.50
Multiplier	2

**Pay Items**

<b>Pay item</b>	<b>Description</b>	<b>Quantity</b>	<b>Unit</b>	<b>Unit Price</b>	<b>Extended Amount</b>
548-12	RET WALL SYSTEM, PERM, EX BARRIER	28,420.00	SF	\$36.17	\$1,027,951.40

**Retaining Walls Component Total** \$1,027,951.40

---

**Sequence 19 Total** \$30,282,795.89

---

Sequence: 20 NUR - New Construction, Undivided, Rural

Net Length: 0.240 MI  
1,267 LF

Description: SR 538 Ramp B3: 1-Lane Ramp. EB I-4 General Use Lanes to SB SR 538 Mainline. Includes Bridge R-B3

### EARTHWORK COMPONENT

#### User Input Data

Description	Value
Standard Clearing and Grubbing Limits L/R	50.00 / 50.00
Incidental Clearing and Grubbing Area	0.00
Alignment Number	1
Distance	0.240
Top of Structural Course For Begin Section	117.50
Top of Structural Course For End Section	117.50
Horizontal Elevation For Begin Section	100.00
Horizontal Elevation For End Section	100.00
Front Slope L/R	6 to 1 / 6 to 1
Outside Shoulder Cross Slope L/R	5.00 % / 6.00 %
Roadway Cross Slope L/R	2.00 % / 2.00 %

#### Pay Items

Pay item	Description	Quantity	Unit	Unit Price	Extended Amount
110-1-1	CLEARING & GRUBBING	2.91	AC	\$21,000.00	\$61,110.00
120-6	EMBANKMENT	59,253.33	CY	\$20.88	\$1,237,209.53
<b>Earthwork Component Total</b>					<b>\$1,298,319.53</b>

### ROADWAY COMPONENT

#### User Input Data

Description	Value
Number of Lanes	1
Roadway Pavement Width L/R	0.00 / 15.00
Structural Spread Rate	440
Friction Course Spread Rate	165

#### Pay Items

Pay item	Description	Quantity	Unit	Unit Price	Extended Amount
160-4	TYPE B STABILIZATION	4,787.20	SY	\$11.66	\$55,818.75
285-712	OPTIONAL BASE,BASE GROUP 12	2,158.46	SY	\$73.16	\$157,912.93
334-1-53	SUPERPAVE ASPH CONC, TRAF C, PG76-22	464.64	TN	\$127.05	\$59,032.51
337-7-83	ASPH CONC FC,TRAFFIC C,FC-12.5,PG 76-22	174.24	TN	\$122.75	\$21,387.96

#### Pavement Marking Subcomponent

Description	Value
Include Thermo/Tape/Other	Y
Pavement Type	Asphalt
Solid Stripe No. of Paint Applications	1
Solid Stripe No. of Stripes	2
Skip Stripe No. of Paint Applications	1
Skip Stripe No. of Stripes	0

#### Pay Items

Pay item	Description	Quantity	Unit	Unit Price	Extended Amount
----------	-------------	----------	------	------------	-----------------



710-11-101	PAINTED PAVT MARK,STD,WHITE,SOLID,6"	0.48 GM	\$1,080.33	\$518.56
711-15-201	THERMOPLASTIC, STD- OP,YELLOW, SOLID, 6"	0.48 GM	\$4,988.35	\$2,394.41
711-16-101	THERMOPLASTIC, STD-OTH, WHITE, SOLID, 6"	0.48 GM	\$3,986.79	\$1,913.66

#### Peripherals Subcomponent

Description	Value
Off Road Bike Path(s)	0
Off Road Bike Path Width L/R	0.00 / 0.00
Bike Path Structural Spread Rate	0
Noise Barrier Wall Length	0.00
Noise Barrier Wall Begin Height	0.00
Noise Barrier Wall End Height	0.00

#### Pay Items

Pay item	Description	Quantity Unit	Unit Price	Extended Amount
521-72-40	SHLDR CONC BARRIER,38" OR 44" HEIGHT	2,727.00 LF	\$306.25	\$835,143.75

#### Roadway Component Total

\$1,134,122.53

### SHOULDER COMPONENT

#### User Input Data

Description	Value
Total Outside Shoulder Width L/R	6.00 / 13.00
Total Outside Shoulder Perf. Turf Width L/R	0.00 / 0.00
Paved Outside Shoulder Width L/R	6.00 / 13.00
Structural Spread Rate	220
Friction Course Spread Rate	165
Total Width (T) / 8" Overlap (O)	T
Rumble Strips i; ½No. of Sides	2

#### Pay Items

Pay item	Description	Quantity Unit	Unit Price	Extended Amount
285-705	OPTIONAL BASE,BASE GROUP 05	2,768.13 SY	\$40.53	\$112,192.31
334-1-53	SUPERPAVE ASPH CONC, TRAF C, PG76-22	294.27 TN	\$127.05	\$37,387.00
337-7-83	ASPH CONC FC,TRAFFIC C,FC- 12.5,PG 76-22	220.70 TN	\$122.75	\$27,090.92
546-72-1	GROUND-IN RUMBLE STRIPS, 16"	0.48 GM	\$881.71	\$423.22

#### X-Items

Pay item	Description	Quantity Unit	Unit Price	Extended Amount
521-8-7	CONC BARRIER, W/JUNCT SL, 36 SS	600.00 LF	\$303.07	\$181,842.00

#### Erosion Control

#### Pay Items

Pay item	Description	Quantity Unit	Unit Price	Extended Amount
104-10-3	SEDIMENT BARRIER	3,294.72 LF	\$1.20	\$3,953.66
104-11	FLOATING TURBIDITY BARRIER	60.00 LF	\$9.49	\$569.40
104-12	STAKED TURBIDITY BARRIER- NYL REINF PVC	60.00 LF	\$4.44	\$266.40

104-15	SOIL TRACKING PREVENTION DEVICE	1.00 EA	\$2,988.11	\$2,988.11
107-1	LITTER REMOVAL	2.91 AC	\$20.76	\$60.41
107-2	MOWING	2.91 AC	\$46.89	\$136.45
<b>Shoulder Component Total</b>				<b>\$366,909.89</b>

**DRAINAGE COMPONENT**

**Pay Items**

Pay item	Description	Quantity Unit	Unit Price	Extended Amount
430-174-124	PIPE CULV, OPT MATL, ROUND,24"SD	192.00 LF	\$126.21	\$24,232.32
430-175-136	PIPE CULV, OPT MATL, ROUND, 36"S/CD	48.00 LF	\$342.26	\$16,428.48
430-984-129	MITERED END SECT, OPTIONAL RD, 24" SD	10.00 EA	\$2,253.96	\$22,539.60
570-1-1	PERFORMANCE TURF	168.96 SY	\$3.19	\$538.98
<b>Drainage Component Total</b>				<b>\$63,739.38</b>

**SIGNING COMPONENT**

**Pay Items**

Pay item	Description	Quantity Unit	Unit Price	Extended Amount
700-1-11	SINGLE POST SIGN, F&I GM, <12 SF	1.00 AS	\$380.22	\$380.22
700-1-12	SINGLE POST SIGN, F&I GM, 12-20 SF	5.00 AS	\$1,503.18	\$7,515.90
700-2-14	MULTI- POST SIGN, F&I GM, 31-50 SF	1.00 AS	\$5,637.01	\$5,637.01
<b>Signing Component Total</b>				<b>\$13,533.13</b>

**INTELLIGENT TRAFFIC SYSTEM (ITS) COMPONENT**

**Description of Work**

General ITS per LF of roadway.

**EX-Items**

Pay item	Description	Quantity Unit	Unit Price	Extended Amount
000-000	GENERAL ITS	3,176.00 LF	\$70.00	\$222,320.00
<b>Comment:</b> General ITS per LF of roadway.				
<b>Intelligent Traffic System (ITS) Component Total</b>				<b>\$222,320.00</b>

**LIGHTING COMPONENT**

**Rural Lighting Subcomponent**

**Description**

Multiplier (Number of Poles)

**Value**

17

**Pay Items**

Pay item	Description	Quantity Unit	Unit Price	Extended Amount
630-2-11	CONDUIT, F& I, OPEN TRENCH	3,400.00 LF	\$9.76	\$33,184.00
635-2-11	PULL & SPLICE BOX, F&I, 13" x 24"	17.00 EA	\$767.98	\$13,055.66

715-1-13	LIGHTING CONDUCTORS, F&I, INSUL, NO.4-2	10,200.00 LF	\$2.62	\$26,724.00
715-4-14	LIGHT POLE COMPLETE, F&I- STD, 45'	17.00 EA	\$7,063.23	\$120,074.91
715-500-1	POLE CABLE DIST SYS, CONVENTIONAL	17.00 EA	\$621.64	\$10,567.88
	<b>Subcomponent Total</b>			\$203,606.45
	<b>Lighting Component Total</b>			\$203,606.45

### LANDSCAPING COMPONENT

#### User Input Data

Description	Value
Cost %	2.00
Component Detail	N

**Landscaping Component Total** \$31,295.44

### BRIDGES COMPONENT

#### Bridge R-B3

Description	Value
Estimate Type	SF Estimate
Primary Estimate	YES
Length (LF)	1,795.00
Width (LF)	37.00
Type	High Level
Cost Factor	2.04
Structure No.	
Removal of Existing Structures area	0.00
Default Cost per SF	\$135.00
Factored Cost per SF	\$275.40
<b>Final Cost per SF</b>	<b>\$276.38</b>
<b>Basic Bridge Cost</b>	<b>\$18,290,691.00</b>

Description SR 538 RAMP B3: 1-LANE RAMP BRIDGE. EB I-4 GENERAL USE LANES TO SB SR 538.

#### Bridge Pay Items

Pay item	Description	Quantity	Unit	Unit Price	Extended Amount
400-2-10	CONC CLASS II, APPROACH SLABS	82.22	CY	\$588.22	\$48,363.45
415-1-9	REINF STEEL- APPROACH SLABS	14,388.50	LB	\$1.14	\$16,402.89
	<b>Bridge R-B3 Total</b>				\$18,355,457.34
	<b>Bridges Component Total</b>				\$18,355,457.34

### RETAINING WALLS COMPONENT

#### Retaining Wall 1

Description	Value
Length	660.00
Begin height	17.50
End Height	17.50
Multiplier	2

**Pay Items**

<b>Pay item</b>	<b>Description</b>	<b>Quantity</b>	<b>Unit</b>	<b>Unit Price</b>	<b>Extended Amount</b>
548-12	RET WALL SYSTEM, PERM, EX BARRIER	23,100.00	SF	\$36.17	\$835,527.00
<b>Retaining Walls Component Total</b>					\$835,527.00

---

**Sequence 20 Total** \$22,524,830.69

---

Sequence: 21 NUR - New Construction, Undivided, Rural

Net Length: 1.100 MI  
5,808 LF

Description: SR 538 Ramp C1: 2-Lane Ramp. NB SR 538 to EB I-4 General Use Lanes. Includes Shoulder Barrier, End Bent and Bridge R-C1.

### EARTHWORK COMPONENT

#### User Input Data

Description	Value
Standard Clearing and Grubbing Limits L/R	200.00 / 94.00
Incidental Clearing and Grubbing Area	0.00
Alignment Number	1
Distance	1.100
Top of Structural Course For Begin Section	117.50
Top of Structural Course For End Section	117.50
Horizontal Elevation For Begin Section	100.00
Horizontal Elevation For End Section	100.00
Front Slope L/R	6 to 1 / 6 to 1
Outside Shoulder Cross Slope L/R	5.00 % / 6.00 %
Roadway Cross Slope L/R	2.00 % / 2.00 %

#### Pay Items

Pay item	Description	Quantity	Unit	Unit Price	Extended Amount
110-1-1	CLEARING & GRUBBING	39.20	AC	\$21,000.00	\$823,200.00
120-6	EMBANKMENT	514,106.95	CY	\$20.88	\$10,734,553.12
<b>Earthwork Component Total</b>					<b>\$11,557,753.12</b>

### ROADWAY COMPONENT

#### User Input Data

Description	Value
Number of Lanes	2
Roadway Pavement Width L/R	12.00 / 12.00
Structural Spread Rate	440
Friction Course Spread Rate	165

#### Pay Items

Pay item	Description	Quantity	Unit	Unit Price	Extended Amount
160-4	TYPE B STABILIZATION	28,394.67	SY	\$11.66	\$331,081.85
285-712	OPTIONAL BASE,BASE GROUP 12	15,913.92	SY	\$73.16	\$1,164,262.39
334-1-53	SUPERPAVE ASPH CONC, TRAF C, PG76-22	3,407.36	TN	\$127.05	\$432,905.09
337-7-83	ASPH CONC FC,TRAFFIC C,FC-12.5,PG 76-22	1,277.76	TN	\$122.75	\$156,845.04

#### Pavement Marking Subcomponent

Description	Value
Include Thermo/Tape/Other	Y
Pavement Type	Asphalt
Solid Stripe No. of Paint Applications	1
Solid Stripe No. of Stripes	2
Skip Stripe No. of Paint Applications	1
Skip Stripe No. of Stripes	1

#### Pay Items

Pay item	Description	Quantity	Unit	Unit Price	Extended Amount
----------	-------------	----------	------	------------	-----------------

706-1-1	RAISED PAVMT MARK, TYPE B W/O FINAL SURF	148.00 EA	\$3.58	\$529.84
710-11-101	PAINTED PAVT MARK,STD,WHITE,SOLID,6"	2.20 GM	\$1,080.33	\$2,376.73
710-11-231	PAINTED PAVT MARK,STD,YELLOW,SKIP,6"	1.10 GM	\$487.22	\$535.94
711-15-201	THERMOPLASTIC, STD- OP,YELLOW, SOLID, 6"	2.20 GM	\$4,988.35	\$10,974.37
711-16-101	THERMOPLASTIC, STD-OTH, WHITE, SOLID, 6"	2.20 GM	\$3,986.79	\$8,770.94
711-16-231	THERMOPLASTIC, STD-OTH, YELLOW, SKIP, 6"	1.10 GM	\$1,339.37	\$1,473.31

#### Peripherals Subcomponent

Description	Value
Off Road Bike Path(s)	0
Off Road Bike Path Width L/R	0.00 / 0.00
Bike Path Structural Spread Rate	0
Noise Barrier Wall Length	0.00
Noise Barrier Wall Begin Height	0.00
Noise Barrier Wall End Height	0.00

#### Pay Items

Pay item	Description	Quantity Unit	Unit Price	Extended Amount
521-72-40	SHLDR CONC BARRIER,38" OR 44" HEIGHT	7,314.00 LF	\$306.25	\$2,239,912.50
<b>Roadway Component Total</b>				<b>\$4,349,668.00</b>

### SHOULDER COMPONENT

#### User Input Data

Description	Value
Total Outside Shoulder Width L/R	8.00 / 12.00
Total Outside Shoulder Perf. Turf Width L/R	0.00 / 0.00
Paved Outside Shoulder Width L/R	8.00 / 12.00
Structural Spread Rate	220
Friction Course Spread Rate	165
Total Width (T) / 8" Overlap (O)	T
Rumble Strips i; ½No. of Sides	2

#### Pay Items

Pay item	Description	Quantity Unit	Unit Price	Extended Amount
285-705	OPTIONAL BASE,BASE GROUP 05	13,332.59 SY	\$40.53	\$540,369.87
334-1-53	SUPERPAVE ASPH CONC, TRAF C, PG76-22	1,419.73 TN	\$127.05	\$180,376.70
337-7-83	ASPH CONC FC,TRAFFIC C,FC- 12.5,PG 76-22	1,064.80 TN	\$122.75	\$130,704.20
546-72-1	GROUND-IN RUMBLE STRIPS, 16"	2.20 GM	\$881.71	\$1,939.76

#### Erosion Control

#### Pay Items

Pay item	Description	Quantity Unit	Unit Price	Extended Amount
104-10-3	SEDIMENT BARRIER	15,100.80 LF	\$1.20	\$18,120.96
104-11	FLOATING TURBIDITY BARRIER	275.00 LF	\$9.49	\$2,609.75
104-12	STAKED TURBIDITY BARRIER- NYL REINF PVC	275.00 LF	\$4.44	\$1,221.00

104-15	SOIL TRACKING PREVENTION DEVICE	2.00 EA	\$2,988.11	\$5,976.22
107-1	LITTER REMOVAL	13.33 AC	\$20.76	\$276.73
107-2	MOWING	13.33 AC	\$46.89	\$625.04
<b>Shoulder Component Total</b>				<b>\$882,220.23</b>

**DRAINAGE COMPONENT**

**Pay Items**

Pay item	Description	Quantity Unit	Unit Price	Extended Amount
430-174-124	PIPE CULV, OPT MATL, ROUND,24"SD	880.00 LF	\$126.21	\$111,064.80
430-175-136	PIPE CULV, OPT MATL, ROUND, 36"S/CD	184.00 LF	\$342.26	\$62,975.84
430-984-129	MITERED END SECT, OPTIONAL RD, 24" SD	44.00 EA	\$2,253.96	\$99,174.24
570-1-1	PERFORMANCE TURF	774.40 SY	\$3.19	\$2,470.34
<b>Drainage Component Total</b>				<b>\$275,685.22</b>

**SIGNING COMPONENT**

**Pay Items**

Pay item	Description	Quantity Unit	Unit Price	Extended Amount
700-1-11	SINGLE POST SIGN, F&I GM, <12 SF	3.00 AS	\$380.22	\$1,140.66
700-1-12	SINGLE POST SIGN, F&I GM, 12- 20 SF	22.00 AS	\$1,503.18	\$33,069.96
700-2-14	MULTI- POST SIGN, F&I GM, 31-50 SF	3.00 AS	\$5,637.01	\$16,911.03
<b>Signing Component Total</b>				<b>\$51,121.65</b>

**INTELLIGENT TRAFFIC SYSTEM (ITS) COMPONENT**

**Description of Work**

General ITS per LF of roadway.

**EX-Items**

Pay item	Description	Quantity Unit	Unit Price	Extended Amount
000-000	GENERAL ITS	6,441.00 LF	\$70.00	\$450,870.00
<b>Comment:</b> General ITS per LF of roadway.				
<b>Intelligent Traffic System (ITS) Component Total</b>				<b>\$450,870.00</b>

**LIGHTING COMPONENT**

**Rural Lighting Subcomponent**

Description	Value
Multiplier (Number of Poles)	37

**Pay Items**

Pay item	Description	Quantity Unit	Unit Price	Extended Amount
630-2-11	CONDUIT, F& I, OPEN TRENCH	7,400.00 LF	\$9.76	\$72,224.00
635-2-11	PULL & SPLICE BOX, F&I, 13" x 24"	37.00 EA	\$767.98	\$28,415.26



715-1-13	LIGHTING CONDUCTORS, F&I, INSUL, NO.4-2	22,200.00 LF	\$2.62	\$58,164.00
715-4-14	LIGHT POLE COMPLETE, F&I- STD, 45'	37.00 EA	\$7,063.23	\$261,339.51
715-500-1	POLE CABLE DIST SYS, CONVENTIONAL	37.00 EA	\$621.64	\$23,000.68
	<b>Subcomponent Total</b>			\$443,143.45
	<b>Lighting Component Total</b>			\$443,143.45

### LANDSCAPING COMPONENT

#### User Input Data

Description	Value
Cost %	2.00
Component Detail	N

**Landscaping Component Total** \$110,151.47

### BRIDGES COMPONENT

#### Bridge R-C1

Description	Value
Estimate Type	SF Estimate
Primary Estimate	YES
Length (LF)	950.00
Width (LF)	45.00
Type	Elevated Roadway
Cost Factor	1.33
Structure No.	
Removal of Existing Structures area	0.00
Default Cost per SF	\$50.00
Factored Cost per SF	\$66.50
<b>Final Cost per SF</b>	<b>\$68.34</b>
<b>Basic Bridge Cost</b>	<b>\$2,842,875.00</b>

Description SR 538 NB RAMP C1 BRIDGE TO I-4 EASTBOUND  
GENERAL USE LANES

#### Bridge Pay Items

Pay item	Description	Quantity	Unit	Unit Price	Extended Amount
400-2-10	CONC CLASS II, APPROACH SLABS	100.00	CY	\$588.22	\$58,822.00
415-1-9	REINF STEEL- APPROACH SLABS	17,500.00	LB	\$1.14	\$19,950.00
	<b>Bridge R-C1 Total</b>				\$2,921,647.00
	<b>Bridges Component Total</b>				\$2,921,647.00

### RETAINING WALLS COMPONENT

#### Retaining Wall 1

Description	Value
Length	60.00
Begin height	17.50
End Height	17.50
Multiplier	2

**Pay Items**

<b>Pay item</b>	<b>Description</b>	<b>Quantity</b>	<b>Unit</b>	<b>Unit Price</b>	<b>Extended Amount</b>
548-12	RET WALL SYSTEM, PERM, EX BARRIER	2,100.00	SF	\$36.17	\$75,957.00
<b>Retaining Walls Component Total</b>					\$75,957.00

---

**Sequence 21 Total** \$21,118,217.14

---

Sequence: 22 NUR - New Construction, Undivided, Rural

Net Length: 0.900 MI  
4,752 LF

Description: SR 429 Ramp C2: 1-Lane Ramp. SB SR 429 C-D Road to EB I-4 General Use Lanes. Includes Shoulder Barrier and Retaining Wall and Bridge R-C2.

**EARTHWORK COMPONENT**

**User Input Data**

Description	Value
Standard Clearing and Grubbing Limits L/R	50.00 / 94.00
Incidental Clearing and Grubbing Area	0.00
Alignment Number	1
Distance	0.900
Top of Structural Course For Begin Section	117.50
Top of Structural Course For End Section	117.50
Horizontal Elevation For Begin Section	100.00
Horizontal Elevation For End Section	100.00
Front Slope L/R	6 to 1 / 6 to 1
Outside Shoulder Cross Slope L/R	5.00 % / 6.00 %
Roadway Cross Slope L/R	2.00 % / 2.00 %

**Pay Items**

Pay item	Description	Quantity	Unit	Unit Price	Extended Amount
110-1-1	CLEARING & GRUBBING	15.71	AC	\$21,000.00	\$329,910.00
120-6	EMBANKMENT	209,716.32	CY	\$20.88	\$4,378,876.76
<b>Earthwork Component Total</b>					<b>\$4,708,786.76</b>

**ROADWAY COMPONENT**

**User Input Data**

Description	Value
Number of Lanes	1
Roadway Pavement Width L/R	0.00 / 15.00
Structural Spread Rate	440
Friction Course Spread Rate	165

**Pay Items**

Pay item	Description	Quantity	Unit	Unit Price	Extended Amount
160-4	TYPE B STABILIZATION	18,216.00	SY	\$11.66	\$212,398.56
285-712	OPTIONAL BASE,BASE GROUP 12	8,094.24	SY	\$73.16	\$592,174.60
334-1-53	SUPERPAVE ASPH CONC, TRAF C, PG76-22	1,742.40	TN	\$127.05	\$221,371.92
337-7-83	ASPH CONC FC,TRAFFIC C,FC-12.5,PG 76-22	653.40	TN	\$122.75	\$80,204.85

**Pavement Marking Subcomponent**

Description	Value
Include Thermo/Tape/Other	Y
Pavement Type	Asphalt
Solid Stripe No. of Paint Applications	1
Solid Stripe No. of Stripes	2
Skip Stripe No. of Paint Applications	1
Skip Stripe No. of Stripes	0

**Pay Items**

Pay item	Description	Quantity	Unit	Unit Price	Extended Amount
----------	-------------	----------	------	------------	-----------------

710-11-101	PAINTED PAVT MARK,STD,WHITE,SOLID,6"	1.80 GM	\$1,080.33	\$1,944.59
711-15-201	THERMOPLASTIC, STD- OP,YELLOW, SOLID, 6"	1.80 GM	\$4,988.35	\$8,979.03
711-16-101	THERMOPLASTIC, STD-OTH, WHITE, SOLID, 6"	1.80 GM	\$3,986.79	\$7,176.22

#### Peripherals Subcomponent

Description	Value
Off Road Bike Path(s)	0
Off Road Bike Path Width L/R	0.00 / 0.00
Bike Path Structural Spread Rate	0
Noise Barrier Wall Length	0.00
Noise Barrier Wall Begin Height	0.00
Noise Barrier Wall End Height	0.00

#### Pay Items

Pay item	Description	Quantity Unit	Unit Price	Extended Amount
521-72-40	SHLDR CONC BARRIER,38" OR 44" HEIGHT	2,433.00 LF	\$306.25	\$745,106.25

#### Roadway Component Total

\$1,869,356.02

### SHOULDER COMPONENT

#### User Input Data

Description	Value
Total Outside Shoulder Width L/R	13.50 / 6.00
Total Outside Shoulder Perf. Turf Width L/R	0.00 / 0.00
Paved Outside Shoulder Width L/R	13.50 / 6.00
Structural Spread Rate	220
Friction Course Spread Rate	165
Total Width (T) / 8" Overlap (O)	T
Rumble Strips i; ½No. of Sides	2

#### Pay Items

Pay item	Description	Quantity Unit	Unit Price	Extended Amount
285-705	OPTIONAL BASE,BASE GROUP 05	10,644.48 SY	\$40.53	\$431,420.77
334-1-53	SUPERPAVE ASPH CONC, TRAF C, PG76-22	1,132.56 TN	\$127.05	\$143,891.75
337-7-83	ASPH CONC FC,TRAFFIC C,FC- 12.5,PG 76-22	849.42 TN	\$122.75	\$104,266.30
546-72-1	GROUND-IN RUMBLE STRIPS, 16"	1.80 GM	\$881.71	\$1,587.08

#### X-Items

Pay item	Description	Quantity Unit	Unit Price	Extended Amount
521-8-7	CONC BARRIER, W/JUNCT SL, 36 SS	627.00 LF	\$303.07	\$190,024.89

#### Erosion Control

#### Pay Items

Pay item	Description	Quantity Unit	Unit Price	Extended Amount
104-10-3	SEDIMENT BARRIER	12,355.20 LF	\$1.20	\$14,826.24
104-11	FLOATING TURBIDITY BARRIER	225.00 LF	\$9.49	\$2,135.25
104-12	STAKED TURBIDITY BARRIER- NYL REINF PVC	225.00 LF	\$4.44	\$999.00

104-15	SOIL TRACKING PREVENTION DEVICE	1.00 EA	\$2,988.11	\$2,988.11
107-1	LITTER REMOVAL	10.91 AC	\$20.76	\$226.49
107-2	MOWING	10.91 AC	\$46.89	\$511.57
<b>Shoulder Component Total</b>				<b>\$892,877.46</b>

**DRAINAGE COMPONENT**

**Pay Items**

Pay item	Description	Quantity Unit	Unit Price	Extended Amount
430-174-124	PIPE CULV, OPT MATL, ROUND,24"SD	720.00 LF	\$126.21	\$90,871.20
430-175-136	PIPE CULV, OPT MATL, ROUND, 36"S/CD	152.00 LF	\$342.26	\$52,023.52
430-984-129	MITERED END SECT, OPTIONAL RD, 24" SD	36.00 EA	\$2,253.96	\$81,142.56
570-1-1	PERFORMANCE TURF	633.60 SY	\$3.19	\$2,021.18
<b>Drainage Component Total</b>				<b>\$226,058.46</b>

**SIGNING COMPONENT**

**Pay Items**

Pay item	Description	Quantity Unit	Unit Price	Extended Amount
700-1-11	SINGLE POST SIGN, F&I GM, <12 SF	2.00 AS	\$380.22	\$760.44
700-1-12	SINGLE POST SIGN, F&I GM, 12-20 SF	18.00 AS	\$1,503.18	\$27,057.24
700-2-14	MULTI- POST SIGN, F&I GM, 31-50 SF	2.00 AS	\$5,637.01	\$11,274.02
<b>Signing Component Total</b>				<b>\$39,091.70</b>

**INTELLIGENT TRAFFIC SYSTEM (ITS) COMPONENT**

**Description of Work**

General ITS per LF of roadway.

**EX-Items**

Pay item	Description	Quantity Unit	Unit Price	Extended Amount
000-000	GENERAL ITS	7,026.00 LF	\$70.00	\$491,820.00
<b>Comment:</b> General ITS per LF of roadway.				
<b>Intelligent Traffic System (ITS) Component Total</b>				<b>\$491,820.00</b>

**LIGHTING COMPONENT**

**Rural Lighting Subcomponent**

Description	Value
Multiplier (Number of Poles)	44

**Pay Items**

Pay item	Description	Quantity Unit	Unit Price	Extended Amount
630-2-11	CONDUIT, F& I, OPEN TRENCH	8,800.00 LF	\$9.76	\$85,888.00
635-2-11	PULL & SPLICE BOX, F&I, 13" x 24"	44.00 EA	\$767.98	\$33,791.12

715-1-13	LIGHTING CONDUCTORS, F&I, INSUL, NO.4-2	26,400.00 LF	\$2.62	\$69,168.00
715-4-14	LIGHT POLE COMPLETE, F&I- STD, 45'	44.00 EA	\$7,063.23	\$310,782.12
715-500-1	POLE CABLE DIST SYS, CONVENTIONAL	44.00 EA	\$621.64	\$27,352.16
	<b>Subcomponent Total</b>			\$526,981.40
	<b>Lighting Component Total</b>			\$526,981.40

### LANDSCAPING COMPONENT

#### User Input Data

Description	Value
Cost %	2.00
Component Detail	N

**Landscaping Component Total** \$59,765.84

### BRIDGES COMPONENT

#### Bridge R-C2

Description	Value
Estimate Type	SF Estimate
Primary Estimate	YES
Length (LF)	4,910.00
Width (LF)	38.00
Type	High Level
Cost Factor	2.04
Structure No.	
Removal of Existing Structures area	0.00
Default Cost per SF	\$135.00
Factored Cost per SF	\$275.40
<b>Final Cost per SF</b>	<b>\$275.76</b>
<b>Basic Bridge Cost</b>	<b>\$51,384,132.00</b>

Description SR 429 RAMP C2: 1-LANE RAMP BRIDGE. SB SR 429 C-D ROAD TO EB I-4 GENERAL USE LANES.

#### Bridge Pay Items

Pay item	Description	Quantity	Unit	Unit Price	Extended Amount
400-2-10	CONC CLASS II, APPROACH SLABS	84.44	CY	\$588.22	\$49,669.30
415-1-9	REINF STEEL- APPROACH SLABS	14,777.00	LB	\$1.14	\$16,845.78
	<b>Bridge R-C2 Total</b>				\$51,450,647.08
	<b>Bridges Component Total</b>				\$51,450,647.08

### RETAINING WALLS COMPONENT

#### Retaining Wall 1

Description	Value
Length	723.00
Begin height	17.50
End Height	17.50
Multiplier	2

**Pay Items**

<b>Pay item</b>	<b>Description</b>	<b>Quantity</b>	<b>Unit</b>	<b>Unit Price</b>	<b>Extended Amount</b>
548-12	RET WALL SYSTEM, PERM, EX BARRIER	25,305.00	SF	\$36.17	\$915,281.85
<b>Retaining Walls Component Total</b>					\$915,281.86

---

**Sequence 22 Total** \$61,180,666.58

---



Sequence: 23 NUR - New Construction, Undivided, Rural

Net Length: 0.620 MI  
3,274 LF

Description: SR 538 Ramp C3: 1-Lane Ramp. NB SR 538 to EB I-4 Express Lanes. Includes Shoulder Barrier, Retaining Wall and Bridge.

### EARTHWORK COMPONENT

#### User Input Data

Description	Value
Standard Clearing and Grubbing Limits L/R	150.00 / 150.00
Incidental Clearing and Grubbing Area	0.00
Alignment Number	1
Distance	0.620
Top of Structural Course For Begin Section	117.50
Top of Structural Course For End Section	117.50
Horizontal Elevation For Begin Section	100.00
Horizontal Elevation For End Section	100.00
Front Slope L/R	6 to 1 / 6 to 1
Outside Shoulder Cross Slope L/R	5.00 % / 6.00 %
Roadway Cross Slope L/R	2.00 % / 2.00 %

#### Pay Items

Pay item	Description	Quantity	Unit	Unit Price	Extended Amount
110-1-1	CLEARING & GRUBBING	22.55	AC	\$21,000.00	\$473,550.00
120-6	EMBANKMENT	144,471.24	CY	\$20.88	\$3,016,559.49
<b>Earthwork Component Total</b>					<b>\$3,490,109.49</b>

### ROADWAY COMPONENT

#### User Input Data

Description	Value
Number of Lanes	1
Roadway Pavement Width L/R	0.00 / 15.00
Structural Spread Rate	440
Friction Course Spread Rate	165

#### Pay Items

Pay item	Description	Quantity	Unit	Unit Price	Extended Amount
160-4	TYPE B STABILIZATION	9,820.80	SY	\$11.66	\$114,510.53
285-712	OPTIONAL BASE,BASE GROUP 12	5,576.03	SY	\$73.16	\$407,942.35
334-1-53	SUPERPAVE ASPH CONC, TRAF C, PG76-22	1,200.32	TN	\$127.05	\$152,500.66
337-7-83	ASPH CONC FC,TRAFFIC C,FC-12.5,PG 76-22	450.12	TN	\$122.75	\$55,252.23

#### Pavement Marking Subcomponent

Description	Value
Include Thermo/Tape/Other	Y
Pavement Type	Asphalt
Solid Stripe No. of Paint Applications	1
Solid Stripe No. of Stripes	2
Skip Stripe No. of Paint Applications	1
Skip Stripe No. of Stripes	0

#### Pay Items

Pay item	Description	Quantity	Unit	Unit Price	Extended Amount
----------	-------------	----------	------	------------	-----------------

710-11-101	PAINTED PAVT MARK,STD,WHITE,SOLID,6"	1.24 GM	\$1,080.33	\$1,339.61
711-15-201	THERMOPLASTIC, STD- OP,YELLOW, SOLID, 6"	1.24 GM	\$4,988.35	\$6,185.55
711-16-101	THERMOPLASTIC, STD-OTH, WHITE, SOLID, 6"	1.24 GM	\$3,986.79	\$4,943.62

#### Peripherals Subcomponent

Description	Value
Off Road Bike Path(s)	0
Off Road Bike Path Width L/R	0.00 / 0.00
Bike Path Structural Spread Rate	0
Noise Barrier Wall Length	0.00
Noise Barrier Wall Begin Height	0.00
Noise Barrier Wall End Height	0.00

#### Pay Items

Pay item	Description	Quantity Unit	Unit Price	Extended Amount
521-72-40	SHLDR CONC BARRIER,38" OR 44" HEIGHT	1,022.00 LF	\$306.25	\$312,987.50

#### Roadway Component Total

\$1,055,662.05

### SHOULDER COMPONENT

#### User Input Data

Description	Value
Total Outside Shoulder Width L/R	6.00 / 6.00
Total Outside Shoulder Perf. Turf Width L/R	0.00 / 0.00
Paved Outside Shoulder Width L/R	6.00 / 6.00
Structural Spread Rate	220
Friction Course Spread Rate	165
Total Width (T) / 8" Overlap (O)	T
Rumble Strips i; ½No. of Sides	2

#### Pay Items

Pay item	Description	Quantity Unit	Unit Price	Extended Amount
285-705	OPTIONAL BASE,BASE GROUP 05	4,604.86 SY	\$40.53	\$186,634.98
334-1-53	SUPERPAVE ASPH CONC, TRAF C, PG76-22	480.13 TN	\$127.05	\$61,000.52
337-7-83	ASPH CONC FC,TRAFFIC C,FC- 12.5,PG 76-22	360.10 TN	\$122.75	\$44,202.28
546-72-1	GROUND-IN RUMBLE STRIPS, 16"	1.24 GM	\$881.71	\$1,093.32

#### X-Items

Pay item	Description	Quantity Unit	Unit Price	Extended Amount
521-8-7	CONC BARRIER, W/JUNCT SL, 36 SS	800.00 LF	\$303.07	\$242,456.00

#### Erosion Control

#### Pay Items

Pay item	Description	Quantity Unit	Unit Price	Extended Amount
104-10-3	SEDIMENT BARRIER	8,511.36 LF	\$1.20	\$10,213.63
104-11	FLOATING TURBIDITY BARRIER	155.00 LF	\$9.49	\$1,470.95
104-12	STAKED TURBIDITY BARRIER- NYL REINF PVC	155.00 LF	\$4.44	\$688.20

104-15	SOIL TRACKING PREVENTION DEVICE	1.00 EA	\$2,988.11	\$2,988.11
107-1	LITTER REMOVAL	7.51 AC	\$20.76	\$155.91
107-2	MOWING	7.51 AC	\$46.89	\$352.14
<b>Shoulder Component Total</b>				<b>\$551,256.04</b>

**DRAINAGE COMPONENT**

**Pay Items**

Pay item	Description	Quantity Unit	Unit Price	Extended Amount
430-174-124	PIPE CULV, OPT MATL, ROUND,24"SD	496.00 LF	\$126.21	\$62,600.16
430-175-136	PIPE CULV, OPT MATL, ROUND, 36"S/CD	112.00 LF	\$342.26	\$38,333.12
430-984-129	MITERED END SECT, OPTIONAL RD, 24" SD	25.00 EA	\$2,253.96	\$56,349.00
570-1-1	PERFORMANCE TURF	436.48 SY	\$3.19	\$1,392.37
<b>Drainage Component Total</b>				<b>\$158,674.65</b>

**SIGNING COMPONENT**

**Pay Items**

Pay item	Description	Quantity Unit	Unit Price	Extended Amount
700-1-11	SINGLE POST SIGN, F&I GM, <12 SF	2.00 AS	\$380.22	\$760.44
700-1-12	SINGLE POST SIGN, F&I GM, 12-20 SF	13.00 AS	\$1,503.18	\$19,541.34
700-2-14	MULTI- POST SIGN, F&I GM, 31-50 SF	2.00 AS	\$5,637.01	\$11,274.02
<b>Signing Component Total</b>				<b>\$31,575.80</b>

**INTELLIGENT TRAFFIC SYSTEM (ITS) COMPONENT**

**Description of Work**

General ITS per LF of roadway.

**EX-Items**

Pay item	Description	Quantity Unit	Unit Price	Extended Amount
000-000	GENERAL ITS	1,931.00 LF	\$70.00	\$135,170.00
<b>Comment:</b> General ITS per LF of roadway.				
<b>Intelligent Traffic System (ITS) Component Total</b>				<b>\$135,170.00</b>

**LIGHTING COMPONENT**

**Rural Lighting Subcomponent**

**Description**

Multiplier (Number of Poles)

**Value**

11

**Pay Items**

Pay item	Description	Quantity Unit	Unit Price	Extended Amount
630-2-11	CONDUIT, F& I, OPEN TRENCH	2,200.00 LF	\$9.76	\$21,472.00
635-2-11	PULL & SPLICE BOX, F&I, 13" x 24"	11.00 EA	\$767.98	\$8,447.78

715-1-13	LIGHTING CONDUCTORS, F&I, INSUL, NO.4-2	6,600.00 LF	\$2.62	\$17,292.00
715-4-14	LIGHT POLE COMPLETE, F&I- STD, 45'	11.00 EA	\$7,063.23	\$77,695.53
715-500-1	POLE CABLE DIST SYS, CONVENTIONAL	11.00 EA	\$621.64	\$6,838.04
	<b>Subcomponent Total</b>			\$131,745.35
	<b>Lighting Component Total</b>			\$131,745.35

### LANDSCAPING COMPONENT

#### User Input Data

Description	Value
Cost %	2.00
Component Detail	N

**Landscaping Component Total** \$35,311.85

### BRIDGES COMPONENT

#### Bridge R-C3

Description	Value
Estimate Type	SF Estimate
Primary Estimate	YES
Length (LF)	950.00
Width (LF)	40.00
Type	High Level
Cost Factor	2.04
Structure No.	
Removal of Existing Structures area	0.00
Default Cost per SF	\$135.00
Factored Cost per SF	\$275.40
<b>Final Cost per SF</b>	<b>\$277.24</b>
<b>Basic Bridge Cost</b>	<b>\$10,465,200.00</b>

Description SR 538 RAMP C3: 1-LANE RAMP BRIDGE 2. NB SR 538 TO  
EB I-4 EXPRESS LANES.

#### Bridge Pay Items

Pay item	Description	Quantity	Unit	Unit Price	Extended Amount
400-2-10	CONC CLASS II, APPROACH SLABS	88.89	CY	\$588.22	\$52,286.88
415-1-9	REINF STEEL- APPROACH SLABS	15,555.75	LB	\$1.14	\$17,733.56
	<b>Bridge R-C3 Total</b>				\$10,535,220.44
	<b>Bridges Component Total</b>				\$10,535,220.44

### RETAINING WALLS COMPONENT

#### Retaining Wall 1

Description	Value
Length	860.00
Begin height	17.50
End Height	17.50
Multiplier	2

**Pay Items**

<b>Pay item</b>	<b>Description</b>	<b>Quantity</b>	<b>Unit</b>	<b>Unit Price</b>	<b>Extended Amount</b>
548-12	RET WALL SYSTEM, PERM, EX BARRIER	30,100.00	SF	\$36.17	\$1,088,717.00
<b>Retaining Walls Component Total</b>					\$1,088,717.00

---

**Sequence 23 Total** \$17,213,442.67

---

Sequence: 24 NUR - New Construction, Undivided, Rural

Net Length: 0.650 MI  
3,432 LF

Description: SR 538 Ramp D1: 1-Lane Ramp. WB I-4 Express Lanes to Ramp D2 for SB SR 538. Includes Shoulder Barrier, Retaining Wall and Bridge.

### EARTHWORK COMPONENT

#### User Input Data

Description	Value
Standard Clearing and Grubbing Limits L/R	75.00 / 94.00
Incidental Clearing and Grubbing Area	0.00
Alignment Number	1
Distance	0.650
Top of Structural Course For Begin Section	117.50
Top of Structural Course For End Section	117.50
Horizontal Elevation For Begin Section	100.00
Horizontal Elevation For End Section	100.00
Front Slope L/R	6 to 1 / 6 to 1
Outside Shoulder Cross Slope L/R	5.00 % / 6.00 %
Roadway Cross Slope L/R	2.00 % / 2.00 %

#### Pay Items

Pay item	Description	Quantity	Unit	Unit Price	Extended Amount
110-1-1	CLEARING & GRUBBING	13.32	AC	\$21,000.00	\$279,720.00
120-6	EMBANKMENT	151,461.79	CY	\$20.88	\$3,162,522.18
<b>Earthwork Component Total</b>					<b>\$3,442,242.18</b>

### ROADWAY COMPONENT

#### User Input Data

Description	Value
Number of Lanes	1
Roadway Pavement Width L/R	0.00 / 15.00
Structural Spread Rate	440
Friction Course Spread Rate	165

#### Pay Items

Pay item	Description	Quantity	Unit	Unit Price	Extended Amount
160-4	TYPE B STABILIZATION	10,296.00	SY	\$11.66	\$120,051.36
285-712	OPTIONAL BASE,BASE GROUP 12	5,845.84	SY	\$73.16	\$427,681.65
334-1-53	SUPERPAVE ASPH CONC, TRAF C, PG76-22	1,258.40	TN	\$127.05	\$159,879.72
337-7-83	ASPH CONC FC,TRAFFIC C,FC-12.5,PG 76-22	471.90	TN	\$122.75	\$57,925.72

#### Pavement Marking Subcomponent

Description	Value
Include Thermo/Tape/Other	Y
Pavement Type	Asphalt
Solid Stripe No. of Paint Applications	1
Solid Stripe No. of Stripes	2
Skip Stripe No. of Paint Applications	1
Skip Stripe No. of Stripes	0

#### Pay Items

Pay item	Description	Quantity	Unit	Unit Price	Extended Amount
----------	-------------	----------	------	------------	-----------------

710-11-101	PAINTED PAVT MARK,STD,WHITE,SOLID,6"	1.30 GM	\$1,080.33	\$1,404.43
711-15-201	THERMOPLASTIC, STD- OP,YELLOW, SOLID, 6"	1.30 GM	\$4,988.35	\$6,484.86
711-16-101	THERMOPLASTIC, STD-OTH, WHITE, SOLID, 6"	1.30 GM	\$3,986.79	\$5,182.83

#### Peripherals Subcomponent

Description	Value
Off Road Bike Path(s)	0
Off Road Bike Path Width L/R	0.00 / 0.00
Bike Path Structural Spread Rate	0
Noise Barrier Wall Length	0.00
Noise Barrier Wall Begin Height	0.00
Noise Barrier Wall End Height	0.00

#### Pay Items

Pay item	Description	Quantity Unit	Unit Price	Extended Amount
521-72-40	SHLDR CONC BARRIER,38" OR 44" HEIGHT	4,155.00 LF	\$306.25	\$1,272,468.75

#### Roadway Component Total

\$2,051,079.33

### SHOULDER COMPONENT

#### User Input Data

Description	Value
Total Outside Shoulder Width L/R	6.00 / 6.00
Total Outside Shoulder Perf. Turf Width L/R	0.00 / 0.00
Paved Outside Shoulder Width L/R	6.00 / 6.00
Structural Spread Rate	220
Friction Course Spread Rate	165
Total Width (T) / 8" Overlap (O)	T
Rumble Strips i; ½No. of Sides	2

#### Pay Items

Pay item	Description	Quantity Unit	Unit Price	Extended Amount
285-705	OPTIONAL BASE,BASE GROUP 05	4,827.68 SY	\$40.53	\$195,665.87
334-1-53	SUPERPAVE ASPH CONC, TRAF C, PG76-22	503.36 TN	\$127.05	\$63,951.89
337-7-83	ASPH CONC FC,TRAFFIC C,FC- 12.5,PG 76-22	377.52 TN	\$122.75	\$46,340.58
546-72-1	GROUND-IN RUMBLE STRIPS, 16"	1.30 GM	\$881.71	\$1,146.22

#### X-Items

Pay item	Description	Quantity Unit	Unit Price	Extended Amount
521-8-7	CONC BARRIER, W/JUNCT SL, 36 SS	1,340.00 LF	\$303.07	\$406,113.80

#### Erosion Control

#### Pay Items

Pay item	Description	Quantity Unit	Unit Price	Extended Amount
104-10-3	SEDIMENT BARRIER	8,923.20 LF	\$1.20	\$10,707.84
104-11	FLOATING TURBIDITY BARRIER	162.50 LF	\$9.49	\$1,542.12
104-12	STAKED TURBIDITY BARRIER- NYL REINF PVC	162.50 LF	\$4.44	\$721.50



104-15	SOIL TRACKING PREVENTION DEVICE	1.00 EA	\$2,988.11	\$2,988.11
107-1	LITTER REMOVAL	7.88 AC	\$20.76	\$163.59
107-2	MOWING	7.88 AC	\$46.89	\$369.49
<b>Shoulder Component Total</b>				<b>\$729,711.02</b>

**DRAINAGE COMPONENT**

**Pay Items**

Pay item	Description	Quantity Unit	Unit Price	Extended Amount
430-174-124	PIPE CULV, OPT MATL, ROUND,24"SD	520.00 LF	\$126.21	\$65,629.20
430-175-136	PIPE CULV, OPT MATL, ROUND, 36"S/CD	112.00 LF	\$342.26	\$38,333.12
430-984-129	MITERED END SECT, OPTIONAL RD, 24" SD	26.00 EA	\$2,253.96	\$58,602.96
570-1-1	PERFORMANCE TURF	457.60 SY	\$3.19	\$1,459.74
<b>Drainage Component Total</b>				<b>\$164,025.02</b>

**SIGNING COMPONENT**

**Pay Items**

Pay item	Description	Quantity Unit	Unit Price	Extended Amount
700-1-11	SINGLE POST SIGN, F&I GM, <12 SF	2.00 AS	\$380.22	\$760.44
700-1-12	SINGLE POST SIGN, F&I GM, 12-20 SF	13.00 AS	\$1,503.18	\$19,541.34
700-2-14	MULTI- POST SIGN, F&I GM, 31-50 SF	2.00 AS	\$5,637.01	\$11,274.02
<b>Signing Component Total</b>				<b>\$31,575.80</b>

**INTELLIGENT TRAFFIC SYSTEM (ITS) COMPONENT**

**Description of Work**

General ITS per LF of roadway.

**EX-Items**

Pay item	Description	Quantity Unit	Unit Price	Extended Amount
000-000	GENERAL ITS	4,117.00 LF	\$70.00	\$288,190.00
<b>Comment:</b> General ITS per LF of roadway.				
<b>Intelligent Traffic System (ITS) Component Total</b>				<b>\$288,190.00</b>

**LIGHTING COMPONENT**

**Rural Lighting Subcomponent**

Description	Value
Multiplier (Number of Poles)	22

**Pay Items**

Pay item	Description	Quantity Unit	Unit Price	Extended Amount
630-2-11	CONDUIT, F& I, OPEN TRENCH	4,400.00 LF	\$9.76	\$42,944.00
635-2-11	PULL & SPLICE BOX, F&I, 13" x 24"	22.00 EA	\$767.98	\$16,895.56

715-1-13	LIGHTING CONDUCTORS, F&I, INSUL, NO.4-2	13,200.00 LF	\$2.62	\$34,584.00
715-4-14	LIGHT POLE COMPLETE, F&I- STD, 45'	22.00 EA	\$7,063.23	\$155,391.06
715-500-1	POLE CABLE DIST SYS, CONVENTIONAL	22.00 EA	\$621.64	\$13,676.08
	<b>Subcomponent Total</b>			\$263,490.70
	<b>Lighting Component Total</b>			\$263,490.70

### LANDSCAPING COMPONENT

#### User Input Data

Description	Value
Cost %	2.00
Component Detail	N

**Landscaping Component Total** \$58,896.31

### BRIDGES COMPONENT

#### Bridge R-D1\_1

Description	Value
Estimate Type	SF Estimate
Primary Estimate	YES
Length (LF)	634.00
Width (LF)	30.00
Type	High Level
Cost Factor	2.04
Structure No.	
Removal of Existing Structures area	0.00
Default Cost per SF	\$135.00
Factored Cost per SF	\$275.40
<b>Final Cost per SF</b>	<b>\$278.16</b>
<b>Basic Bridge Cost</b>	<b>\$5,238,108.00</b>

Description SR 538 RAMP D1: 1-LANE RAMP. WB I-4 EXPRESS LANES TO RAMP D2 FOR SB SR 538.

#### Bridge Pay Items

Pay item	Description	Quantity	Unit	Unit Price	Extended Amount
400-2-10	CONC CLASS II, APPROACH SLABS	66.67	CY	\$588.22	\$39,216.63
415-1-9	REINF STEEL- APPROACH SLABS	11,667.25	LB	\$1.14	\$13,300.66
	<b>Bridge R-D1_1 Total</b>				\$5,290,625.30

#### Bridge R-D1\_2

Description	Value
Estimate Type	SF Estimate
Primary Estimate	YES
Length (LF)	475.00
Width (LF)	30.00
Type	High Level
Cost Factor	2.04
Structure No.	
Removal of Existing Structures area	0.00
Default Cost per SF	\$135.00
Factored Cost per SF	\$275.40

**Final Cost per SF**  
**Basic Bridge Cost**

**\$279.09**  
**\$3,924,450.00**

Description

SR 538 RAMP D1: 1-LANE RAMP. WB I-4 EXPRESS LANES  
TO RAMP D2 FOR SB SR 538.

**Bridge Pay Items**

<b>Pay item</b>	<b>Description</b>	<b>Quantity Unit</b>	<b>Unit Price</b>	<b>Extended Amount</b>
400-2-10	CONC CLASS II, APPROACH SLABS	66.67 CY	\$588.22	\$39,216.63
415-1-9	REINF STEEL- APPROACH SLABS	11,667.25 LB	\$1.14	\$13,300.66
<b>Bridge R-D1_2 Total</b>				<b>\$3,976,967.30</b>
<b>Bridges Component Total</b>				<b>\$9,267,592.60</b>

---

**RETAINING WALLS COMPONENT**

**Retaining Wall 1**

<b>Description</b>	<b>Value</b>
Length	1,508.00
Begin height	17.50
End Height	17.50
Multiplier	2

**Pay Items**

<b>Pay item</b>	<b>Description</b>	<b>Quantity Unit</b>	<b>Unit Price</b>	<b>Extended Amount</b>
548-12	RET WALL SYSTEM, PERM, EX BARRIER	52,780.00 SF	\$36.17	\$1,909,052.60
<b>Retaining Walls Component Total</b>				<b>\$1,909,052.60</b>

---

**Sequence 24 Total**

**\$18,205,855.56**

---

Sequence: 25 NUR - New Construction, Undivided, Rural

Net Length: 1.220 MI  
6,442 LF

Description: SR 538 Ramp D2: 2-Lane Ramp. WB I-4 General Use Lanes to SB SR 538. Includes Shoulder Barrier, Retaining Wall and Bridges R-D2\_1 AND R-D2\_2.

### EARTHWORK COMPONENT

#### User Input Data

Description	Value
Standard Clearing and Grubbing Limits L/R	100.00 / 100.00
Incidental Clearing and Grubbing Area	0.00
Alignment Number	1
Distance	1.220
Top of Structural Course For Begin Section	117.50
Top of Structural Course For End Section	117.50
Horizontal Elevation For Begin Section	100.00
Horizontal Elevation For End Section	100.00
Front Slope L/R	1 to 1 / 1 to 1
Outside Shoulder Cross Slope L/R	5.00 % / 6.00 %
Roadway Cross Slope L/R	2.00 % / 2.00 %

#### Pay Items

Pay item	Description	Quantity	Unit	Unit Price	Extended Amount
110-1-1	CLEARING & GRUBBING	29.58	AC	\$21,000.00	\$621,180.00
120-6	EMBANKMENT	252,183.87	CY	\$20.88	\$5,265,599.21
<b>Earthwork Component Total</b>					<b>\$5,886,779.21</b>

### ROADWAY COMPONENT

#### User Input Data

Description	Value
Number of Lanes	2
Roadway Pavement Width L/R	12.00 / 12.00
Structural Spread Rate	440
Friction Course Spread Rate	165

#### Pay Items

Pay item	Description	Quantity	Unit	Unit Price	Extended Amount
160-4	TYPE B STABILIZATION	34,355.20	SY	\$11.66	\$400,581.63
285-712	OPTIONAL BASE,BASE GROUP 12	17,649.98	SY	\$73.16	\$1,291,272.54
334-1-53	SUPERPAVE ASPH CONC, TRAF C, PG76-22	3,779.07	TN	\$127.05	\$480,130.84
337-7-83	ASPH CONC FC,TRAFFIC C,FC-12.5,PG 76-22	1,417.15	TN	\$122.75	\$173,955.16

#### Pavement Marking Subcomponent

Description	Value
Include Thermo/Tape/Other	Y
Pavement Type	Asphalt
Solid Stripe No. of Paint Applications	1
Solid Stripe No. of Stripes	2
Skip Stripe No. of Paint Applications	1
Skip Stripe No. of Stripes	1

#### Pay Items

Pay item	Description	Quantity	Unit	Unit Price	Extended Amount
----------	-------------	----------	------	------------	-----------------

706-1-1	RAISED PAVMT MARK, TYPE B W/O FINAL SURF	165.00 EA	\$3.58	\$590.70
710-11-101	PAINTED PAVT MARK,STD,WHITE,SOLID,6"	2.44 GM	\$1,080.33	\$2,636.01
710-11-231	PAINTED PAVT MARK,STD,YELLOW,SKIP,6"	1.22 GM	\$487.22	\$594.41
711-15-201	THERMOPLASTIC, STD- OP,YELLOW, SOLID, 6"	2.44 GM	\$4,988.35	\$12,171.57
711-16-101	THERMOPLASTIC, STD-OTH, WHITE, SOLID, 6"	2.44 GM	\$3,986.79	\$9,727.77
711-16-231	THERMOPLASTIC, STD-OTH, YELLOW, SKIP, 6"	1.22 GM	\$1,339.37	\$1,634.03

#### Peripherals Subcomponent

Description	Value
Off Road Bike Path(s)	0
Off Road Bike Path Width L/R	0.00 / 0.00
Bike Path Structural Spread Rate	0
Noise Barrier Wall Length	1,631.00
Noise Barrier Wall Begin Height	20.00
Noise Barrier Wall End Height	20.00

#### Pay Items

Pay item	Description	Quantity Unit	Unit Price	Extended Amount
521-72-40	SHLDR CONC BARRIER,38" OR 44" HEIGHT	1,237.00 LF	\$306.25	\$378,831.25
534-72-101	SOUND/NOISE BARRIER-INC FOUNDATION, PERM	32,620.00 SF	\$40.65	\$1,326,003.00

#### Roadway Component Total

\$4,078,128.91

### SHOULDER COMPONENT

#### User Input Data

Description	Value
Total Outside Shoulder Width L/R	12.00 / 12.00
Total Outside Shoulder Perf. Turf Width L/R	0.00 / 0.00
Paved Outside Shoulder Width L/R	12.00 / 12.00
Structural Spread Rate	220
Friction Course Spread Rate	165
Total Width (T) / 8" Overlap (O)	T
Rumble Strips i; ½No. of Sides	2

#### Pay Items

Pay item	Description	Quantity Unit	Unit Price	Extended Amount
285-705	OPTIONAL BASE,BASE GROUP 05	17,649.98 SY	\$40.53	\$715,353.69
334-1-53	SUPERPAVE ASPH CONC, TRAF C, PG76-22	1,889.54 TN	\$127.05	\$240,066.06
337-7-83	ASPH CONC FC,TRAFFIC C,FC- 12.5,PG 76-22	1,417.15 TN	\$122.75	\$173,955.16
546-72-1	GROUND-IN RUMBLE STRIPS, 16"	2.44 GM	\$881.71	\$2,151.37

#### X-Items

Pay item	Description	Quantity Unit	Unit Price	Extended Amount
521-8-7	CONC BARRIER, W/JUNCT SL, 36 SS	452.00 LF	\$303.07	\$136,987.64

#### Erosion Control

**Pay Items**

Pay item	Description	Quantity	Unit	Unit Price	Extended Amount
104-10-3	SEDIMENT BARRIER	16,748.16	LF	\$1.20	\$20,097.79
104-11	FLOATING TURBIDITY BARRIER	305.00	LF	\$9.49	\$2,894.45
104-12	STAKED TURBIDITY BARRIER- NYL REINF PVC	305.00	LF	\$4.44	\$1,354.20
104-15	SOIL TRACKING PREVENTION DEVICE	2.00	EA	\$2,988.11	\$5,976.22
107-1	LITTER REMOVAL	14.79	AC	\$20.76	\$307.04
107-2	MOWING	14.79	AC	\$46.89	\$693.50
<b>Shoulder Component Total</b>					<b>\$1,299,837.12</b>

**DRAINAGE COMPONENT****Pay Items**

Pay item	Description	Quantity	Unit	Unit Price	Extended Amount
430-174-124	PIPE CULV, OPT MATL, ROUND,24"SD	976.00	LF	\$126.21	\$123,180.96
430-175-136	PIPE CULV, OPT MATL, ROUND, 36"S/CD	208.00	LF	\$342.26	\$71,190.08
430-984-129	MITERED END SECT, OPTIONAL RD, 24" SD	49.00	EA	\$2,253.96	\$110,444.04
570-1-1	PERFORMANCE TURF	858.88	SY	\$3.19	\$2,739.83
<b>Drainage Component Total</b>					<b>\$307,554.91</b>

**SIGNING COMPONENT****Pay Items**

Pay item	Description	Quantity	Unit	Unit Price	Extended Amount
700-1-11	SINGLE POST SIGN, F&I GM, <12 SF	3.00	AS	\$380.22	\$1,140.66
700-1-12	SINGLE POST SIGN, F&I GM, 12- 20 SF	25.00	AS	\$1,503.18	\$37,579.50
700-2-14	MULTI- POST SIGN, F&I GM, 31-50 SF	3.00	AS	\$5,637.01	\$16,911.03
<b>Signing Component Total</b>					<b>\$55,631.19</b>

**INTELLIGENT TRAFFIC SYSTEM (ITS) COMPONENT****Description of Work**

General ITS per LF of roadway.

**EX-Items**

Pay item	Description	Quantity	Unit	Unit Price	Extended Amount
000-000	GENERAL ITS	7,218.00	LF	\$70.00	\$505,260.00
<b>Comment:</b> General ITS per LF of roadway.					
<b>Intelligent Traffic System (ITS) Component Total</b>					<b>\$505,260.00</b>

**LIGHTING COMPONENT****Rural Lighting Subcomponent**

Description

Value

Multiplier (Number of Poles)

34

**Pay Items**

Pay item	Description	Quantity	Unit	Unit Price	Extended Amount
630-2-11	CONDUIT, F& I, OPEN TRENCH	6,800.00	LF	\$9.76	\$66,368.00
635-2-11	PULL & SPLICE BOX, F&I, 13" x 24"	34.00	EA	\$767.98	\$26,111.32
715-1-13	LIGHTING CONDUCTORS, F&I, INSUL, NO.4-2	20,400.00	LF	\$2.62	\$53,448.00
715-4-14	LIGHT POLE COMPLETE, F&I-STD, 45'	34.00	EA	\$7,063.23	\$240,149.82
715-500-1	POLE CABLE DIST SYS, CONVENTIONAL	34.00	EA	\$621.64	\$21,135.76
<b>Subcomponent Total</b>					<b>\$407,212.90</b>
<b>Lighting Component Total</b>					<b>\$407,212.90</b>

**LANDSCAPING COMPONENT****User Input Data**

Description	Value
Cost %	2.00
Component Detail	N

**Landscaping Component Total** **\$113,710.42**

**BRIDGES COMPONENT****Bridge R-D2\_1**

Description	Value
Estimate Type	SF Estimate
Primary Estimate	YES
Length (LF)	898.00
Width (LF)	49.00
Type	High Level
Cost Factor	2.04
Structure No.	
Removal of Existing Structures area	0.00
Default Cost per SF	\$135.00
Factored Cost per SF	\$275.40
<b>Final Cost per SF</b>	<b>\$277.35</b>
<b>Basic Bridge Cost</b>	<b>\$12,118,150.80</b>

Description SR 538 RAMP D2: 2-LANE RAMP BRIDGE. WB I-4 GENERAL USE LANES TO SB SR 538.

**Bridge Pay Items**

Pay item	Description	Quantity	Unit	Unit Price	Extended Amount
400-2-10	CONC CLASS II, APPROACH SLABS	108.89	CY	\$588.22	\$64,051.28
415-1-9	REINF STEEL- APPROACH SLABS	19,055.75	LB	\$1.14	\$21,723.56
<b>Bridge R-D2_1 Total</b>					<b>\$12,203,925.64</b>

**Bridge R-D2\_2**

Description	Value
Estimate Type	SF Estimate
Primary Estimate	YES
Length (LF)	1,267.00
Width (LF)	61.00



Type	High Level
Cost Factor	2.04
Structure No.	
Removal of Existing Structures area	0.00
Default Cost per SF	\$135.00
Factored Cost per SF	\$275.40
<b>Final Cost per SF</b>	<b>\$276.78</b>
<b>Basic Bridge Cost</b>	<b>\$21,284,839.80</b>

Description SR 538 RAMP D2: 3-LANE RAMP BRIDGE. WB I-4 GENERAL USE LANES TO SB SR 538.

**Bridge Pay Items**

Pay item	Description	Quantity Unit	Unit Price	Extended Amount
400-2-10	CONC CLASS II, APPROACH SLABS	135.56 CY	\$588.22	\$79,739.10
415-1-9	REINF STEEL- APPROACH SLABS	23,723.00 LB	\$1.14	\$27,044.22
<b>Bridge R-D2_2 Total</b>				<b>\$21,391,623.12</b>
<b>Bridges Component Total</b>				<b>\$33,595,548.76</b>

**RETAINING WALLS COMPONENT**

**Retaining Wall 1**

Description	Value
Length	522.00
Begin height	17.50
End Height	17.50
Multiplier	2

**Pay Items**

Pay item	Description	Quantity Unit	Unit Price	Extended Amount
548-12	RET WALL SYSTEM, PERM, EX BARRIER	18,270.00 SF	\$36.17	\$660,825.90
<b>Retaining Walls Component Total</b>				<b>\$660,825.90</b>

**Sequence 25 Total** \$46,910,489.32

Sequence: 26 NUR - New Construction, Undivided, Rural

Net Length: 0.290 MI  
1,531 LF

Description: SR 429 Ramp D3: 1-Lane Ramp. WB I-4 General Use Lanes to NB SR 429 C-D Road.

### EARTHWORK COMPONENT

#### User Input Data

Description	Value
Standard Clearing and Grubbing Limits L/R	100.00 / 100.00
Incidental Clearing and Grubbing Area	0.00
Alignment Number	1
Distance	0.290
Top of Structural Course For Begin Section	117.50
Top of Structural Course For End Section	117.50
Horizontal Elevation For Begin Section	100.00
Horizontal Elevation For End Section	100.00
Front Slope L/R	6 to 1 / 6 to 1
Outside Shoulder Cross Slope L/R	5.00 % / 6.00 %
Roadway Cross Slope L/R	2.00 % / 2.00 %

#### Pay Items

Pay item	Description	Quantity	Unit	Unit Price	Extended Amount
110-1-1	CLEARING & GRUBBING	7.03	AC	\$21,000.00	\$147,630.00
120-6	EMBANKMENT	67,575.26	CY	\$20.88	\$1,410,971.43
<b>Earthwork Component Total</b>					<b>\$1,558,601.43</b>

### ROADWAY COMPONENT

#### User Input Data

Description	Value
Number of Lanes	1
Roadway Pavement Width L/R	0.00 / 15.00
Structural Spread Rate	440
Friction Course Spread Rate	165

#### Pay Items

Pay item	Description	Quantity	Unit	Unit Price	Extended Amount
160-4	TYPE B STABILIZATION	4,593.60	SY	\$11.66	\$53,561.38
285-712	OPTIONAL BASE,BASE GROUP 12	2,608.14	SY	\$73.16	\$190,811.52
334-1-53	SUPERPAVE ASPH CONC, TRAF C, PG76-22	561.44	TN	\$127.05	\$71,330.95
337-7-83	ASPH CONC FC,TRAFFIC C,FC-12.5,PG 76-22	210.54	TN	\$122.75	\$25,843.78

#### Pavement Marking Subcomponent

Description	Value
Include Thermo/Tape/Other	Y
Pavement Type	Asphalt
Solid Stripe No. of Paint Applications	1
Solid Stripe No. of Stripes	2
Skip Stripe No. of Paint Applications	1
Skip Stripe No. of Stripes	0

#### Pay Items

Pay item	Description	Quantity	Unit	Unit Price	Extended Amount
----------	-------------	----------	------	------------	-----------------

710-11-101	PAINTED PAVT MARK,STD,WHITE,SOLID,6"	0.58 GM	\$1,080.33	\$626.59
711-15-201	THERMOPLASTIC, STD- OP,YELLOW, SOLID, 6"	0.58 GM	\$4,988.35	\$2,893.24
711-16-101	THERMOPLASTIC, STD-OTH, WHITE, SOLID, 6"	0.58 GM	\$3,986.79	\$2,312.34

#### Peripherals Subcomponent

Description	Value
Off Road Bike Path(s)	0
Off Road Bike Path Width L/R	0.00 / 0.00
Bike Path Structural Spread Rate	0
Noise Barrier Wall Length	0.00
Noise Barrier Wall Begin Height	0.00
Noise Barrier Wall End Height	0.00

#### Roadway Component Total

\$347,379.81

### SHOULDER COMPONENT

#### User Input Data

Description	Value
Total Outside Shoulder Width L/R	6.00 / 6.00
Total Outside Shoulder Perf. Turf Width L/R	0.00 / 0.00
Paved Outside Shoulder Width L/R	6.00 / 6.00
Structural Spread Rate	220
Friction Course Spread Rate	165
Total Width (T) / 8" Overlap (O)	T
Rumble Strips $i_c$ 1/2 No. of Sides	2

#### Pay Items

Pay item	Description	Quantity	Unit	Unit Price	Extended Amount
285-705	OPTIONAL BASE,BASE GROUP 05	2,153.89	SY	\$40.53	\$87,297.16
334-1-53	SUPERPAVE ASPH CONC, TRAF C, PG76-22	224.58	TN	\$127.05	\$28,532.89
337-7-83	ASPH CONC FC,TRAFFIC C,FC- 12.5,PG 76-22	168.43	TN	\$122.75	\$20,674.78
546-72-1	GROUND-IN RUMBLE STRIPS, 16"	0.58	GM	\$881.71	\$511.39

#### Erosion Control

#### Pay Items

Pay item	Description	Quantity	Unit	Unit Price	Extended Amount
104-10-3	SEDIMENT BARRIER	3,981.12	LF	\$1.20	\$4,777.34
104-11	FLOATING TURBIDITY BARRIER	72.50	LF	\$9.49	\$688.02
104-12	STAKED TURBIDITY BARRIER- NYL REINF PVC	72.50	LF	\$4.44	\$321.90
104-15	SOIL TRACKING PREVENTION DEVICE	1.00	EA	\$2,988.11	\$2,988.11
107-1	LITTER REMOVAL	3.51	AC	\$20.76	\$72.87
107-2	MOWING	3.51	AC	\$46.89	\$164.58

#### Shoulder Component Total

\$146,029.05

### DRAINAGE COMPONENT

#### Pay Items

Pay item	Description	Quantity	Unit	Unit Price	Extended Amount
----------	-------------	----------	------	------------	-----------------

430-174-124	PIPE CULV, OPT MATL, ROUND,24"SD	232.00 LF	\$126.21	\$29,280.72
430-175-136	PIPE CULV, OPT MATL, ROUND, 36"S/CD	48.00 LF	\$342.26	\$16,428.48
430-984-129	MITERED END SECT, OPTIONAL RD, 24" SD	12.00 EA	\$2,253.96	\$27,047.52
570-1-1	PERFORMANCE TURF	204.16 SY	\$3.19	\$651.27
<b>Drainage Component Total</b>				<b>\$73,407.99</b>

### SIGNING COMPONENT

#### Pay Items

Pay item	Description	Quantity	Unit	Unit Price	Extended Amount
700-1-11	SINGLE POST SIGN, F&I GM, <12 SF	1.00	AS	\$380.22	\$380.22
700-1-12	SINGLE POST SIGN, F&I GM, 12-20 SF	6.00	AS	\$1,503.18	\$9,019.08
700-2-14	MULTI- POST SIGN, F&I GM, 31-50 SF	1.00	AS	\$5,637.01	\$5,637.01
<b>Signing Component Total</b>					<b>\$15,036.31</b>

### INTELLIGENT TRAFFIC SYSTEM (ITS) COMPONENT

#### Description of Work

General ITS per LF of roadway.

#### EX-Items

Pay item	Description	Quantity	Unit	Unit Price	Extended Amount
000-000	GENERAL ITS	2,019.00	LF	\$70.00	\$141,330.00
<b>Comment:</b> General ITS per LF of roadway.					
<b>Intelligent Traffic System (ITS) Component Total</b>					<b>\$141,330.00</b>

### LIGHTING COMPONENT

#### Rural Lighting Subcomponent

Description	Value				
Multiplier (Number of Poles)	11				
Pay item	Description	Quantity	Unit	Unit Price	Extended Amount
630-2-11	CONDUIT, F& I, OPEN TRENCH	2,200.00	LF	\$9.76	\$21,472.00
635-2-11	PULL & SPLICE BOX, F&I, 13" x 24"	11.00	EA	\$767.98	\$8,447.78
715-1-13	LIGHTING CONDUCTORS, F&I, INSUL, NO.4-2	6,600.00	LF	\$2.62	\$17,292.00
715-4-14	LIGHT POLE COMPLETE, F&I- STD, 45'	11.00	EA	\$7,063.23	\$77,695.53
715-500-1	POLE CABLE DIST SYS, CONVENTIONAL	11.00	EA	\$621.64	\$6,838.04
<b>Subcomponent Total</b>					<b>\$131,745.35</b>
<b>Lighting Component Total</b>					<b>\$131,745.35</b>

### LANDSCAPING COMPONENT

**User Input Data**

**Description**

**Value**

Cost %

2.00

Component Detail

N

---

**Landscaping Component Total**

\$11,336.34

---

**Sequence 26 Total**

\$2,424,866.28

---

Sequence: 27 NUR - New Construction, Undivided, Rural

Net Length: 0.300 MI  
1,584 LF

Description: Sinclair Ramp A1: 1-Lane Ramp. SB SR 429 to Sinclair Road.

**EARTHWORK COMPONENT**

**User Input Data**

Description	Value
Standard Clearing and Grubbing Limits L/R	100.00 / 100.00
Incidental Clearing and Grubbing Area	0.00
Alignment Number	1
Distance	0.300
Top of Structural Course For Begin Section	117.50
Top of Structural Course For End Section	117.50
Horizontal Elevation For Begin Section	100.00
Horizontal Elevation For End Section	100.00
Front Slope L/R	6 to 1 / 6 to 1
Outside Shoulder Cross Slope L/R	5.00 % / 6.00 %
Roadway Cross Slope L/R	2.00 % / 2.00 %

**Pay Items**

Pay item	Description	Quantity	Unit	Unit Price	Extended Amount
110-1-1	CLEARING & GRUBBING	7.27	AC	\$21,000.00	\$152,670.00
120-6	EMBANKMENT	69,965.28	CY	\$20.88	\$1,460,875.05
<b>Earthwork Component Total</b>					<b>\$1,613,545.05</b>

**ROADWAY COMPONENT**

**User Input Data**

Description	Value
Number of Lanes	1
Roadway Pavement Width L/R	0.00 / 15.00
Structural Spread Rate	440
Friction Course Spread Rate	165

**Pay Items**

Pay item	Description	Quantity	Unit	Unit Price	Extended Amount
160-4	TYPE B STABILIZATION	4,752.00	SY	\$11.66	\$55,408.32
285-712	OPTIONAL BASE,BASE GROUP 12	2,698.08	SY	\$73.16	\$197,391.53
334-1-53	SUPERPAVE ASPH CONC, TRAF C, PG76-22	580.80	TN	\$127.05	\$73,790.64
337-7-83	ASPH CONC FC,TRAFFIC C,FC-12.5,PG 76-22	217.80	TN	\$122.75	\$26,734.95

**Pavement Marking Subcomponent**

Description	Value
Include Thermo/Tape/Other	Y
Pavement Type	Asphalt
Solid Stripe No. of Paint Applications	1
Solid Stripe No. of Stripes	2
Skip Stripe No. of Paint Applications	1
Skip Stripe No. of Stripes	0

**Pay Items**

Pay item	Description	Quantity	Unit	Unit Price	Extended Amount
----------	-------------	----------	------	------------	-----------------

710-11-101	PAINTED PAVT MARK,STD,WHITE,SOLID,6"	0.60 GM	\$1,080.33	\$648.20
711-15-201	THERMOPLASTIC, STD- OP,YELLOW, SOLID, 6"	0.60 GM	\$4,988.35	\$2,993.01
711-16-101	THERMOPLASTIC, STD-OTH, WHITE, SOLID, 6"	0.60 GM	\$3,986.79	\$2,392.07

#### Peripherals Subcomponent

Description	Value
Off Road Bike Path(s)	0
Off Road Bike Path Width L/R	0.00 / 0.00
Bike Path Structural Spread Rate	0
Noise Barrier Wall Length	0.00
Noise Barrier Wall Begin Height	0.00
Noise Barrier Wall End Height	0.00

#### Roadway Component Total

\$359,358.72

### SHOULDER COMPONENT

#### User Input Data

Description	Value
Total Outside Shoulder Width L/R	6.00 / 6.00
Total Outside Shoulder Perf. Turf Width L/R	4.00 / 2.00
Paved Outside Shoulder Width L/R	2.00 / 4.00
Structural Spread Rate	220
Friction Course Spread Rate	165
Total Width (T) / 8" Overlap (O)	T
Rumble Strips 1/2 No. of Sides	2

#### Pay Items

Pay item	Description	Quantity Unit	Unit Price	Extended Amount
285-705	OPTIONAL BASE,BASE GROUP 05	1,172.16 SY	\$40.53	\$47,507.64
334-1-53	SUPERPAVE ASPH CONC, TRAF C, PG76-22	116.16 TN	\$127.05	\$14,758.13
337-7-83	ASPH CONC FC,TRAFFIC C,FC- 12.5,PG 76-22	87.12 TN	\$122.75	\$10,693.98
546-72-1	GROUND-IN RUMBLE STRIPS, 16"	0.60 GM	\$881.71	\$529.03
570-1-1	PERFORMANCE TURF	1,056.00 SY	\$3.19	\$3,368.64

#### Erosion Control

#### Pay Items

Pay item	Description	Quantity Unit	Unit Price	Extended Amount
104-10-3	SEDIMENT BARRIER	4,118.40 LF	\$1.20	\$4,942.08
104-11	FLOATING TURBIDITY BARRIER	75.00 LF	\$9.49	\$711.75
104-12	STAKED TURBIDITY BARRIER- NYL REINF PVC	75.00 LF	\$4.44	\$333.00
104-15	SOIL TRACKING PREVENTION DEVICE	1.00 EA	\$2,988.11	\$2,988.11
107-1	LITTER REMOVAL	3.64 AC	\$20.76	\$75.57
107-2	MOWING	3.64 AC	\$46.89	\$170.68

#### Shoulder Component Total

\$86,078.61

### DRAINAGE COMPONENT

#### Pay Items



Pay item	Description	Quantity	Unit	Unit Price	Extended Amount
430-174-124	PIPE CULV, OPT MATL, ROUND,24"SD	240.00	LF	\$126.21	\$30,290.40
430-175-136	PIPE CULV, OPT MATL, ROUND, 36"S/CD	56.00	LF	\$342.26	\$19,166.56
430-984-129	MITERED END SECT, OPTIONAL RD, 24" SD	12.00	EA	\$2,253.96	\$27,047.52
570-1-1	PERFORMANCE TURF	211.20	SY	\$3.19	\$673.73
<b>Drainage Component Total</b>					<b>\$77,178.21</b>

#### SIGNING COMPONENT

Pay Items					
Pay item	Description	Quantity	Unit	Unit Price	Extended Amount
700-1-11	SINGLE POST SIGN, F&I GM, <12 SF	1.00	AS	\$380.22	\$380.22
700-1-12	SINGLE POST SIGN, F&I GM, 12-20 SF	6.00	AS	\$1,503.18	\$9,019.08
700-2-14	MULTI- POST SIGN, F&I GM, 31-50 SF	1.00	AS	\$5,637.01	\$5,637.01
<b>Signing Component Total</b>					<b>\$15,036.31</b>

#### INTELLIGENT TRAFFIC SYSTEM (ITS) COMPONENT

##### Description of Work

General ITS per LF of roadway.

##### EX-Items

Pay item	Description	Quantity	Unit	Unit Price	Extended Amount
000-000	GENERAL ITS	1,098.00	LF	\$70.00	\$76,860.00
<b>Comment:</b> General ITS per LF of roadway.					
<b>Intelligent Traffic System (ITS) Component Total</b>					<b>\$76,860.00</b>

#### LIGHTING COMPONENT

##### Rural Lighting Subcomponent

Description					Value
Multiplier (Number of Poles)					6
Pay Items					
Pay item	Description	Quantity	Unit	Unit Price	Extended Amount
630-2-11	CONDUIT, F& I, OPEN TRENCH	1,200.00	LF	\$9.76	\$11,712.00
635-2-11	PULL & SPLICE BOX, F&I, 13" x 24"	6.00	EA	\$767.98	\$4,607.88
715-1-13	LIGHTING CONDUCTORS, F&I, INSUL, NO.4-2	3,600.00	LF	\$2.62	\$9,432.00
715-4-14	LIGHT POLE COMPLETE, F&I-STD, 45'	6.00	EA	\$7,063.23	\$42,379.38
715-500-1	POLE CABLE DIST SYS, CONVENTIONAL	6.00	EA	\$621.64	\$3,729.84
<b>Subcomponent Total</b>					<b>\$71,861.10</b>
<b>Lighting Component Total</b>					<b>\$71,861.10</b>

**LANDSCAPING COMPONENT**

**User Input Data**

<b>Description</b>	<b>Value</b>
Cost %	2.00
Component Detail	N

---

<b>Landscaping Component Total</b>	<b>\$10,452.31</b>
------------------------------------	--------------------

---

<b>Sequence 27 Total</b>	<b>\$2,310,370.31</b>
--------------------------	-----------------------

---

Sequence: 28 NUR - New Construction, Undivided, Rural

Net Length: 0.058 MI  
306 LF

Description: Sinclair Ramp A1: 2-Lane Ramp. SB SR 429 to Sinclair Road.

### EARTHWORK COMPONENT

#### User Input Data

Description	Value
Standard Clearing and Grubbing Limits L/R	50.00 / 94.00
Incidental Clearing and Grubbing Area	0.00
Alignment Number	1
Distance	0.058
Top of Structural Course For Begin Section	125.00
Top of Structural Course For End Section	125.00
Horizontal Elevation For Begin Section	100.00
Horizontal Elevation For End Section	100.00
Front Slope L/R	6 to 1 / 6 to 1
Outside Shoulder Cross Slope L/R	5.00 % / 6.00 %
Roadway Cross Slope L/R	2.00 % / 2.00 %

#### Pay Items

Pay item	Description	Quantity	Unit	Unit Price	Extended Amount
110-1-1	CLEARING & GRUBBING	1.01	AC	\$21,000.00	\$21,210.00
120-6	EMBANKMENT	54,909.17	CY	\$20.88	\$1,146,503.47
<b>Earthwork Component Total</b>					<b>\$1,167,713.47</b>

### ROADWAY COMPONENT

#### User Input Data

Description	Value
Number of Lanes	3
Roadway Pavement Width L/R	18.00 / 18.00
Structural Spread Rate	440
Friction Course Spread Rate	165

#### Pay Items

Pay item	Description	Quantity	Unit	Unit Price	Extended Amount
160-4	TYPE B STABILIZATION	1,973.55	SY	\$11.66	\$23,011.59
285-712	OPTIONAL BASE,BASE GROUP 12	1,247.42	SY	\$73.16	\$91,261.25
334-1-53	SUPERPAVE ASPH CONC, TRAF C, PG76-22	269.49	TN	\$127.05	\$34,238.70
337-7-83	ASPH CONC FC,TRAFFIC C,FC-12.5,PG 76-22	101.06	TN	\$122.75	\$12,405.12

#### Pavement Marking Subcomponent

Description	Value
Include Thermo/Tape/Other	Y
Pavement Type	Asphalt
Solid Stripe No. of Paint Applications	1
Solid Stripe No. of Stripes	2
Skip Stripe No. of Paint Applications	1
Skip Stripe No. of Stripes	2

#### Pay Items

Pay item	Description	Quantity	Unit	Unit Price	Extended Amount
----------	-------------	----------	------	------------	-----------------

706-1-1	RAISED PAVMT MARK, TYPE B W/O FINAL SURF	31.00 EA	\$3.58	\$110.98
710-11-101	PAINTED PAVT MARK,STD,WHITE,SOLID,6"	0.12 GM	\$1,080.33	\$129.64
710-11-231	PAINTED PAVT MARK,STD,YELLOW,SKIP,6"	0.12 GM	\$487.22	\$58.47
711-15-201	THERMOPLASTIC, STD- OP,YELLOW, SOLID, 6"	0.12 GM	\$4,988.35	\$598.60
711-16-101	THERMOPLASTIC, STD-OTH, WHITE, SOLID, 6"	0.12 GM	\$3,986.79	\$478.41
711-16-231	THERMOPLASTIC, STD-OTH, YELLOW, SKIP, 6"	0.12 GM	\$1,339.37	\$160.72

#### Peripherals Subcomponent

Description	Value
Off Road Bike Path(s)	0
Off Road Bike Path Width L/R	0.00 / 0.00
Bike Path Structural Spread Rate	0
Noise Barrier Wall Length	0.00
Noise Barrier Wall Begin Height	0.00
Noise Barrier Wall End Height	0.00

#### Roadway Component Total

\$162,453.48

### SHOULDER COMPONENT

#### User Input Data

Description	Value
Total Outside Shoulder Width L/R	10.00 / 12.00
Total Outside Shoulder Perf. Turf Width L/R	4.00 / 2.00
Paved Outside Shoulder Width L/R	6.00 / 10.00
Structural Spread Rate	220
Friction Course Spread Rate	165
Total Width (T) / 8" Overlap (O)	T
Rumble Strips $i_c$ 1/2 No. of Sides	2

#### Pay Items

Pay item	Description	Quantity	Unit	Unit Price	Extended Amount
285-705	OPTIONAL BASE,BASE GROUP 05	566.88	SY	\$40.53	\$22,975.65
334-1-53	SUPERPAVE ASPH CONC, TRAF C, PG76-22	59.89	TN	\$127.05	\$7,609.02
337-7-83	ASPH CONC FC,TRAFFIC C,FC- 12.5,PG 76-22	44.92	TN	\$122.75	\$5,513.93
546-72-1	GROUND-IN RUMBLE STRIPS, 16"	0.12	GM	\$881.71	\$105.81
570-1-1	PERFORMANCE TURF	204.16	SY	\$3.19	\$651.27

#### Erosion Control

#### Pay Items

Pay item	Description	Quantity	Unit	Unit Price	Extended Amount
104-10-3	SEDIMENT BARRIER	796.22	LF	\$1.20	\$955.46
104-11	FLOATING TURBIDITY BARRIER	14.50	LF	\$9.49	\$137.61
104-12	STAKED TURBIDITY BARRIER- NYL REINF PVC	14.50	LF	\$4.44	\$64.38
104-15	SOIL TRACKING PREVENTION DEVICE	1.00	EA	\$2,988.11	\$2,988.11
107-1	LITTER REMOVAL	0.70	AC	\$20.76	\$14.53
107-2	MOWING	0.70	AC	\$46.89	\$32.82

Shoulder Component Total

\$41,048.59

**DRAINAGE COMPONENT**

**Pay Items**

Pay item	Description	Quantity	Unit	Unit Price	Extended Amount
430-174-124	PIPE CULV, OPT MATL, ROUND,24"SD	48.00	LF	\$126.21	\$6,058.08
430-175-136	PIPE CULV, OPT MATL, ROUND, 36"S/CD	16.00	LF	\$342.26	\$5,476.16
430-984-129	MITERED END SECT, OPTIONAL RD, 24" SD	3.00	EA	\$2,253.96	\$6,761.88
570-1-1	PERFORMANCE TURF	40.83	SY	\$3.19	\$130.25
<b>Drainage Component Total</b>					<b>\$18,426.37</b>

**SIGNING COMPONENT**

**Pay Items**

Pay item	Description	Quantity	Unit	Unit Price	Extended Amount
700-1-11	SINGLE POST SIGN, F&I GM, <12 SF	1.00	AS	\$380.22	\$380.22
700-1-12	SINGLE POST SIGN, F&I GM, 12-20 SF	2.00	AS	\$1,503.18	\$3,006.36
700-2-14	MULTI- POST SIGN, F&I GM, 31-50 SF	1.00	AS	\$5,637.01	\$5,637.01
<b>Signing Component Total</b>					<b>\$9,023.59</b>

**INTELLIGENT TRAFFIC SYSTEM (ITS) COMPONENT**

**Description of Work**

General ITS per LF of roadway.

**EX-Items**

Pay item	Description	Quantity	Unit	Unit Price	Extended Amount
000-000	GENERAL ITS	306.00	LF	\$70.00	\$21,420.00
<b>Comment:</b> General ITS per LF of roadway.					
<b>Intelligent Traffic System (ITS) Component Total</b>					<b>\$21,420.00</b>

**LIGHTING COMPONENT**

**Rural Lighting Subcomponent**

**Description**

Multiplier (Number of Poles)

**Value**

2

**Pay Items**

Pay item	Description	Quantity	Unit	Unit Price	Extended Amount
630-2-11	CONDUIT, F& I, OPEN TRENCH	400.00	LF	\$9.76	\$3,904.00
635-2-11	PULL & SPLICE BOX, F&I, 13" x 24"	2.00	EA	\$767.98	\$1,535.96
715-1-13	LIGHTING CONDUCTORS, F&I, INSUL, NO.4-2	1,200.00	LF	\$2.62	\$3,144.00
715-4-14	LIGHT POLE COMPLETE, F&I-STD, 45'	2.00	EA	\$7,063.23	\$14,126.46
715-500-1	POLE CABLE DIST SYS, CONVENTIONAL	2.00	EA	\$621.64	\$1,243.28

**Subcomponent Total** \$23,953.70

**Lighting Component Total** \$23,953.70

---

**LANDSCAPING COMPONENT**

**User Input Data**

<b>Description</b>	<b>Value</b>
Cost %	2.00
Component Detail	N

**Landscaping Component Total** \$4,438.57

---

**Sequence 28 Total** \$1,448,477.77

---

Sequence: 29NUR - New Construction, Undivided, Rural

Net Length: 0.085 MI  
447 LF

Description: Sinclair Ramp B1: 2-Lane Ramp. Sinclair Rd to SB SR 429 C-D Road. Includes Toll Plaza.

### EARTHWORK COMPONENT

#### User Input Data

Description	Value
Standard Clearing and Grubbing Limits L/R	50.00 / 94.00
Incidental Clearing and Grubbing Area	0.00
Alignment Number	1
Distance	0.085
Top of Structural Course For Begin Section	125.00
Top of Structural Course For End Section	125.00
Horizontal Elevation For Begin Section	100.00
Horizontal Elevation For End Section	100.00
Front Slope L/R	6 to 1 / 6 to 1
Outside Shoulder Cross Slope L/R	5.00 % / 6.00 %
Roadway Cross Slope L/R	2.00 % / 2.00 %

#### Pay Items

Pay item	Description	Quantity	Unit	Unit Price	Extended Amount
110-1-1	CLEARING & GRUBBING	1.48	AC	\$21,000.00	\$31,080.00
120-6	EMBANKMENT	75,270.91	CY	\$20.88	\$1,571,656.60
<b>Earthwork Component Total</b>					<b>\$1,602,736.60</b>

### ROADWAY COMPONENT

#### User Input Data

Description	Value
Number of Lanes	2
Roadway Pavement Width L/R	12.00 / 12.00
Structural Spread Rate	440
Friction Course Spread Rate	165

#### Pay Items

Pay item	Description	Quantity	Unit	Unit Price	Extended Amount
160-4	TYPE B STABILIZATION	2,087.01	SY	\$11.66	\$24,334.54
285-712	OPTIONAL BASE,BASE GROUP 12	1,225.37	SY	\$73.16	\$89,648.07
334-1-53	SUPERPAVE ASPH CONC, TRAF C, PG76-22	262.37	TN	\$127.05	\$33,334.11
337-7-83	ASPH CONC FC,TRAFFIC C,FC-12.5,PG 76-22	98.39	TN	\$122.75	\$12,077.37

#### X-Items

Pay item	Description	Quantity	Unit	Unit Price	Extended Amount
521-1-11	MEDIAN CONC BARRIER, 38" HEIGHT	894.00	LF	\$316.17	\$282,655.98
<b>Comment:</b> For Toll Plaza					

#### Pavement Marking Subcomponent

Description	Value
Include Thermo/Tape/Other	Y
Pavement Type	Asphalt
Solid Stripe No. of Paint Applications	1



Solid Stripe No. of Stripes	2
Skip Stripe No. of Paint Applications	1
Skip Stripe No. of Stripes	1

**Pay Items**

Pay item	Description	Quantity Unit	Unit Price	Extended Amount
706-1-3	RAISED PAVMT MARK, TYPE B	11.00 EA	\$3.21	\$35.31
710-11-101	PAINTED PAVT MARK,STD,WHITE,SOLID,6"	0.17 GM	\$1,080.33	\$183.66
710-11-231	PAINTED PAVT MARK,STD,YELLOW,SKIP,6"	0.08 GM	\$487.22	\$38.98
711-15-201	THERMOPLASTIC, STD-OP,YELLOW, SOLID, 6"	0.17 GM	\$4,988.35	\$848.02
711-16-101	THERMOPLASTIC, STD-OTH, WHITE, SOLID, 6"	0.17 GM	\$3,986.79	\$677.75
711-16-231	THERMOPLASTIC, STD-OTH, YELLOW, SKIP, 6"	0.08 GM	\$1,339.37	\$107.15

**Peripherals Subcomponent**

Description	Value
Off Road Bike Path(s)	0
Off Road Bike Path Width L/R	0.00 / 0.00
Bike Path Structural Spread Rate	0
Noise Barrier Wall Length	0.00
Noise Barrier Wall Begin Height	0.00
Noise Barrier Wall End Height	0.00

**Roadway Component Total**

\$443,940.94

**SHOULDER COMPONENT**

**User Input Data**

Description	Value
Total Outside Shoulder Width L/R	6.00 / 12.00
Total Outside Shoulder Perf. Turf Width L/R	0.00 / 2.00
Paved Outside Shoulder Width L/R	6.00 / 10.00
Structural Spread Rate	220
Friction Course Spread Rate	165
Total Width (T) / 8" Overlap (O)	T
Rumble Strips 1/2 No. of Sides	2

**Pay Items**

Pay item	Description	Quantity Unit	Unit Price	Extended Amount
285-705	OPTIONAL BASE,BASE GROUP 05	827.85 SY	\$40.53	\$33,552.76
334-1-53	SUPERPAVE ASPH CONC, TRAF C, PG76-22	87.46 TN	\$127.05	\$11,111.79
337-7-83	ASPH CONC FC,TRAFFIC C,FC-12.5,PG 76-22	65.59 TN	\$122.75	\$8,051.17
546-72-1	GROUND-IN RUMBLE STRIPS, 16"	0.17 GM	\$881.71	\$149.89
570-1-1	PERFORMANCE TURF	99.38 SY	\$3.19	\$317.02

**Erosion Control**

**Pay Items**

Pay item	Description	Quantity Unit	Unit Price	Extended Amount
104-10-3	SEDIMENT BARRIER	1,162.76 LF	\$1.20	\$1,395.31
104-11	FLOATING TURBIDITY BARRIER	21.18 LF	\$9.49	\$201.00

104-12	STAKED TURBIDITY BARRIER- NYL REINF PVC	21.18 LF	\$4.44	\$94.04
104-15	SOIL TRACKING PREVENTION DEVICE	1.00 EA	\$2,988.11	\$2,988.11
107-1	LITTER REMOVAL	1.03 AC	\$20.76	\$21.38
107-2	MOWING	1.03 AC	\$46.89	\$48.30
<b>Shoulder Component Total</b>				<b>\$57,930.77</b>

**DRAINAGE COMPONENT**

**Pay Items**

Pay item	Description	Quantity Unit	Unit Price	Extended Amount
430-174-124	PIPE CULV, OPT MATL, ROUND,24"SD	72.00 LF	\$126.21	\$9,087.12
430-175-136	PIPE CULV, OPT MATL, ROUND, 36"S/CD	16.00 LF	\$342.26	\$5,476.16
430-984-129	MITERED END SECT, OPTIONAL RD, 24" SD	4.00 EA	\$2,253.96	\$9,015.84
570-1-1	PERFORMANCE TURF	59.63 SY	\$3.19	\$190.22
<b>Drainage Component Total</b>				<b>\$23,769.34</b>

**SIGNING COMPONENT**

**Pay Items**

Pay item	Description	Quantity Unit	Unit Price	Extended Amount
700-1-11	SINGLE POST SIGN, F&I GM, <12 SF	1.00 AS	\$380.22	\$380.22
700-1-12	SINGLE POST SIGN, F&I GM, 12- 20 SF	2.00 AS	\$1,503.18	\$3,006.36
700-2-14	MULTI- POST SIGN, F&I GM, 31-50 SF	1.00 AS	\$5,637.01	\$5,637.01
<b>Signing Component Total</b>				<b>\$9,023.59</b>

**INTELLIGENT TRAFFIC SYSTEM (ITS) COMPONENT**

**Description of Work**

General ITS per LF of roadway.

**EX-Items**

Pay item	Description	Quantity Unit	Unit Price	Extended Amount
000-000	GENERAL ITS	447.00 LF	\$70.00	\$31,290.00
<b>Comment:</b> General ITS per LF of roadway.				
<b>Intelligent Traffic System (ITS) Component Total</b>				<b>\$31,290.00</b>

**LIGHTING COMPONENT**

**Rural Lighting Subcomponent**

**Description**

Multiplier (Number of Poles)

**Value**

3

**Pay Items**

Pay item	Description	Quantity Unit	Unit Price	Extended Amount
630-2-11	CONDUIT, F& I, OPEN TRENCH	600.00 LF	\$9.76	\$5,856.00

635-2-11	PULL & SPLICE BOX, F&I, 13" x 24"	3.00 EA	\$767.98	\$2,303.94
715-1-13	LIGHTING CONDUCTORS, F&I, INSUL, NO.4-2	1,800.00 LF	\$2.62	\$4,716.00
715-4-14	LIGHT POLE COMPLETE, F&I-STD, 45'	3.00 EA	\$7,063.23	\$21,189.69
715-500-1	POLE CABLE DIST SYS, CONVENTIONAL	3.00 EA	\$621.64	\$1,864.92
	<b>Subcomponent Total</b>			\$35,930.55
	<b>Lighting Component Total</b>			\$35,930.55

---

**LANDSCAPING COMPONENT**

**User Input Data**

Description	Value
Cost %	2.00
Component Detail	N

**Landscaping Component Total** \$10,512.82

---

**ARCHITECTURAL COMPONENT**

**X-Items**

Pay item	Description	Quantity Unit	Unit Price	Extended Amount
735-74	TOLL PLAZA, SINGLE LOCATION	1.00 LS	\$2,977,187.94	\$2,977,187.94

**Architectural Component Total** \$2,977,187.94

---

**Sequence 29 Total** \$5,192,322.55

---

Sequence: 30 NUR - New Construction, Undivided, Rural

Net Length: 0.160 MI  
845 LF

Description: Sinclair Ramp B1: 1-Lane Ramp. Sinclair Rd to SB SR 429 C-D Road. Includes Barrier Wall.

### EARTHWORK COMPONENT

#### User Input Data

Description	Value
Standard Clearing and Grubbing Limits L/R	70.00 / 100.00
Incidental Clearing and Grubbing Area	0.00
Alignment Number	1
Distance	0.160
Top of Structural Course For Begin Section	105.00
Top of Structural Course For End Section	105.00
Horizontal Elevation For Begin Section	100.00
Horizontal Elevation For End Section	100.00
Front Slope L/R	6 to 1 / 6 to 1
Outside Shoulder Cross Slope L/R	5.00 % / 6.00 %
Roadway Cross Slope L/R	2.00 % / 2.00 %

#### Pay Items

Pay item	Description	Quantity	Unit	Unit Price	Extended Amount
110-1-1	CLEARING & GRUBBING	3.30	AC	\$21,000.00	\$69,300.00
120-6	EMBANKMENT	4,654.54	CY	\$20.88	\$97,186.80
<b>Earthwork Component Total</b>					<b>\$166,486.80</b>

### ROADWAY COMPONENT

#### User Input Data

Description	Value
Number of Lanes	1
Roadway Pavement Width L/R	0.00 / 15.00
Structural Spread Rate	440
Friction Course Spread Rate	165

#### Pay Items

Pay item	Description	Quantity	Unit	Unit Price	Extended Amount
160-4	TYPE B STABILIZATION	3,473.07	SY	\$11.66	\$40,496.00
285-712	OPTIONAL BASE,BASE GROUP 12	1,438.98	SY	\$73.16	\$105,275.78
334-1-53	SUPERPAVE ASPH CONC, TRAF C, PG76-22	309.76	TN	\$127.05	\$39,355.01
337-7-83	ASPH CONC FC,TRAFFIC C,FC-12.5,PG 76-22	116.16	TN	\$122.75	\$14,258.64

#### Pavement Marking Subcomponent

Description	Value
Include Thermo/Tape/Other	Y
Pavement Type	Asphalt
Solid Stripe No. of Paint Applications	1
Solid Stripe No. of Stripes	2
Skip Stripe No. of Paint Applications	1
Skip Stripe No. of Stripes	0

#### Pay Items

Pay item	Description	Quantity	Unit	Unit Price	Extended Amount
----------	-------------	----------	------	------------	-----------------

710-11-101	PAINTED PAVT MARK,STD,WHITE,SOLID,6"	0.32 GM	\$1,080.33	\$345.71
711-15-201	THERMOPLASTIC, STD- OP,YELLOW, SOLID, 6"	0.32 GM	\$4,988.35	\$1,596.27
711-16-101	THERMOPLASTIC, STD-OTH, WHITE, SOLID, 6"	0.32 GM	\$3,986.79	\$1,275.77
<b>Roadway Component Total</b>				<b>\$202,603.18</b>

### SHOULDER COMPONENT

#### User Input Data

Description	Value
Total Outside Shoulder Width L/R	10.00 / 12.00
Total Outside Shoulder Perf. Turf Width L/R	4.00 / 2.00
Paved Outside Shoulder Width L/R	6.00 / 10.00
Structural Spread Rate	220
Friction Course Spread Rate	165
Total Width (T) / 8" Overlap (O)	T
Rumble Strips i <sub>l</sub> ½No. of Sides	2

#### Pay Items

Pay item	Description	Quantity	Unit	Unit Price	Extended Amount
285-705	OPTIONAL BASE,BASE GROUP 05	1,563.82	SY	\$40.53	\$63,381.62
334-1-53	SUPERPAVE ASPH CONC, TRAF C, PG76-22	165.21	TN	\$127.05	\$20,989.93
337-7-83	ASPH CONC FC,TRAFFIC C,FC- 12.5,PG 76-22	123.90	TN	\$122.75	\$15,208.72
546-72-1	GROUND-IN RUMBLE STRIPS, 16"	0.32	GM	\$881.71	\$282.15
570-1-1	PERFORMANCE TURF	563.20	SY	\$3.19	\$1,796.61

#### Erosion Control

#### Pay Items

Pay item	Description	Quantity	Unit	Unit Price	Extended Amount
104-10-3	SEDIMENT BARRIER	2,196.48	LF	\$1.20	\$2,635.78
104-11	FLOATING TURBIDITY BARRIER	40.00	LF	\$9.49	\$379.60
104-12	STAKED TURBIDITY BARRIER- NYL REINF PVC	40.00	LF	\$4.44	\$177.60
104-15	SOIL TRACKING PREVENTION DEVICE	1.00	EA	\$2,988.11	\$2,988.11
107-1	LITTER REMOVAL	1.94	AC	\$20.76	\$40.27
107-2	MOWING	1.94	AC	\$46.89	\$90.97

**Shoulder Component Total** **\$107,971.37**

### DRAINAGE COMPONENT

#### Pay Items

Pay item	Description	Quantity	Unit	Unit Price	Extended Amount
430-174-124	PIPE CULV, OPT MATL, ROUND,24"SD	128.00	LF	\$126.21	\$16,154.88
430-175-136	PIPE CULV, OPT MATL, ROUND, 36"S/CD	32.00	LF	\$342.26	\$10,952.32
430-984-129	MITERED END SECT, OPTIONAL RD, 24" SD	7.00	EA	\$2,253.96	\$15,777.72
570-1-1	PERFORMANCE TURF	112.64	SY	\$3.19	\$359.32

**Drainage Component Total**

\$43,244.24

**SIGNING COMPONENT**

**Pay Items**

<b>Pay item</b>	<b>Description</b>	<b>Quantity</b>	<b>Unit</b>	<b>Unit Price</b>	<b>Extended Amount</b>
700-1-11	SINGLE POST SIGN, F&I GM, <12 SF	1.00	AS	\$380.22	\$380.22
700-1-12	SINGLE POST SIGN, F&I GM, 12-20 SF	4.00	AS	\$1,503.18	\$6,012.72
700-2-14	MULTI- POST SIGN, F&I GM, 31-50 SF	1.00	AS	\$5,637.01	\$5,637.01
<b>Signing Component Total</b>					<b>\$12,029.95</b>

**INTELLIGENT TRAFFIC SYSTEM (ITS) COMPONENT**

**Description of Work**

General ITS per LF of roadway.

**EX-Items**

<b>Pay item</b>	<b>Description</b>	<b>Quantity</b>	<b>Unit</b>	<b>Unit Price</b>	<b>Extended Amount</b>
000-000	GENERAL ITS <b>Comment:</b> General ITS per LF of roadway.	1,597.00	LF	\$70.00	\$111,790.00
<b>Intelligent Traffic System (ITS) Component Total</b>					<b>\$111,790.00</b>

**LIGHTING COMPONENT**

**Rural Lighting Subcomponent**

**Description**

Multiplier (Number of Poles)

**Value**

9

**Pay Items**

<b>Pay item</b>	<b>Description</b>	<b>Quantity</b>	<b>Unit</b>	<b>Unit Price</b>	<b>Extended Amount</b>
630-2-11	CONDUIT, F& I, OPEN TRENCH	1,800.00	LF	\$9.76	\$17,568.00
635-2-11	PULL & SPLICE BOX, F&I, 13" x 24"	9.00	EA	\$767.98	\$6,911.82
715-1-13	LIGHTING CONDUCTORS, F&I, INSUL, NO.4-2	5,400.00	LF	\$2.62	\$14,148.00
715-4-14	LIGHT POLE COMPLETE, F&I-STD, 45'	9.00	EA	\$7,063.23	\$63,569.07
715-500-1	POLE CABLE DIST SYS, CONVENTIONAL	9.00	EA	\$621.64	\$5,594.76
<b>Subcomponent Total</b>					<b>\$107,791.65</b>
<b>Lighting Component Total</b>					<b>\$107,791.65</b>

**Sequence 30 Total**

\$751,917.19

Sequence: 31 NUR - New Construction, Undivided, Rural

Net Length: 0.183 MI  
965 LF

Description: Sinclair Ramp C1: 2-Lane Ramp. NB SR 429 Off Ramp to Sinclair Road. Includes Toll Plaza.

### EARTHWORK COMPONENT

#### User Input Data

Description	Value
Standard Clearing and Grubbing Limits L/R	50.00 / 100.00
Incidental Clearing and Grubbing Area	0.00
Alignment Number	1
Distance	0.180
Top of Structural Course For Begin Section	125.00
Top of Structural Course For End Section	125.00
Horizontal Elevation For Begin Section	100.00
Horizontal Elevation For End Section	100.00
Front Slope L/R	6 to 1 / 6 to 1
Outside Shoulder Cross Slope L/R	5.00 % / 6.00 %
Roadway Cross Slope L/R	2.00 % / 2.00 %

#### Pay Items

Pay item	Description	Quantity	Unit	Unit Price	Extended Amount
110-1-1	CLEARING & GRUBBING	3.33	AC	\$21,000.00	\$69,930.00
120-6	EMBANKMENT	157,291.90	CY	\$20.88	\$3,284,254.87
<b>Earthwork Component Total</b>					<b>\$3,354,184.87</b>

### ROADWAY COMPONENT

#### User Input Data

Description	Value
Number of Lanes	2
Roadway Pavement Width L/R	12.00 / 12.00
Structural Spread Rate	440
Friction Course Spread Rate	165

#### Pay Items

Pay item	Description	Quantity	Unit	Unit Price	Extended Amount
160-4	TYPE B STABILIZATION	4,075.22	SY	\$11.66	\$47,517.07
285-712	OPTIONAL BASE,BASE GROUP 12	2,644.60	SY	\$73.16	\$193,478.94
334-1-53	SUPERPAVE ASPH CONC, TRAF C, PG76-22	566.24	TN	\$127.05	\$71,940.79
337-7-83	ASPH CONC FC,TRAFFIC C,FC-12.5,PG 76-22	212.34	TN	\$122.75	\$26,064.74

#### X-Items

Pay item	Description	Quantity	Unit	Unit Price	Extended Amount
521-1-11	MEDIAN CONC BARRIER, 38" HEIGHT	570.00	LF	\$316.17	\$180,216.90

#### Pavement Marking Subcomponent

Description	Value
Include Thermo/Tape/Other	Y
Pavement Type	Asphalt
Solid Stripe No. of Paint Applications	1
Solid Stripe No. of Stripes	2



Skip Stripe No. of Paint Applications	1
Skip Stripe No. of Stripes	1

**Pay Items**

Pay item	Description	Quantity Unit	Unit Price	Extended Amount
706-1-3	RAISED PAVMT MARK, TYPE B	25.00 EA	\$3.21	\$80.25
710-11-101	PAINTED PAVT MARK,STD,WHITE,SOLID,6"	0.37 GM	\$1,080.33	\$399.72
710-11-231	PAINTED PAVT MARK,STD,YELLOW,SKIP,6"	0.18 GM	\$487.22	\$87.70
711-15-201	THERMOPLASTIC, STD-OP,YELLOW, SOLID, 6"	0.37 GM	\$4,988.35	\$1,845.69
711-16-101	THERMOPLASTIC, STD-OTH, WHITE, SOLID, 6"	0.37 GM	\$3,986.79	\$1,475.11
711-16-231	THERMOPLASTIC, STD-OTH, YELLOW, SKIP, 6"	0.18 GM	\$1,339.37	\$241.09
<b>Roadway Component Total</b>				<b>\$523,348.00</b>

**SHOULDER COMPONENT**

**User Input Data**

Description	Value
Total Outside Shoulder Width L/R	6.00 / 8.00
Total Outside Shoulder Perf. Turf Width L/R	0.00 / 2.00
Paved Outside Shoulder Width L/R	6.00 / 6.00
Structural Spread Rate	220
Friction Course Spread Rate	165
Total Width (T) / 8" Overlap (O)	T
Rumble Strips 1/2 No. of Sides	2

**Pay Items**

Pay item	Description	Quantity Unit	Unit Price	Extended Amount
285-705	OPTIONAL BASE,BASE GROUP 05	1,357.69 SY	\$40.53	\$55,027.18
334-1-53	SUPERPAVE ASPH CONC, TRAF C, PG76-22	141.56 TN	\$127.05	\$17,985.20
337-7-83	ASPH CONC FC,TRAFFIC C,FC-12.5,PG 76-22	106.17 TN	\$122.75	\$13,032.37
546-72-1	GROUND-IN RUMBLE STRIPS, 16"	0.37 GM	\$881.71	\$326.23
570-1-1	PERFORMANCE TURF	214.49 SY	\$3.19	\$684.22

**Erosion Control**

**Pay Items**

Pay item	Description	Quantity Unit	Unit Price	Extended Amount
104-10-3	SEDIMENT BARRIER	2,509.48 LF	\$1.20	\$3,011.38
104-11	FLOATING TURBIDITY BARRIER	45.70 LF	\$9.49	\$433.69
104-12	STAKED TURBIDITY BARRIER-NYL REINF PVC	45.70 LF	\$4.44	\$202.91
104-15	SOIL TRACKING PREVENTION DEVICE	1.00 EA	\$2,988.11	\$2,988.11
107-1	LITTER REMOVAL	2.22 AC	\$20.76	\$46.09
107-2	MOWING	2.22 AC	\$46.89	\$104.10
<b>Shoulder Component Total</b>				<b>\$93,841.48</b>

**DRAINAGE COMPONENT**

**Pay Items**

Pay item	Description	Quantity Unit	Unit Price	Extended Amount
430-174-124	PIPE CULV, OPT MATL, ROUND,24"SD	152.00 LF	\$126.21	\$19,183.92
430-175-136	PIPE CULV, OPT MATL, ROUND, 36"S/CD	32.00 LF	\$342.26	\$10,952.32
430-984-129	MITERED END SECT, OPTIONAL RD, 24" SD	8.00 EA	\$2,253.96	\$18,031.68
570-1-1	PERFORMANCE TURF	128.69 SY	\$3.19	\$410.52

**X-Items**

Pay item	Description	Quantity Unit	Unit Price	Extended Amount
425-1-921	INLETS, ADJACENT BARRIER, <=10'	2.00 EA	\$5,906.88	\$11,813.76

**Drainage Component Total** \$60,392.20

---

**SIGNING COMPONENT**

**Pay Items**

Pay item	Description	Quantity Unit	Unit Price	Extended Amount
700-1-11	SINGLE POST SIGN, F&I GM, <12 SF	1.00 AS	\$380.22	\$380.22
700-1-12	SINGLE POST SIGN, F&I GM, 12-20 SF	4.00 AS	\$1,503.18	\$6,012.72
700-2-14	MULTI- POST SIGN, F&I GM, 31-50 SF	1.00 AS	\$5,637.01	\$5,637.01

**X-Items**

Pay item	Description	Quantity Unit	Unit Price	Extended Amount
700-4-114	OH STATIC SIGN STR, F&I, C 41-50 FT	1.00 EA	\$94,981.18	\$94,981.18

**Signing Component Total** \$107,011.13

---

**INTELLIGENT TRAFFIC SYSTEM (ITS) COMPONENT**

**Description of Work**

General ITS per LF of roadway.

**EX-Items**

Pay item	Description	Quantity Unit	Unit Price	Extended Amount
000-000	GENERAL ITS	965.00 LF	\$70.00	\$67,550.00

**Comment:** General ITS per LF of roadway.

**Intelligent Traffic System (ITS) Component Total** \$67,550.00

---

**LIGHTING COMPONENT**

**Rural Lighting Subcomponent**

Description	Value
Multiplier (Number of Poles)	6

**Pay Items**

Pay item	Description	Quantity Unit	Unit Price	Extended Amount
630-2-11	CONDUIT, F& I, OPEN TRENCH	1,200.00 LF	\$9.76	\$11,712.00

635-2-11	PULL & SPLICE BOX, F&I, 13" x 24"	6.00 EA	\$767.98	\$4,607.88
715-1-13	LIGHTING CONDUCTORS, F&I, INSUL, NO.4-2	3,600.00 LF	\$2.62	\$9,432.00
715-4-14	LIGHT POLE COMPLETE, F&I-STD, 45'	6.00 EA	\$7,063.23	\$42,379.38
715-500-1	POLE CABLE DIST SYS, CONVENTIONAL	6.00 EA	\$621.64	\$3,729.84
	<b>Subcomponent Total</b>			\$71,861.10
	<b>Lighting Component Total</b>			\$71,861.10

---

**LANDSCAPING COMPONENT**

**User Input Data**

Description	Value
Cost %	2.00
Component Detail	N

**Landscaping Component Total** \$13,551.63

---

**ARCHITECTURAL COMPONENT**

**X-Items**

Pay item	Description	Quantity Unit	Unit Price	Extended Amount
735-74	TOLL PLAZA, SINGLE LOCATION	1.00 LS	\$2,977,187.94	\$2,977,187.94
	<b>Architectural Component Total</b>			\$2,977,187.94

---

**Sequence 31 Total** \$7,268,928.35

---

Sequence: 32 NUR - New Construction, Undivided, Rural

Net Length: 0.140 MI  
739 LF

Description: Sinclair Ramp C1: 1-Lane Ramp. NB SR 429 C-D Road Off Ramp to Sinclair Road.

### EARTHWORK COMPONENT

#### User Input Data

Description	Value
Standard Clearing and Grubbing Limits L/R	70.00 / 100.00
Incidental Clearing and Grubbing Area	0.00
Alignment Number	1
Distance	0.140
Top of Structural Course For Begin Section	105.00
Top of Structural Course For End Section	105.00
Horizontal Elevation For Begin Section	100.00
Horizontal Elevation For End Section	100.00
Front Slope L/R	6 to 1 / 6 to 1
Outside Shoulder Cross Slope L/R	5.00 % / 6.00 %
Roadway Cross Slope L/R	2.00 % / 2.00 %

#### Pay Items

Pay item	Description	Quantity	Unit	Unit Price	Extended Amount
110-1-1	CLEARING & GRUBBING	2.88	AC	\$21,000.00	\$60,480.00
120-6	EMBANKMENT	4,072.72	CY	\$20.88	\$85,038.39
<b>Earthwork Component Total</b>					<b>\$145,518.39</b>

### ROADWAY COMPONENT

#### User Input Data

Description	Value
Number of Lanes	1
Roadway Pavement Width L/R	0.00 / 15.00
Structural Spread Rate	440
Friction Course Spread Rate	165

#### Pay Items

Pay item	Description	Quantity	Unit	Unit Price	Extended Amount
160-4	TYPE B STABILIZATION	3,038.93	SY	\$11.66	\$35,433.92
285-712	OPTIONAL BASE,BASE GROUP 12	1,259.10	SY	\$73.16	\$92,115.76
334-1-53	SUPERPAVE ASPH CONC, TRAF C, PG76-22	271.04	TN	\$127.05	\$34,435.63
337-7-83	ASPH CONC FC,TRAFFIC C,FC-12.5,PG 76-22	101.64	TN	\$122.75	\$12,476.31

#### Pavement Marking Subcomponent

Description	Value
Include Thermo/Tape/Other	Y
Pavement Type	Asphalt
Solid Stripe No. of Paint Applications	1
Solid Stripe No. of Stripes	2
Skip Stripe No. of Paint Applications	1
Skip Stripe No. of Stripes	0

#### Pay Items

Pay item	Description	Quantity	Unit	Unit Price	Extended Amount
----------	-------------	----------	------	------------	-----------------

710-11-101	PAINTED PAVT MARK,STD,WHITE,SOLID,6"	0.28 GM	\$1,080.33	\$302.49
711-15-201	THERMOPLASTIC, STD- OP,YELLOW, SOLID, 6"	0.28 GM	\$4,988.35	\$1,396.74
711-16-101	THERMOPLASTIC, STD-OTH, WHITE, SOLID, 6"	0.28 GM	\$3,986.79	\$1,116.30
<b>Roadway Component Total</b>				<b>\$177,277.15</b>

### SHOULDER COMPONENT

#### User Input Data

Description	Value
Total Outside Shoulder Width L/R	10.00 / 12.00
Total Outside Shoulder Perf. Turf Width L/R	4.00 / 2.00
Paved Outside Shoulder Width L/R	6.00 / 10.00
Structural Spread Rate	220
Friction Course Spread Rate	165
Total Width (T) / 8" Overlap (O)	T
Rumble Strips i <sub>l</sub> ½No. of Sides	2

#### Pay Items

Pay item	Description	Quantity	Unit	Unit Price	Extended Amount
285-704	OPTIONAL BASE,BASE GROUP 04	1,368.34	SY	\$35.24	\$48,220.30
334-1-53	SUPERPAVE ASPH CONC, TRAF C, PG76-22	144.55	TN	\$127.05	\$18,365.08
337-7-83	ASPH CONC FC,TRAFFIC C,FC- 12.5,PG 76-22	108.42	TN	\$122.75	\$13,308.56
546-72-1	GROUND-IN RUMBLE STRIPS, 16"	0.28	GM	\$881.71	\$246.88
570-1-1	PERFORMANCE TURF	492.80	SY	\$3.19	\$1,572.03

#### Erosion Control

#### Pay Items

Pay item	Description	Quantity	Unit	Unit Price	Extended Amount
104-10-3	SEDIMENT BARRIER	1,921.92	LF	\$1.20	\$2,306.30
104-11	FLOATING TURBIDITY BARRIER	35.00	LF	\$9.49	\$332.15
104-12	STAKED TURBIDITY BARRIER- NYL REINF PVC	35.00	LF	\$4.44	\$155.40
104-15	SOIL TRACKING PREVENTION DEVICE	1.00	EA	\$2,988.11	\$2,988.11
107-1	LITTER REMOVAL	1.70	AC	\$20.76	\$35.29
107-2	MOWING	1.70	AC	\$46.89	\$79.71

**Shoulder Component Total** **\$87,609.81**

### DRAINAGE COMPONENT

#### Pay Items

Pay item	Description	Quantity	Unit	Unit Price	Extended Amount
430-174-124	PIPE CULV, OPT MATL, ROUND,24"SD	112.00	LF	\$126.21	\$14,135.52
430-175-136	PIPE CULV, OPT MATL, ROUND, 36"S/CD	24.00	LF	\$342.26	\$8,214.24
430-984-129	MITERED END SECT, OPTIONAL RD, 24" SD	6.00	EA	\$2,253.96	\$13,523.76
570-1-1	PERFORMANCE TURF	98.56	SY	\$3.19	\$314.41

**Drainage Component Total**

**\$36,187.93**

**SIGNING COMPONENT**

**Pay Items**

<b>Pay item</b>	<b>Description</b>	<b>Quantity</b>	<b>Unit</b>	<b>Unit Price</b>	<b>Extended Amount</b>
700-1-11	SINGLE POST SIGN, F&I GM, <12 SF	1.00	AS	\$380.22	\$380.22
700-1-12	SINGLE POST SIGN, F&I GM, 12-20 SF	3.00	AS	\$1,503.18	\$4,509.54
700-2-14	MULTI- POST SIGN, F&I GM, 31-50 SF	1.00	AS	\$5,637.01	\$5,637.01
<b>Signing Component Total</b>					<b>\$10,526.77</b>

**INTELLIGENT TRAFFIC SYSTEM (ITS) COMPONENT**

**Description of Work**

General ITS per LF of roadway.

**EX-Items**

<b>Pay item</b>	<b>Description</b>	<b>Quantity</b>	<b>Unit</b>	<b>Unit Price</b>	<b>Extended Amount</b>
000-000	GENERAL ITS <b>Comment:</b> General ITS per LF of roadway.	1,120.00	LF	\$70.00	\$78,400.00
<b>Intelligent Traffic System (ITS) Component Total</b>					<b>\$78,400.00</b>

**LIGHTING COMPONENT**

**Rural Lighting Subcomponent**

**Description**

Multiplier (Number of Poles)

**Value**

6

**Pay Items**

<b>Pay item</b>	<b>Description</b>	<b>Quantity</b>	<b>Unit</b>	<b>Unit Price</b>	<b>Extended Amount</b>
630-2-11	CONDUIT, F& I, OPEN TRENCH	1,200.00	LF	\$9.76	\$11,712.00
635-2-11	PULL & SPLICE BOX, F&I, 13" x 24"	6.00	EA	\$767.98	\$4,607.88
715-1-13	LIGHTING CONDUCTORS, F&I, INSUL, NO.4-2	3,600.00	LF	\$2.62	\$9,432.00
715-4-14	LIGHT POLE COMPLETE, F&I-STD, 45'	6.00	EA	\$7,063.23	\$42,379.38
715-500-1	POLE CABLE DIST SYS, CONVENTIONAL	6.00	EA	\$621.64	\$3,729.84
<b>Subcomponent Total</b>					<b>\$71,861.10</b>
<b>Lighting Component Total</b>					<b>\$71,861.10</b>

**LANDSCAPING COMPONENT**

**User Input Data**

**Description**

Cost %

**Value**

2.00

Component Detail

N

**Landscaping Component Total**

**\$6,021.50**



Sequence: 33 NUR - New Construction, Undivided, Rural

Net Length: 0.119 MI  
629 LF

Description: Sinclair Ramp D-1 (1-Lane). Connector Road/Sinclair Rd to NB SR 429

**EARTHWORK COMPONENT**

**User Input Data**

Description	Value
Standard Clearing and Grubbing Limits L/R	100.00 / 100.00
Incidental Clearing and Grubbing Area	0.00
Alignment Number	1
Distance	0.119
Top of Structural Course For Begin Section	105.00
Top of Structural Course For End Section	105.00
Horizontal Elevation For Begin Section	100.00
Horizontal Elevation For End Section	100.00
Front Slope L/R	6 to 1 / 6 to 1
Outside Shoulder Cross Slope L/R	5.00 % / 6.00 %
Roadway Cross Slope L/R	2.00 % / 2.00 %

**Pay Items**

Pay item	Description	Quantity	Unit	Unit Price	Extended Amount
110-1-1	CLEARING & GRUBBING	2.88	AC	\$21,000.00	\$60,480.00
120-6	EMBANKMENT	3,161.15	CY	\$20.88	\$66,004.81
<b>Earthwork Component Total</b>					<b>\$126,484.81</b>

**ROADWAY COMPONENT**

**User Input Data**

Description	Value
Number of Lanes	1
Roadway Pavement Width L/R	0.00 / 15.00
Structural Spread Rate	440
Friction Course Spread Rate	165

**Pay Items**

Pay item	Description	Quantity	Unit	Unit Price	Extended Amount
160-4	TYPE B STABILIZATION	1,886.54	SY	\$11.66	\$21,997.06
285-712	OPTIONAL BASE,BASE GROUP 12	1,071.14	SY	\$73.16	\$78,364.60
334-1-53	SUPERPAVE ASPH CONC, TRAF C, PG76-22	230.58	TN	\$127.05	\$29,295.19
337-7-83	ASPH CONC FC,TRAFFIC C,FC-12.5,PG 76-22	86.47	TN	\$122.75	\$10,614.19

**Pavement Marking Subcomponent**

Description	Value
Include Thermo/Tape/Other	Y
Pavement Type	Asphalt
Solid Stripe No. of Paint Applications	1
Solid Stripe No. of Stripes	2
Skip Stripe No. of Paint Applications	1
Skip Stripe No. of Stripes	0

**Pay Items**

Pay item	Description	Quantity	Unit	Unit Price	Extended Amount
----------	-------------	----------	------	------------	-----------------



710-11-101	PAINTED PAVT MARK,STD,WHITE,SOLID,6"	0.24 GM	\$1,080.33	\$259.28
711-15-201	THERMOPLASTIC, STD- OP,YELLOW, SOLID, 6"	0.24 GM	\$4,988.35	\$1,197.20
711-16-101	THERMOPLASTIC, STD-OTH, WHITE, SOLID, 6"	0.24 GM	\$3,986.79	\$956.83

#### Peripherals Subcomponent

Description	Value
Off Road Bike Path(s)	0
Off Road Bike Path Width L/R	0.00 / 0.00
Bike Path Structural Spread Rate	0
Noise Barrier Wall Length	0.00
Noise Barrier Wall Begin Height	0.00
Noise Barrier Wall End Height	0.00

#### Roadway Component Total

\$142,684.35

### SHOULDER COMPONENT

#### User Input Data

Description	Value
Total Outside Shoulder Width L/R	6.00 / 6.00
Total Outside Shoulder Perf. Turf Width L/R	4.00 / 2.00
Paved Outside Shoulder Width L/R	2.00 / 4.00
Structural Spread Rate	220
Friction Course Spread Rate	165
Total Width (T) / 8" Overlap (O)	T
Rumble Strips $i_c \frac{1}{2}$ No. of Sides	2

#### Pay Items

Pay item	Description	Quantity	Unit	Unit Price	Extended Amount
285-705	OPTIONAL BASE,BASE GROUP 05	465.35	SY	\$40.53	\$18,860.64
334-1-53	SUPERPAVE ASPH CONC, TRAF C, PG76-22	46.12	TN	\$127.05	\$5,859.55
337-7-83	ASPH CONC FC,TRAFFIC C,FC- 12.5,PG 76-22	34.59	TN	\$122.75	\$4,245.92
546-72-1	GROUND-IN RUMBLE STRIPS, 16"	0.24	GM	\$881.71	\$211.61
570-1-1	PERFORMANCE TURF	419.23	SY	\$3.19	\$1,337.34

#### Erosion Control

#### Pay Items

Pay item	Description	Quantity	Unit	Unit Price	Extended Amount
104-10-3	SEDIMENT BARRIER	1,635.00	LF	\$1.20	\$1,962.00
104-11	FLOATING TURBIDITY BARRIER	29.78	LF	\$9.49	\$282.61
104-12	STAKED TURBIDITY BARRIER- NYL REINF PVC	29.78	LF	\$4.44	\$132.22
104-15	SOIL TRACKING PREVENTION DEVICE	1.00	EA	\$2,988.11	\$2,988.11
107-1	LITTER REMOVAL	1.44	AC	\$20.76	\$29.89
107-2	MOWING	1.44	AC	\$46.89	\$67.52

#### Shoulder Component Total

\$35,977.41

### DRAINAGE COMPONENT

#### Pay Items

Pay item	Description	Quantity	Unit	Unit Price	Extended Amount
430-174-124	PIPE CULV, OPT MATL, ROUND,24"SD	96.00	LF	\$126.21	\$12,116.16
430-175-136	PIPE CULV, OPT MATL, ROUND, 36"S/CD	24.00	LF	\$342.26	\$8,214.24
430-984-129	MITERED END SECT, OPTIONAL RD, 24" SD	5.00	EA	\$2,253.96	\$11,269.80
570-1-1	PERFORMANCE TURF	83.85	SY	\$3.19	\$267.48
<b>Drainage Component Total</b>					<b>\$31,867.68</b>

### SIGNING COMPONENT

Pay Items					
Pay item	Description	Quantity	Unit	Unit Price	Extended Amount
700-1-11	SINGLE POST SIGN, F&I GM, <12 SF	1.00	AS	\$380.22	\$380.22
700-1-12	SINGLE POST SIGN, F&I GM, 12-20 SF	3.00	AS	\$1,503.18	\$4,509.54
700-2-14	MULTI- POST SIGN, F&I GM, 31-50 SF	1.00	AS	\$5,637.01	\$5,637.01
<b>Signing Component Total</b>					<b>\$10,526.77</b>

### INTELLIGENT TRAFFIC SYSTEM (ITS) COMPONENT

#### Description of Work

General ITS per LF of roadway.

#### EX-Items

Pay item	Description	Quantity	Unit	Unit Price	Extended Amount
000-000	GENERAL ITS	629.00	LF	\$70.00	\$44,030.00
<b>Comment:</b> General ITS per LF of roadway.					
<b>Intelligent Traffic System (ITS) Component Total</b>					<b>\$44,030.00</b>

### LIGHTING COMPONENT

#### Rural Lighting Subcomponent

Description					Value
Multiplier (Number of Poles)					2
Pay Items					
Pay item	Description	Quantity	Unit	Unit Price	Extended Amount
630-2-11	CONDUIT, F& I, OPEN TRENCH	400.00	LF	\$9.76	\$3,904.00
635-2-11	PULL & SPLICE BOX, F&I, 13" x 24"	2.00	EA	\$767.98	\$1,535.96
715-1-13	LIGHTING CONDUCTORS, F&I, INSUL, NO.4-2	1,200.00	LF	\$2.62	\$3,144.00
715-4-14	LIGHT POLE COMPLETE, F&I-STD, 45'	2.00	EA	\$7,063.23	\$14,126.46
715-500-1	POLE CABLE DIST SYS, CONVENTIONAL	2.00	EA	\$621.64	\$1,243.28
<b>Subcomponent Total</b>					<b>\$23,953.70</b>
<b>Lighting Component Total</b>					<b>\$23,953.70</b>

**LANDSCAPING COMPONENT**

**User Input Data**

<b>Description</b>	<b>Value</b>
Cost %	2.00
Component Detail	N

---

<b>Landscaping Component Total</b>	<b>\$4,210.59</b>
------------------------------------	-------------------

---

<b>Sequence 33 Total</b>	<b>\$419,735.31</b>
--------------------------	---------------------

---

Sequence: 35 NDR - New Construction, Divided, Rural

Net Length: 0.945 MI  
4,987 LF

Description: I-4 Mainline: 4-Lanes EB GUL, 2-Lanes-EB EL, 5-Lanes WB GUL, 2-Lanes WB EL. DMS.

### EARTHWORK COMPONENT

#### User Input Data

Description	Value
Standard Clearing and Grubbing Limits L/R	230.00 / 214.00
Incidental Clearing and Grubbing Area	0.00
Alignment Number	1
Distance	0.945
Top of Structural Course For Begin Section	105.00
Top of Structural Course For End Section	105.00
Horizontal Elevation For Begin Section	100.00
Horizontal Elevation For End Section	100.00
Front Slope L/R	6 to 1 / 6 to 1
Median Slope L/R	6 to 1 / 6 to 1
Median Shoulder Cross Slope L/R	5.00 % / 5.00 %
Outside Shoulder Cross Slope L/R	6.00 % / 6.00 %
Roadway Cross Slope L/R	2.00 % / 2.00 %

#### Pay Items

Pay item	Description	Quantity	Unit	Unit Price	Extended Amount
110-1-1	CLEARING & GRUBBING	50.80	AC	\$21,000.00	\$1,066,800.00
120-6	EMBANKMENT	156,677.14	CY	\$20.88	\$3,271,418.68
<b>Earthwork Component Total</b>					<b>\$4,338,218.68</b>

### ROADWAY COMPONENT

#### User Input Data

Description	Value
Number of Lanes	6
Roadway Pavement Width L/R	90.00 / 76.00
Structural Spread Rate	440
Friction Course Spread Rate	80

#### Pay Items

Pay item	Description	Quantity	Unit	Unit Price	Extended Amount
160-4	TYPE B STABILIZATION	116,362.40	SY	\$11.66	\$1,356,785.58
285-712	OPTIONAL BASE,BASE GROUP 12	92,713.13	SY	\$73.16	\$6,782,892.59
334-1-53	SUPERPAVE ASPH CONC, TRAF C, PG76-22	20,235.98	TN	\$127.05	\$2,570,981.26
337-7-25	ASPH CONC FC,INC BIT,FC-5,PG76-22	3,679.27	TN	\$159.94	\$588,462.44

#### X-Items

Pay item	Description	Quantity	Unit	Unit Price	Extended Amount
546-72-1	GROUND-IN RUMBLE STRIPS, 16"	3.89	GM	\$881.71	\$3,429.85
<b>Comment:</b> Express Lane Rumble Strips					

#### Pavement Marking Subcomponent

Description	Value
Include Thermo/Tape/Other	Y
Pavement Type	Asphalt
Solid Stripe No. of Paint Applications	1

Solid Stripe No. of Stripes	4
Skip Stripe No. of Paint Applications	1
Skip Stripe No. of Stripes	4

**Pay Items**

Pay item	Description	Quantity Unit	Unit Price	Extended Amount
706-1-1	RAISED PAVMT MARK, TYPE B W/O FINAL SURF	638.00 EA	\$3.58	\$2,284.04
710-11-101	PAINTED PAVT MARK,STD,WHITE,SOLID,6"	3.78 GM	\$1,080.33	\$4,083.65
710-11-131	PAINTED PAVT MARK,STD,WHITE,SKIP, 6"	3.78 GM	\$460.80	\$1,741.82
711-15-101	THERMOPLASTIC, STD-OP, WHITE, SOLID, 6"	3.78 GM	\$4,966.76	\$18,774.35
711-15-131	THERMOPLASTIC, STD-OP, WHITE, SKIP, 6"	3.78 GM	\$1,845.33	\$6,975.35
711-15-201	THERMOPLASTIC, STD-OP,YELLOW, SOLID, 6"	3.78 GM	\$4,988.35	\$18,855.96

**Peripherals Subcomponent**

Description	Value
Off Road Bike Path(s)	0
Off Road Bike Path Width L/R	0.00 / 0.00
Bike Path Structural Spread Rate	0
Noise Barrier Wall Length	0.00
Noise Barrier Wall Begin Height	0.00
Noise Barrier Wall End Height	0.00

**Pay Items**

Pay item	Description	Quantity Unit	Unit Price	Extended Amount
521-72-40	SHLDR CONC BARRIER,38" OR 44" HEIGHT	22,227.00 LF	\$306.25	\$6,807,018.75
550-10-120	FENCING, TYPE A, 5.1-6.0, STANDARD	9,976.00 LF	\$9.26	\$92,377.76
<b>Roadway Component Total</b>				<b>\$18,254,663.40</b>

**SHOULDER COMPONENT**

**User Input Data**

Description	Value
Total Outside Shoulder Width L/R	12.00 / 12.00
Total Outside Shoulder Perf. Turf Width L/R	0.00 / 0.00
Paved Outside Shoulder Width L/R	12.00 / 12.00
Structural Spread Rate	220
Friction Course Spread Rate	80
Total Width (T) / 8" Overlap (O)	0
Rumble Strips $\frac{1}{2}$ No. of Sides	2

**Pay Items**

Pay item	Description	Quantity Unit	Unit Price	Extended Amount
285-705	OPTIONAL BASE,BASE GROUP 05	13,664.27 SY	\$40.53	\$553,812.86
334-1-13	SUPERPAVE ASPHALTIC CONC, TRAFFIC C	1,462.84 TN	\$126.72	\$185,371.08
337-7-25	ASPH CONC FC,INC BIT,FC-5,PG76-22	29.26 TN	\$159.94	\$4,679.84
546-72-1	GROUND-IN RUMBLE STRIPS, 16"	1.89 GM	\$881.71	\$1,666.43

**Erosion Control****Pay Items**

Pay item	Description	Quantity Unit	Unit Price	Extended Amount
104-10-3	SEDIMENT BARRIER	12,966.10 LF	\$1.20	\$15,559.32
104-11	FLOATING TURBIDITY BARRIER	236.12 LF	\$9.49	\$2,240.78
104-12	STAKED TURBIDITY BARRIER- NYL REINF PVC	236.12 LF	\$4.44	\$1,048.37
104-15	SOIL TRACKING PREVENTION DEVICE	1.00 EA	\$2,988.11	\$2,988.11
104-18	INLET PROTECTION SYSTEM	6.00 EA	\$88.37	\$530.22
107-1	LITTER REMOVAL	22.89 AC	\$20.76	\$475.20
107-2	MOWING	22.89 AC	\$46.89	\$1,073.31
<b>Shoulder Component Total</b>				<b>\$769,445.52</b>

**MEDIAN COMPONENT****User Input Data**

Description	Value
Total Median Width	70.00
Performance Turf Width	61.50
Total Median Shoulder Width L/R	10.00 / 10.00
Paved Median Shoulder Width L/R	10.00 / 10.00
Structural Spread Rate	220
Friction Course Spread Rate	80
Total Width (T) / 8" Overlap (O)	0
Rumble Strips i <sub>l</sub> ½No. of Sides	2

**Pay Items**

Pay item	Description	Quantity Unit	Unit Price	Extended Amount
285-705	OPTIONAL BASE,BASE GROUP 05	11,447.84 SY	\$40.53	\$463,980.96
334-1-53	SUPERPAVE ASPH CONC, TRAF C, PG76-22	1,219.03 TN	\$127.05	\$154,877.76
337-7-25	ASPH CONC FC,INC BIT,FC- 5,PG76-22	29.26 TN	\$159.94	\$4,679.84
546-72-1	GROUND-IN RUMBLE STRIPS, 16"	2.00 GM	\$881.71	\$1,763.42
570-1-2	PERFORMANCE TURF, SOD	34,077.56 SY	\$4.09	\$139,377.22
<b>Median Component Total</b>				<b>\$764,679.20</b>

**DRAINAGE COMPONENT****Pay Items**

Pay item	Description	Quantity Unit	Unit Price	Extended Amount
425-1-551	INLETS, DT BOT, TYPE E, <10'	6.00 EA	\$13,191.95	\$79,151.70
430-174-124	PIPE CULV, OPT MATL, ROUND,24"SD	760.00 LF	\$126.21	\$95,919.60
430-175-124	PIPE CULV, OPT MATL, ROUND, 24"S/CD	328.00 LF	\$128.82	\$42,252.96
430-175-136	PIPE CULV, OPT MATL, ROUND, 36"S/CD	280.00 LF	\$342.26	\$95,832.80
430-984-129	MITERED END SECT, OPTIONAL RD, 24" SD	38.00 EA	\$2,253.96	\$85,650.48
524-1-1	CONCRETE DITCH PAVT, NR, 3"	1,889.00 SY	\$218.44	\$412,633.16
570-1-1	PERFORMANCE TURF	664.93 SY	\$3.19	\$2,121.13

**X-Items**

Pay item	Description	Quantity Unit	Unit Price	Extended Amount
425-1-921	INLETS, ADJACENT BARRIER, <=10'	111.00 EA	\$5,906.88	\$655,663.68
<b>Drainage Component Total</b>				<b>\$1,469,225.51</b>

### SIGNING COMPONENT

#### Pay Items

Pay item	Description	Quantity Unit	Unit Price	Extended Amount
700-1-11	SINGLE POST SIGN, F&I GM, <12 SF	2.00 AS	\$380.22	\$760.44
700-1-12	SINGLE POST SIGN, F&I GM, 12-20 SF	23.00 AS	\$1,503.18	\$34,573.14
700-2-14	MULTI- POST SIGN, F&I GM, 31-50 SF	2.00 AS	\$5,637.01	\$11,274.02
700-2-15	MULTI- POST SIGN, F&I GM, 51-100 SF	6.00 AS	\$7,713.11	\$46,278.66

#### X-Items

Pay item	Description	Quantity Unit	Unit Price	Extended Amount
700-4-114	OH STATIC SIGN STR, F&I, C 41-50 FT	3.00 EA	\$94,981.18	\$284,943.54
700-4-127	OH STATIC SIGN STR, F&I, S 151-200 FT	2.00 EA	\$211,285.18	\$422,570.36
700-9-137	WALK-IN DYN MESS SIGN,F&I, FULL,201-	1.00 EA	\$132,815.00	\$132,815.00

**Signing Component Total** \$933,215.16

### INTELLIGENT TRAFFIC SYSTEM (ITS) COMPONENT

#### Description of Work

#### EX-Items

Pay item	Description	Quantity Unit	Unit Price	Extended Amount
000-000	GENERAL ITS Comment: General ITS.	4,988.00 LF	\$70.00	\$349,160.00

**Intelligent Traffic System (ITS) Component Total** \$349,160.00

### LIGHTING COMPONENT

#### Rural Lighting Subcomponent

Description	Value
Multiplier (Number of Poles)	106

#### Pay Items

Pay item	Description	Quantity Unit	Unit Price	Extended Amount
630-2-11	CONDUIT, F& I, OPEN TRENCH	21,200.00 LF	\$9.76	\$206,912.00
635-2-11	PULL & SPLICE BOX, F&I, 13" x 24"	106.00 EA	\$767.98	\$81,405.88
715-1-13	LIGHTING CONDUCTORS, F&I, INSUL, NO.4-2	63,600.00 LF	\$2.62	\$166,632.00
715-4-14	LIGHT POLE COMPLETE, F&I-STD, 45'	106.00 EA	\$7,063.23	\$748,702.38
715-500-1	POLE CABLE DIST SYS, CONVENTIONAL	106.00 EA	\$621.64	\$65,893.84

**Subcomponent Total** \$1,269,546.10

**Lighting Component Total** \$1,269,546.10

---

**LANDSCAPING COMPONENT**

**User Input Data**

<b>Description</b>	<b>Value</b>
Cost %	2.00
Component Detail	N

**Landscaping Component Total** \$425,160.27

---

**Sequence 35 Total** \$28,573,313.84

---



Sequence: 36 NDR - New Construction, Divided, Rural

Net Length: 0.136 MI  
719 LF

Description: I-4 Mainline: 4-Lanes EB GUL, 2-Lanes-EB EL, 6-Lanes WB GUL, 2-Lanes WB EL.

### EARTHWORK COMPONENT

#### User Input Data

Description	Value
Standard Clearing and Grubbing Limits L/R	242.00 / 214.00
Incidental Clearing and Grubbing Area	0.00
Alignment Number	1
Distance	0.136
Top of Structural Course For Begin Section	105.00
Top of Structural Course For End Section	105.00
Horizontal Elevation For Begin Section	100.00
Horizontal Elevation For End Section	100.00
Front Slope L/R	6 to 1 / 6 to 1
Median Slope L/R	6 to 1 / 6 to 1
Median Shoulder Cross Slope L/R	5.00 % / 5.00 %
Outside Shoulder Cross Slope L/R	6.00 % / 6.00 %
Roadway Cross Slope L/R	2.00 % / 2.00 %

#### Pay Items

Pay item	Description	Quantity	Unit	Unit Price	Extended Amount
110-1-1	CLEARING & GRUBBING	7.52	AC	\$21,000.00	\$157,920.00
120-6	EMBANKMENT	22,734.41	CY	\$20.88	\$474,694.48
<b>Earthwork Component Total</b>					<b>\$632,614.48</b>

### ROADWAY COMPONENT

#### User Input Data

Description	Value
Number of Lanes	6
Roadway Pavement Width L/R	90.00 / 76.00
Structural Spread Rate	440
Friction Course Spread Rate	80

#### Pay Items

Pay item	Description	Quantity	Unit	Unit Price	Extended Amount
160-4	TYPE B STABILIZATION	16,779.84	SY	\$11.66	\$195,652.93
285-712	OPTIONAL BASE,BASE GROUP 12	13,369.54	SY	\$73.16	\$978,115.55
334-1-53	SUPERPAVE ASPH CONC, TRAF C, PG76-22	2,918.09	TN	\$127.05	\$370,743.33
337-7-25	ASPH CONC FC,INC BIT,FC-5,PG76-22	530.56	TN	\$159.94	\$84,857.77

#### X-Items

Pay item	Description	Quantity	Unit	Unit Price	Extended Amount
546-72-1	GROUND-IN RUMBLE STRIPS, 16"	0.82	GM	\$881.71	\$723.00
<b>Comment:</b> Express Lane and Median Rumble Strips					

#### Pavement Marking Subcomponent

Description	Value
Include Thermo/Tape/Other	Y
Pavement Type	Asphalt
Solid Stripe No. of Paint Applications	1

Solid Stripe No. of Stripes	4
Skip Stripe No. of Paint Applications	1
Skip Stripe No. of Stripes	4

**Pay Items**

Pay item	Description	Quantity	Unit	Unit Price	Extended Amount
706-1-1	RAISED PAVMT MARK, TYPE B W/O FINAL SURF	92.00	EA	\$3.58	\$329.36
710-11-101	PAINTED PAVT MARK,STD,WHITE,SOLID,6"	0.54	GM	\$1,080.33	\$583.38
710-11-131	PAINTED PAVT MARK,STD,WHITE,SKIP, 6"	0.54	GM	\$460.80	\$248.83
711-15-101	THERMOPLASTIC, STD-OP, WHITE, SOLID, 6"	0.54	GM	\$4,966.76	\$2,682.05
711-15-131	THERMOPLASTIC, STD-OP, WHITE, SKIP, 6"	0.54	GM	\$1,845.33	\$996.48

**Peripherals Subcomponent**

Description	Value
Off Road Bike Path(s)	0
Off Road Bike Path Width L/R	0.00 / 0.00
Bike Path Structural Spread Rate	0
Noise Barrier Wall Length	0.00
Noise Barrier Wall Begin Height	0.00
Noise Barrier Wall End Height	0.00

**Pay Items**

Pay item	Description	Quantity	Unit	Unit Price	Extended Amount
521-72-40	SHLDR CONC BARRIER,38" OR 44" HEIGHT	2,957.00	LF	\$306.25	\$905,581.25
550-10-120	FENCING, TYPE A, 5.1-6.0, STANDARD	1,438.00	LF	\$9.26	\$13,315.88
<b>Roadway Component Total</b>					<b>\$2,553,829.81</b>

**SHOULDER COMPONENT**

**User Input Data**

Description	Value
Total Outside Shoulder Width L/R	12.00 / 12.00
Total Outside Shoulder Perf. Turf Width L/R	0.00 / 0.00
Paved Outside Shoulder Width L/R	12.00 / 12.00
Structural Spread Rate	220
Friction Course Spread Rate	80
Total Width (T) / 8" Overlap (O)	0
Rumble Strips $\frac{1}{2}$ No. of Sides	2

**Pay Items**

Pay item	Description	Quantity	Unit	Unit Price	Extended Amount
285-705	OPTIONAL BASE,BASE GROUP 05	1,970.43	SY	\$40.53	\$79,861.53
334-1-13	SUPERPAVE ASPHALTIC CONC, TRAFFIC C	210.95	TN	\$126.72	\$26,731.58
337-7-25	ASPH CONC FC,INC BIT,FC- 5,PG76-22	4.22	TN	\$159.94	\$674.95
546-72-1	GROUND-IN RUMBLE STRIPS, 16"	0.27	GM	\$881.71	\$238.06

**Erosion Control**

**Pay Items**

Pay item	Description	Quantity	Unit	Unit Price	Extended Amount
104-10-3	SEDIMENT BARRIER	1,869.75	LF	\$1.20	\$2,243.70
104-11	FLOATING TURBIDITY BARRIER	34.05	LF	\$9.49	\$323.13
104-12	STAKED TURBIDITY BARRIER- NYL REINF PVC	34.05	LF	\$4.44	\$151.18
104-15	SOIL TRACKING PREVENTION DEVICE	1.00	EA	\$2,988.11	\$2,988.11
104-18	INLET PROTECTION SYSTEM	1.00	EA	\$88.37	\$88.37
107-1	LITTER REMOVAL	3.30	AC	\$20.76	\$68.51
107-2	MOWING	3.30	AC	\$46.89	\$154.74
<b>Shoulder Component Total</b>					<b>\$113,523.86</b>

**MEDIAN COMPONENT****User Input Data**

Description	Value
Total Median Width	72.00
Performance Turf Width	61.50
Total Median Shoulder Width L/R	10.00 / 10.00
Paved Median Shoulder Width L/R	10.00 / 10.00
Structural Spread Rate	220
Friction Course Spread Rate	80
Total Width (T) / 8" Overlap (O)	O
Rumble Strips i; 1/2No. of Sides	2

**Pay Items**

Pay item	Description	Quantity	Unit	Unit Price	Extended Amount
285-705	OPTIONAL BASE,BASE GROUP 05	1,650.82	SY	\$40.53	\$66,907.73
334-1-53	SUPERPAVE ASPH CONC, TRAF C, PG76-22	175.79	TN	\$127.05	\$22,334.12
337-7-25	ASPH CONC FC,INC BIT,FC- 5,PG76-22	4.22	TN	\$159.94	\$674.95
570-1-2	PERFORMANCE TURF, SOD	4,914.10	SY	\$4.09	\$20,098.67
<b>Median Component Total</b>					<b>\$110,015.47</b>

**DRAINAGE COMPONENT****Pay Items**

Pay item	Description	Quantity	Unit	Unit Price	Extended Amount
425-1-551	INLETS, DT BOT, TYPE E, <10'	1.00	EA	\$13,191.95	\$13,191.95
430-174-124	PIPE CULV, OPT MATL, ROUND,24"SD	112.00	LF	\$126.21	\$14,135.52
430-175-124	PIPE CULV, OPT MATL, ROUND, 24"S/CD	48.00	LF	\$128.82	\$6,183.36
430-175-136	PIPE CULV, OPT MATL, ROUND, 36"S/CD	48.00	LF	\$342.26	\$16,428.48
430-984-129	MITERED END SECT, OPTIONAL RD, 24" SD	6.00	EA	\$2,253.96	\$13,523.76
524-1-1	CONCRETE DITCH PAVT, NR, 3"	272.40	SY	\$218.44	\$59,503.06
570-1-1	PERFORMANCE TURF	95.88	SY	\$3.19	\$305.86

**X-Items**

Pay item	Description	Quantity	Unit	Unit Price	Extended Amount
----------	-------------	----------	------	------------	-----------------

425-1-921	INLETS, ADJACENT BARRIER, <=10'	11.00 EA	\$5,906.88	\$64,975.68
-----------	------------------------------------	----------	------------	-------------

<b>Drainage Component Total</b>				\$188,247.67
---------------------------------	--	--	--	--------------

**SIGNING COMPONENT**

**Pay Items**

Pay item	Description	Quantity	Unit	Unit Price	Extended Amount
700-1-11	SINGLE POST SIGN, F&I GM, <12 SF	1.00	AS	\$380.22	\$380.22
700-1-12	SINGLE POST SIGN, F&I GM, 12-20 SF	4.00	AS	\$1,503.18	\$6,012.72
700-2-14	MULTI- POST SIGN, F&I GM, 31-50 SF	1.00	AS	\$5,637.01	\$5,637.01
700-2-15	MULTI- POST SIGN, F&I GM, 51-100 SF	1.00	AS	\$7,713.11	\$7,713.11

<b>Signing Component Total</b>				\$19,743.06
--------------------------------	--	--	--	-------------

**INTELLIGENT TRAFFIC SYSTEM (ITS) COMPONENT**

**Description of Work**

**EX-Items**

Pay item	Description	Quantity	Unit	Unit Price	Extended Amount
000-000	GENERAL ITS	719.00	LF	\$70.00	\$50,330.00
	<b>Comment:</b> General ITS.				

<b>Intelligent Traffic System (ITS) Component Total</b>				\$50,330.00
---	--	--	--	-------------

**LIGHTING COMPONENT**

**Rural Lighting Subcomponent**

<b>Description</b>	<b>Value</b>
Multiplier (Number of Poles)	15

**Pay Items**

Pay item	Description	Quantity	Unit	Unit Price	Extended Amount
630-2-11	CONDUIT, F& I, OPEN TRENCH	3,000.00	LF	\$9.76	\$29,280.00
635-2-11	PULL & SPLICE BOX, F&I, 13" x 24"	15.00	EA	\$767.98	\$11,519.70
715-1-13	LIGHTING CONDUCTORS, F&I, INSUL, NO.4-2	9,000.00	LF	\$2.62	\$23,580.00
715-4-14	LIGHT POLE COMPLETE, F&I-STD, 45'	15.00	EA	\$7,063.23	\$105,948.45
715-500-1	POLE CABLE DIST SYS, CONVENTIONAL	15.00	EA	\$621.64	\$9,324.60
<b>Subcomponent Total</b>					\$179,652.75

<b>Lighting Component Total</b>				\$179,652.75
---------------------------------	--	--	--	--------------

**LANDSCAPING COMPONENT**

**User Input Data**

Description	Value
Cost %	2.00
Component Detail	N

**Landscaping Component Total**

**\$59,312.34**

---

**Sequence 36 Total**

**\$3,907,269.44**

---

Sequence: 37 NDR - New Construction, Divided, Rural

Net Length: 0.269 MI  
1,420 LF

Description: I-4 Mainline: 4-Lanes EB GUL, 3-Lanes EB EL, 6-Lanes WB GUL, 3-Lanes WB EL.

**EARTHWORK COMPONENT**

**User Input Data**

Description	Value
Standard Clearing and Grubbing Limits L/R	260.00 / 226.00
Incidental Clearing and Grubbing Area	0.00
Alignment Number	1
Distance	0.269
Top of Structural Course For Begin Section	110.00
Top of Structural Course For End Section	110.00
Horizontal Elevation For Begin Section	100.00
Horizontal Elevation For End Section	100.00
Front Slope L/R	6 to 1 / 6 to 1
Median Slope L/R	6 to 1 / 6 to 1
Median Shoulder Cross Slope L/R	5.00 % / 5.00 %
Outside Shoulder Cross Slope L/R	6.00 % / 6.00 %
Roadway Cross Slope L/R	2.00 % / 2.00 %

**Pay Items**

Pay item	Description	Quantity Unit	Unit Price	Extended Amount
110-1-1	CLEARING & GRUBBING	15.85 AC	\$21,000.00	\$332,850.00
120-6	EMBANKMENT	138,530.12 CY	\$20.88	\$2,892,508.91
<b>Earthwork Component Total</b>				<b>\$3,225,358.91</b>

**ROADWAY COMPONENT**

**User Input Data**

Description	Value
Number of Lanes	6
Roadway Pavement Width L/R	96.00 / 84.00
Structural Spread Rate	440
Friction Course Spread Rate	80

**Pay Items**

Pay item	Description	Quantity Unit	Unit Price	Extended Amount
160-4	TYPE B STABILIZATION	41,647.23 SY	\$11.66	\$485,606.70
285-712	OPTIONAL BASE,BASE GROUP 12	28,604.08 SY	\$73.16	\$2,092,674.49
334-1-53	SUPERPAVE ASPH CONC, TRAF C, PG76-22	6,247.08 TN	\$127.05	\$793,691.51
337-7-25	ASPH CONC FC,INC BIT,FC-5,PG76-22	1,135.83 TN	\$159.94	\$181,664.65

**X-Items**

Pay item	Description	Quantity Unit	Unit Price	Extended Amount
546-72-1	GROUND-IN RUMBLE STRIPS, 16"	1.54 GM	\$881.71	\$1,357.83
	<b>Comment:</b> Express Lane Rumble Strips			

**Pavement Marking Subcomponent**

Description	Value
Include Thermo/Tape/Other	Y
Pavement Type	Asphalt
Solid Stripe No. of Paint Applications	1

Solid Stripe No. of Stripes	4
Skip Stripe No. of Paint Applications	1
Skip Stripe No. of Stripes	4

**Pay Items**

Pay item	Description	Quantity Unit	Unit Price	Extended Amount
706-1-1	RAISED PAVMT MARK, TYPE B W/O FINAL SURF	182.00 EA	\$3.58	\$651.56
710-11-101	PAINTED PAVT MARK,STD,WHITE,SOLID,6"	1.08 GM	\$1,080.33	\$1,166.76
710-11-131	PAINTED PAVT MARK,STD,WHITE,SKIP, 6"	1.08 GM	\$460.80	\$497.66
711-15-101	THERMOPLASTIC, STD-OP, WHITE, SOLID, 6"	1.08 GM	\$4,966.76	\$5,364.10
711-15-131	THERMOPLASTIC, STD-OP, WHITE, SKIP, 6"	1.08 GM	\$1,845.33	\$1,992.96
711-15-201	THERMOPLASTIC, STD-OP,YELLOW, SOLID, 6"	1.08 GM	\$4,988.35	\$5,387.42

**Peripherals Subcomponent**

Description	Value
Off Road Bike Path(s)	0
Off Road Bike Path Width L/R	0.00 / 0.00
Bike Path Structural Spread Rate	0
Noise Barrier Wall Length	0.00
Noise Barrier Wall Begin Height	0.00
Noise Barrier Wall End Height	0.00

**Pay Items**

Pay item	Description	Quantity Unit	Unit Price	Extended Amount
521-72-40	SHLDR CONC BARRIER,38" OR 44" HEIGHT	5,702.00 LF	\$306.25	\$1,746,237.50
550-10-120	FENCING, TYPE A, 5.1-6.0, STANDARD	2,840.00 LF	\$9.26	\$26,298.40

**Roadway Component Total** \$5,342,591.54

**SHOULDER COMPONENT**

**User Input Data**

Description	Value
Total Outside Shoulder Width L/R	22.00 / 22.00
Total Outside Shoulder Perf. Turf Width L/R	0.00 / 0.00
Paved Outside Shoulder Width L/R	22.00 / 22.00
Structural Spread Rate	220
Friction Course Spread Rate	80
Total Width (T) / 8" Overlap (O)	0
Rumble Strips 1/2No. of Sides	2

**Pay Items**

Pay item	Description	Quantity Unit	Unit Price	Extended Amount
285-705	OPTIONAL BASE,BASE GROUP 05	7,045.32 SY	\$40.53	\$285,546.82
334-1-13	SUPERPAVE ASPHALTIC CONC, TRAFFIC C	763.53 TN	\$126.72	\$96,754.52
337-7-25	ASPH CONC FC,INC BIT,FC-5,PG76-22	8.33 TN	\$159.94	\$1,332.30
546-72-1	GROUND-IN RUMBLE STRIPS, 16"	0.54 GM	\$881.71	\$476.12

**Erosion Control****Pay Items**

Pay item	Description	Quantity Unit	Unit Price	Extended Amount
104-10-3	SEDIMENT BARRIER	3,691.46 LF	\$1.20	\$4,429.75
104-11	FLOATING TURBIDITY BARRIER	67.22 LF	\$9.49	\$637.92
104-12	STAKED TURBIDITY BARRIER- NYL REINF PVC	67.22 LF	\$4.44	\$298.46
104-15	SOIL TRACKING PREVENTION DEVICE	1.00 EA	\$2,988.11	\$2,988.11
104-18	INLET PROTECTION SYSTEM	2.00 EA	\$88.37	\$176.74
107-1	LITTER REMOVAL	6.52 AC	\$20.76	\$135.36
107-2	MOWING	6.52 AC	\$46.89	\$305.72
<b>Shoulder Component Total</b>				<b>\$393,081.82</b>

**MEDIAN COMPONENT****User Input Data**

Description	Value
Total Median Width	72.00
Performance Turf Width	61.50
Total Median Shoulder Width L/R	20.00 / 20.00
Paved Median Shoulder Width L/R	20.00 / 20.00
Structural Spread Rate	220
Friction Course Spread Rate	80
Total Width (T) / 8" Overlap (O)	0
Rumble Strips i <sub>l</sub> ½No. of Sides	2

**Pay Items**

Pay item	Description	Quantity Unit	Unit Price	Extended Amount
285-705	OPTIONAL BASE,BASE GROUP 05	6,414.30 SY	\$40.53	\$259,971.58
334-1-53	SUPERPAVE ASPH CONC, TRAF C, PG76-22	694.12 TN	\$127.05	\$88,187.95
337-7-25	ASPH CONC FC,INC BIT,FC- 5,PG76-22	8.33 TN	\$159.94	\$1,332.30
521-72-40	SHLDR CONC BARRIER,38" OR 44" HEIGHT	5,680.00 LF	\$306.25	\$1,739,500.00
546-72-1	GROUND-IN RUMBLE STRIPS, 16"	1.00 GM	\$881.71	\$881.71
570-1-2	PERFORMANCE TURF, SOD	9,701.91 SY	\$4.09	\$39,680.81
<b>Median Component Total</b>				<b>\$2,129,554.35</b>

**DRAINAGE COMPONENT****Pay Items**

Pay item	Description	Quantity Unit	Unit Price	Extended Amount
425-1-551	INLETS, DT BOT, TYPE E, <10'	2.00 EA	\$13,191.95	\$26,383.90
430-174-124	PIPE CULV, OPT MATL, ROUND,24"SD	216.00 LF	\$126.21	\$27,261.36
430-175-124	PIPE CULV, OPT MATL, ROUND, 24"S/CD	96.00 LF	\$128.82	\$12,366.72
430-175-136	PIPE CULV, OPT MATL, ROUND, 36"S/CD	80.00 LF	\$342.26	\$27,380.80
430-984-129	MITERED END SECT, OPTIONAL RD, 24" SD	11.00 EA	\$2,253.96	\$24,793.56
524-1-1	CONCRETE DITCH PAVT, NR, 3"	537.80 SY	\$218.44	\$117,477.03
570-1-1	PERFORMANCE TURF	189.31 SY	\$3.19	\$603.90



**X-Items**

Pay item	Description	Quantity Unit	Unit Price	Extended Amount
425-1-921	INLETS, ADJACENT BARRIER, <=10'	50.00 EA	\$5,906.88	\$295,344.00
<b>Drainage Component Total</b>				<b>\$531,611.27</b>

**SIGNING COMPONENT****Pay Items**

Pay item	Description	Quantity Unit	Unit Price	Extended Amount
700-1-11	SINGLE POST SIGN, F&I GM, <12 SF	1.00 AS	\$380.22	\$380.22
700-1-12	SINGLE POST SIGN, F&I GM, 12-20 SF	7.00 AS	\$1,503.18	\$10,522.26
700-2-14	MULTI- POST SIGN, F&I GM, 31-50 SF	1.00 AS	\$5,637.01	\$5,637.01
700-2-15	MULTI- POST SIGN, F&I GM, 51-100 SF	2.00 AS	\$7,713.11	\$15,426.22

**X-Items**

Pay item	Description	Quantity Unit	Unit Price	Extended Amount
700-4-114	OH STATIC SIGN STR, F&I, C 41-50 FT	1.00 EA	\$94,981.18	\$94,981.18
700-4-127	OH STATIC SIGN STR, F&I, S 151-200 FT	1.00 EA	\$211,285.18	\$211,285.18
<b>Signing Component Total</b>				<b>\$338,232.07</b>

**INTELLIGENT TRAFFIC SYSTEM (ITS) COMPONENT****Description of Work****EX-Items**

Pay item	Description	Quantity Unit	Unit Price	Extended Amount
000-000	GENERAL ITS <b>Comment:</b> General ITS.	1,420.00 LF	\$70.00	\$99,400.00
<b>Intelligent Traffic System (ITS) Component Total</b>				<b>\$99,400.00</b>

**LIGHTING COMPONENT****Rural Lighting Subcomponent**

Description	Value
Multiplier (Number of Poles)	30

**Pay Items**

Pay item	Description	Quantity Unit	Unit Price	Extended Amount
630-2-11	CONDUIT, F& I, OPEN TRENCH	6,000.00 LF	\$9.76	\$58,560.00
635-2-11	PULL & SPLICE BOX, F&I, 13" x 24"	30.00 EA	\$767.98	\$23,039.40
715-1-13	LIGHTING CONDUCTORS, F&I, INSUL, NO.4-2	18,000.00 LF	\$2.62	\$47,160.00
715-4-14	LIGHT POLE COMPLETE, F&I-STD, 45'	30.00 EA	\$7,063.23	\$211,896.90
715-500-1	POLE CABLE DIST SYS, CONVENTIONAL	30.00 EA	\$621.64	\$18,649.20

**Subcomponent Total** \$359,305.50

**Lighting Component Total** \$359,305.50

---

**LANDSCAPING COMPONENT**

**User Input Data**

<b>Description</b>	<b>Value</b>
Cost %	2.00
Component Detail	N

**Landscaping Component Total** \$167,936.78

---

**Sequence 37 Total** \$12,587,072.24

---

Sequence: 38 NDR - New Construction, Divided, Rural

Net Length: 0.579 MI  
3,055 LF

Description: I-4 Mainline: 3-Lanes EB GUL, 2-Lanes EB EL, 3-Lanes WB GUL, 2-Lanes WB EL. I-4 C-D  
Roads: 3-Lane EB, 2-Lane WB

**EARTHWORK COMPONENT**

**User Input Data**

Description	Value
Standard Clearing and Grubbing Limits L/R	248.00 / 214.00
Incidental Clearing and Grubbing Area	0.00
Alignment Number	1
Distance	0.580
Top of Structural Course For Begin Section	105.00
Top of Structural Course For End Section	105.00
Horizontal Elevation For Begin Section	100.00
Horizontal Elevation For End Section	100.00
Front Slope L/R	6 to 1 / 6 to 1
Median Slope L/R	6 to 1 / 6 to 1
Median Shoulder Cross Slope L/R	5.00 % / 5.00 %
Outside Shoulder Cross Slope L/R	6.00 % / 6.00 %
Roadway Cross Slope L/R	2.00 % / 2.00 %

**Pay Items**

Pay item	Description	Quantity Unit	Unit Price	Extended Amount
110-1-1	CLEARING & GRUBBING	32.42 AC	\$21,000.00	\$680,820.00
120-6	EMBANKMENT	100,684.91 CY	\$20.88	\$2,102,300.92
<b>Earthwork Component Total</b>				<b>\$2,783,120.92</b>

**ROADWAY COMPONENT**

**User Input Data**

Description	Value
Number of Lanes	6
Roadway Pavement Width L/R	84.00 / 96.00
Structural Spread Rate	440
Friction Course Spread Rate	80

**Pay Items**

Pay item	Description	Quantity Unit	Unit Price	Extended Amount
160-4	TYPE B STABILIZATION	88,255.79 SY	\$11.66	\$1,029,062.51
285-712	OPTIONAL BASE,BASE GROUP 12	61,548.23 SY	\$73.16	\$4,502,868.51
334-1-53	SUPERPAVE ASPH CONC, TRAF C, PG76-22	13,442.04 TN	\$127.05	\$1,707,811.18
337-7-25	ASPH CONC FC,INC BIT,FC-5,PG76-22	2,444.01 TN	\$159.94	\$390,894.96

**X-Items**

Pay item	Description	Quantity Unit	Unit Price	Extended Amount
546-72-1	GROUND-IN RUMBLE STRIPS, 16"	5.60 GM	\$881.71	\$4,937.58
<b>Comment:</b> Express Lane and Median Rumble Strips				

**Pavement Marking Subcomponent**

Description	Value
Include Thermo/Tape/Other	Y
Pavement Type	Asphalt

Solid Stripe No. of Paint Applications	1
Solid Stripe No. of Stripes	4
Skip Stripe No. of Paint Applications	1
Skip Stripe No. of Stripes	4

**Pay Items**

Pay item	Description	Quantity Unit	Unit Price	Extended Amount
706-1-1	RAISED PAVMT MARK, TYPE B W/O FINAL SURF	391.00 EA	\$3.58	\$1,399.78
710-11-101	PAINTED PAVT MARK,STD,WHITE,SOLID,6"	2.31 GM	\$1,080.33	\$2,495.56
710-11-131	PAINTED PAVT MARK,STD,WHITE,SKIP, 6"	2.31 GM	\$460.80	\$1,064.45
711-15-101	THERMOPLASTIC, STD-OP, WHITE, SOLID, 6"	2.31 GM	\$4,966.76	\$11,473.22
711-15-131	THERMOPLASTIC, STD-OP, WHITE, SKIP, 6"	2.31 GM	\$1,845.33	\$4,262.71
711-15-201	THERMOPLASTIC, STD-OP,YELLOW, SOLID, 6"	2.31 GM	\$4,988.35	\$11,523.09

**Peripherals Subcomponent**

Description	Value
Off Road Bike Path(s)	0
Off Road Bike Path Width L/R	0.00 / 0.00
Bike Path Structural Spread Rate	0
Noise Barrier Wall Length	0.00
Noise Barrier Wall Begin Height	0.00
Noise Barrier Wall End Height	0.00

**Pay Items**

Pay item	Description	Quantity Unit	Unit Price	Extended Amount
521-72-40	SHLDR CONC BARRIER,38" OR 44" HEIGHT	21,440.00 LF	\$306.25	\$6,566,000.00
550-10-120	FENCING, TYPE A, 5.1-6.0, STANDARD	6,110.00 LF	\$9.26	\$56,578.60
<b>Roadway Component Total</b>				<b>\$14,290,372.15</b>

**SHOULDER COMPONENT**

**User Input Data**

Description	Value
Total Outside Shoulder Width L/R	20.00 / 20.00
Total Outside Shoulder Perf. Turf Width L/R	0.00 / 0.00
Paved Outside Shoulder Width L/R	20.00 / 20.00
Structural Spread Rate	220
Friction Course Spread Rate	80
Total Width (T) / 8" Overlap (O)	0
Rumble Strips 1/2No. of Sides	2

**Pay Items**

Pay item	Description	Quantity Unit	Unit Price	Extended Amount
285-705	OPTIONAL BASE,BASE GROUP 05	13,801.85 SY	\$40.53	\$559,388.98
334-1-13	SUPERPAVE ASPHALTIC CONC, TRAFFIC C	1,493.56 TN	\$126.72	\$189,263.92
337-7-25	ASPH CONC FC,INC BIT,FC-5,PG76-22	17.92 TN	\$159.94	\$2,866.12
546-72-1	GROUND-IN RUMBLE STRIPS, 16"	1.16 GM	\$881.71	\$1,022.78

**X-Items**

Pay item	Description	Quantity Unit	Unit Price	Extended Amount
521-8-7	CONC BARRIER, W/JUNCT SL, 36 SS	3,000.00 LF	\$303.07	\$909,210.00

**Erosion Control****Pay Items**

Pay item	Description	Quantity Unit	Unit Price	Extended Amount
104-10-3	SEDIMENT BARRIER	7,943.02 LF	\$1.20	\$9,531.62
104-11	FLOATING TURBIDITY BARRIER	144.65 LF	\$9.49	\$1,372.73
104-12	STAKED TURBIDITY BARRIER-NYL REINF PVC	144.65 LF	\$4.44	\$642.25
104-15	SOIL TRACKING PREVENTION DEVICE	1.00 EA	\$2,988.11	\$2,988.11
104-18	INLET PROTECTION SYSTEM	4.00 EA	\$88.37	\$353.48
107-1	LITTER REMOVAL	14.03 AC	\$20.76	\$291.26
107-2	MOWING	14.03 AC	\$46.89	\$657.87

**Shoulder Component Total**

\$1,677,589.12

**MEDIAN COMPONENT****User Input Data**

Description	Value
Total Median Width	72.00
Performance Turf Width	61.50
Total Median Shoulder Width L/R	20.00 / 20.00
Paved Median Shoulder Width L/R	20.00 / 20.00
Structural Spread Rate	220
Friction Course Spread Rate	80
Total Width (T) / 8" Overlap (O)	0
Rumble Strips 1/2 No. of Sides	2

**Pay Items**

Pay item	Description	Quantity Unit	Unit Price	Extended Amount
285-705	OPTIONAL BASE, BASE GROUP 05	13,801.85 SY	\$40.53	\$559,388.98
334-1-53	SUPERPAVE ASPH CONC, TRAF C, PG76-22	1,493.56 TN	\$127.05	\$189,756.80
337-7-25	ASPH CONC FC, INC BIT, FC-5, PG76-22	17.92 TN	\$159.94	\$2,866.12
546-72-1	GROUND-IN RUMBLE STRIPS, 16"	1.00 GM	\$881.71	\$881.71
570-1-2	PERFORMANCE TURF, SOD	20,875.89 SY	\$4.09	\$85,382.39

**Median Component Total**

\$838,276.00

**DRAINAGE COMPONENT****Pay Items**

Pay item	Description	Quantity Unit	Unit Price	Extended Amount
425-1-551	INLETS, DT BOT, TYPE E, <10'	4.00 EA	\$13,191.95	\$52,767.80
430-174-124	PIPE CULV, OPT MATL, ROUND, 24"SD	464.00 LF	\$126.21	\$58,561.44
430-175-124	PIPE CULV, OPT MATL, ROUND, 24"S/CD	200.00 LF	\$128.82	\$25,764.00
430-175-136	PIPE CULV, OPT MATL, ROUND, 36"S/CD	176.00 LF	\$342.26	\$60,237.76

430-984-129	MITERED END SECT, OPTIONAL RD, 24" SD	24.00 EA	\$2,253.96	\$54,095.04
524-1-1	CONCRETE DITCH PAVT, NR, 3"	1,157.20 SY	\$218.44	\$252,778.77
570-1-1	PERFORMANCE TURF	407.33 SY	\$3.19	\$1,299.38

**X-Items**

Pay item	Description	Quantity Unit	Unit Price	Extended Amount
425-1-921	INLETS, ADJACENT BARRIER, <=10'	123.00 EA	\$5,906.88	\$726,546.24

**Drainage Component Total** \$1,232,050.43

**SIGNING COMPONENT**

**Pay Items**

Pay item	Description	Quantity Unit	Unit Price	Extended Amount
700-1-11	SINGLE POST SIGN, F&I GM, <12 SF	2.00 AS	\$380.22	\$760.44
700-1-12	SINGLE POST SIGN, F&I GM, 12-20 SF	14.00 AS	\$1,503.18	\$21,044.52
700-2-14	MULTI- POST SIGN, F&I GM, 31-50 SF	2.00 AS	\$5,637.01	\$11,274.02
700-2-15	MULTI- POST SIGN, F&I GM, 51-100 SF	4.00 AS	\$7,713.11	\$30,852.44

**X-Items**

Pay item	Description	Quantity Unit	Unit Price	Extended Amount
700-4-114	OH STATIC SIGN STR, F&I, C 41-50 FT	2.00 EA	\$94,981.18	\$189,962.36
700-4-127	OH STATIC SIGN STR, F&I, S 151-200 FT	1.00 EA	\$211,285.18	\$211,285.18

**Signing Component Total** \$465,178.96

**INTELLIGENT TRAFFIC SYSTEM (ITS) COMPONENT**

**Description of Work**

**EX-Items**

Pay item	Description	Quantity Unit	Unit Price	Extended Amount
000-000	GENERAL ITS Comment: General ITS.	3,055.00 LF	\$70.00	\$213,850.00

**Intelligent Traffic System (ITS) Component Total** \$213,850.00

**LIGHTING COMPONENT**

**Rural Lighting Subcomponent**

Description	Value
Multiplier (Number of Poles)	65

**Pay Items**

Pay item	Description	Quantity Unit	Unit Price	Extended Amount
630-2-11	CONDUIT, F& I, OPEN TRENCH	13,000.00 LF	\$9.76	\$126,880.00
635-2-11	PULL & SPLICE BOX, F&I, 13" x 24"	65.00 EA	\$767.98	\$49,918.70
715-1-13	LIGHTING CONDUCTORS, F&I, INSUL, NO.4-2	39,000.00 LF	\$2.62	\$102,180.00

715-4-14	LIGHT POLE COMPLETE, F&I-STD, 45'	65.00 EA	\$7,063.23	\$459,109.95
715-500-1	POLE CABLE DIST SYS, CONVENTIONAL	65.00 EA	\$621.64	\$40,406.60
	<b>Subcomponent Total</b>			\$778,495.25
	<b>Lighting Component Total</b>			\$778,495.25

---

**LANDSCAPING COMPONENT**

**User Input Data**

Description	Value
Cost %	2.00
Component Detail	N

**Landscaping Component Total** \$360,765.75

---

**RETAINING WALLS COMPONENT**

**Retaining Wall 1**

Description	Value
Length	3,000.00
Begin height	17.50
End Height	17.50
Multiplier	2

**Pay Items**

Pay item	Description	Quantity	Unit	Unit Price	Extended Amount
548-12	RET WALL SYSTEM, PERM, EX BARRIER	105,000.00	SF	\$36.17	\$3,797,850.00
	<b>Retaining Walls Component Total</b>				\$3,797,850.00

---

**Sequence 38 Total** \$26,437,548.58

---

Sequence: 39 NDR - New Construction, Divided, Rural

Net Length: 0.530 MI  
2,798 LF

Description: I-4 Mainline: 4-Lanes AVG EB GUL, 4-Lanes WB GUL, 2-Lanes WB EL. 2-Lanes EB EL Bridge  
Over EB GUL Included in Sequence 40.

**EARTHWORK COMPONENT**

**User Input Data**

Description	Value
Standard Clearing and Grubbing Limits L/R	230.00 / 214.00
Incidental Clearing and Grubbing Area	0.00
Alignment Number	1
Distance	0.530
Top of Structural Course For Begin Section	105.00
Top of Structural Course For End Section	105.00
Horizontal Elevation For Begin Section	100.00
Horizontal Elevation For End Section	100.00
Front Slope L/R	6 to 1 / 6 to 1
Median Slope L/R	6 to 1 / 6 to 1
Median Shoulder Cross Slope L/R	5.00 % / 5.00 %
Outside Shoulder Cross Slope L/R	6.00 % / 6.00 %
Roadway Cross Slope L/R	2.00 % / 2.00 %

**Pay Items**

Pay item	Description	Quantity Unit	Unit Price	Extended Amount
110-1-1	CLEARING & GRUBBING	28.52 AC	\$21,000.00	\$598,920.00
120-6	EMBANKMENT	112,290.46 CY	\$20.88	\$2,344,624.80
<b>Earthwork Component Total</b>				<b>\$2,943,544.80</b>

**ROADWAY COMPONENT**

**User Input Data**

Description	Value
Number of Lanes	6
Roadway Pavement Width L/R	60.00 / 48.00
Structural Spread Rate	440
Friction Course Spread Rate	80

**Pay Items**

Pay item	Description	Quantity Unit	Unit Price	Extended Amount
160-4	TYPE B STABILIZATION	59,699.20 SY	\$11.66	\$696,092.67
285-712	OPTIONAL BASE,BASE GROUP 12	33,991.23 SY	\$73.16	\$2,486,798.39
334-1-53	SUPERPAVE ASPH CONC, TRAF C, PG76-22	7,387.78 TN	\$127.05	\$938,617.45
337-7-25	ASPH CONC FC,INC BIT,FC-5,PG76-22	1,343.23 TN	\$159.94	\$214,836.21

**X-Items**

Pay item	Description	Quantity Unit	Unit Price	Extended Amount
546-72-1	GROUND-IN RUMBLE STRIPS, 16"	2.12 GM	\$881.71	\$1,869.23
	<b>Comment:</b> Express Lane Rumble Strips			

**Pavement Marking Subcomponent**

Description	Value
Include Thermo/Tape/Other	Y
Pavement Type	Asphalt



Solid Stripe No. of Paint Applications	1
Solid Stripe No. of Stripes	4
Skip Stripe No. of Paint Applications	1
Skip Stripe No. of Stripes	4

**Pay Items**

Pay item	Description	Quantity Unit	Unit Price	Extended Amount
706-1-1	RAISED PAVMT MARK, TYPE B W/O FINAL SURF	358.00 EA	\$3.58	\$1,281.64
710-11-101	PAINTED PAVT MARK,STD,WHITE,SOLID,6"	2.12 GM	\$1,080.33	\$2,290.30
710-11-131	PAINTED PAVT MARK,STD,WHITE,SKIP, 6"	2.12 GM	\$460.80	\$976.90
711-15-101	THERMOPLASTIC, STD-OP, WHITE, SOLID, 6"	2.12 GM	\$4,966.76	\$10,529.53
711-15-131	THERMOPLASTIC, STD-OP, WHITE, SKIP, 6"	2.12 GM	\$1,845.33	\$3,912.10
711-15-201	THERMOPLASTIC, STD-OP,YELLOW, SOLID, 6"	2.12 GM	\$4,988.35	\$10,575.30

**Peripherals Subcomponent**

Description	Value
Off Road Bike Path(s)	0
Off Road Bike Path Width L/R	0.00 / 0.00
Bike Path Structural Spread Rate	0
Noise Barrier Wall Length	0.00
Noise Barrier Wall Begin Height	0.00
Noise Barrier Wall End Height	0.00

**Pay Items**

Pay item	Description	Quantity Unit	Unit Price	Extended Amount
521-72-40	SHLDR CONC BARRIER,38" OR 44" HEIGHT	15,438.00 LF	\$306.25	\$4,727,887.50
550-10-120	FENCING, TYPE A, 5.1-6.0, STANDARD	5,546.00 LF	\$9.26	\$51,355.96
<b>Roadway Component Total</b>				<b>\$9,147,023.18</b>

**SHOULDER COMPONENT**

**User Input Data**

Description	Value
Total Outside Shoulder Width L/R	22.00 / 22.00
Total Outside Shoulder Perf. Turf Width L/R	0.00 / 0.00
Paved Outside Shoulder Width L/R	22.00 / 22.00
Structural Spread Rate	220
Friction Course Spread Rate	80
Total Width (T) / 8" Overlap (O)	0
Rumble Strips 1/2No. of Sides	2

**Pay Items**

Pay item	Description	Quantity Unit	Unit Price	Extended Amount
285-705	OPTIONAL BASE,BASE GROUP 05	13,886.28 SY	\$40.53	\$562,810.93
334-1-13	SUPERPAVE ASPHALTIC CONC, TRAFFIC C	1,504.92 TN	\$126.72	\$190,703.46
337-7-25	ASPH CONC FC,INC BIT,FC-5,PG76-22	16.42 TN	\$159.94	\$2,626.21
546-72-1	GROUND-IN RUMBLE STRIPS, 16"	1.06 GM	\$881.71	\$934.61

**X-Items**

Pay item	Description	Quantity Unit	Unit Price	Extended Amount
521-8-7	CONC BARRIER, W/JUNCT SL, 36 SS	1,200.00 LF	\$303.07	\$363,684.00

**Erosion Control****Pay Items**

Pay item	Description	Quantity Unit	Unit Price	Extended Amount
104-10-3	SEDIMENT BARRIER	7,275.84 LF	\$1.20	\$8,731.01
104-11	FLOATING TURBIDITY BARRIER	132.50 LF	\$9.49	\$1,257.42
104-12	STAKED TURBIDITY BARRIER-NYL REINF PVC	132.50 LF	\$4.44	\$588.30
104-15	SOIL TRACKING PREVENTION DEVICE	1.00 EA	\$2,988.11	\$2,988.11
104-18	INLET PROTECTION SYSTEM	4.00 EA	\$88.37	\$353.48
107-1	LITTER REMOVAL	12.85 AC	\$20.76	\$266.77
107-2	MOWING	12.85 AC	\$46.89	\$602.54
<b>Shoulder Component Total</b>				<b>\$1,135,546.85</b>

**MEDIAN COMPONENT****User Input Data**

Description	Value
Total Median Width	167.50
Performance Turf Width	127.75
Total Median Shoulder Width L/R	20.00 / 20.00
Paved Median Shoulder Width L/R	20.00 / 20.00
Structural Spread Rate	220
Friction Course Spread Rate	80
Total Width (T) / 8" Overlap (O)	0
Rumble Strips 1/2 No. of Sides	2

**Pay Items**

Pay item	Description	Quantity Unit	Unit Price	Extended Amount
285-705	OPTIONAL BASE, BASE GROUP 05	12,642.55 SY	\$40.53	\$512,402.55
334-1-53	SUPERPAVE ASPH CONC, TRAF C, PG76-22	1,368.11 TN	\$127.05	\$173,818.38
337-7-25	ASPH CONC FC, INC BIT, FC-5, PG76-22	16.42 TN	\$159.94	\$2,626.21
546-72-1	GROUND-IN RUMBLE STRIPS, 16"	1.00 GM	\$881.71	\$881.71
570-1-2	PERFORMANCE TURF, SOD	39,721.73 SY	\$4.09	\$162,461.88
<b>Median Component Total</b>				<b>\$852,190.73</b>

**DRAINAGE COMPONENT****Pay Items**

Pay item	Description	Quantity Unit	Unit Price	Extended Amount
425-1-551	INLETS, DT BOT, TYPE E, <10'	4.00 EA	\$13,191.95	\$52,767.80
430-174-124	PIPE CULV, OPT MATL, ROUND, 24"SD	424.00 LF	\$126.21	\$53,513.04
430-175-124	PIPE CULV, OPT MATL, ROUND, 24"S/CD	184.00 LF	\$128.82	\$23,702.88
430-175-136	PIPE CULV, OPT MATL, ROUND, 36"S/CD	160.00 LF	\$342.26	\$54,761.60

430-984-129	MITERED END SECT, OPTIONAL RD, 24" SD	22.00 EA	\$2,253.96	\$49,587.12
524-1-1	CONCRETE DITCH PAVT, NR, 3"	1,060.00 SY	\$218.44	\$231,546.40
570-1-1	PERFORMANCE TURF	373.12 SY	\$3.19	\$1,190.25

**X-Items**

Pay item	Description	Quantity Unit	Unit Price	Extended Amount
425-1-921	INLETS, ADJACENT BARRIER, <=10'	84.00 EA	\$5,906.88	\$496,177.92
<b>Drainage Component Total</b>				<b>\$963,247.01</b>

**SIGNING COMPONENT**

**Pay Items**

Pay item	Description	Quantity Unit	Unit Price	Extended Amount
700-1-11	SINGLE POST SIGN, F&I GM, <12 SF	2.00 AS	\$380.22	\$760.44
700-1-12	SINGLE POST SIGN, F&I GM, 12-20 SF	13.00 AS	\$1,503.18	\$19,541.34
700-2-14	MULTI- POST SIGN, F&I GM, 31-50 SF	2.00 AS	\$5,637.01	\$11,274.02
700-2-15	MULTI- POST SIGN, F&I GM, 51-100 SF	4.00 AS	\$7,713.11	\$30,852.44

**X-Items**

Pay item	Description	Quantity Unit	Unit Price	Extended Amount
700-4-114	OH STATIC SIGN STR, F&I, C 41-50 FT	2.00 EA	\$94,981.18	\$189,962.36
700-4-127	OH STATIC SIGN STR, F&I, S 151-200 FT	1.00 EA	\$211,285.18	\$211,285.18
<b>Signing Component Total</b>				<b>\$463,675.78</b>

**INTELLIGENT TRAFFIC SYSTEM (ITS) COMPONENT**

**Description of Work**

**EX-Items**

Pay item	Description	Quantity Unit	Unit Price	Extended Amount
000-000	GENERAL ITS Comment: General ITS.	2,773.00 LF	\$70.00	\$194,110.00
<b>Intelligent Traffic System (ITS) Component Total</b>				<b>\$194,110.00</b>

**LIGHTING COMPONENT**

**Rural Lighting Subcomponent**

Description	Value			
Multiplier (Number of Poles)	59			
Pay Items	Extended Amount			
Pay item	Description	Quantity Unit	Unit Price	Extended Amount
630-2-11	CONDUIT, F& I, OPEN TRENCH	11,800.00 LF	\$9.76	\$115,168.00
635-2-11	PULL & SPLICE BOX, F&I, 13" x 24"	59.00 EA	\$767.98	\$45,310.82
715-1-13	LIGHTING CONDUCTORS, F&I, INSUL, NO.4-2	35,400.00 LF	\$2.62	\$92,748.00

715-4-14	LIGHT POLE COMPLETE, F&I-STD, 45'	59.00 EA	\$7,063.23	\$416,730.57
715-500-1	POLE CABLE DIST SYS, CONVENTIONAL	59.00 EA	\$621.64	\$36,676.76
	<b>Subcomponent Total</b>			\$706,634.15
	<b>Lighting Component Total</b>			\$706,634.15

---

**LANDSCAPING COMPONENT**

**User Input Data**

<b>Description</b>	<b>Value</b>
Cost %	2.00
Component Detail	N

**Landscaping Component Total** \$241,960.16

---

**RETAINING WALLS COMPONENT**

**Retaining Wall 1**

<b>Description</b>	<b>Value</b>
Length	1,200.00
Begin height	17.50
End Height	17.50
Multiplier	2

**Pay Items**

<b>Pay item</b>	<b>Description</b>	<b>Quantity</b>	<b>Unit</b>	<b>Unit Price</b>	<b>Extended Amount</b>
548-12	RET WALL SYSTEM, PERM, EX BARRIER	42,000.00	SF	\$36.17	\$1,519,140.00
	<b>Retaining Walls Component Total</b>				\$1,519,140.00

---

**Sequence 39 Total** \$18,167,072.66

---

Sequence: 40 NDR - New Construction, Divided, Rural

Net Length: 0.880 MI  
4,645 LF

Description: I-4 Mainline: 5-Lanes EB GUL+1 AUX for 1/3 Distance, 4-Lanes WB GUL, 2-Lanes WB EL. 2-Lanes EB EL Bridge Over EB GUL and EB and WB Bridges over Reedy Creek are included.

### EARTHWORK COMPONENT

#### User Input Data

Description	Value
Standard Clearing and Grubbing Limits L/R	354.00 / 214.00
Incidental Clearing and Grubbing Area	0.00
Alignment Number	1
Distance	0.880
Top of Structural Course For Begin Section	105.00
Top of Structural Course For End Section	105.00
Horizontal Elevation For Begin Section	100.00
Horizontal Elevation For End Section	100.00
Front Slope L/R	6 to 1 / 6 to 1
Median Slope L/R	6 to 1 / 6 to 1
Median Shoulder Cross Slope L/R	5.00 % / 5.00 %
Outside Shoulder Cross Slope L/R	6.00 % / 6.00 %
Roadway Cross Slope L/R	2.00 % / 2.00 %

#### Pay Items

Pay item	Description	Quantity	Unit	Unit Price	Extended Amount
110-1-1	CLEARING & GRUBBING	60.59	AC	\$21,000.00	\$1,272,390.00
120-6	EMBANKMENT	200,142.82	CY	\$20.88	\$4,178,982.08
<b>Earthwork Component Total</b>					<b>\$5,451,372.08</b>

### ROADWAY COMPONENT

#### User Input Data

Description	Value
Number of Lanes	6
Roadway Pavement Width L/R	76.00 / 64.33
Structural Spread Rate	440
Friction Course Spread Rate	80

#### Pay Items

Pay item	Description	Quantity	Unit	Unit Price	Extended Amount
160-4	TYPE B STABILIZATION	115,774.62	SY	\$11.66	\$1,349,932.07
285-712	OPTIONAL BASE,BASE GROUP 12	73,104.24	SY	\$73.16	\$5,348,306.20
334-1-53	SUPERPAVE ASPH CONC, TRAF C, PG76-22	15,933.06	TN	\$127.05	\$2,024,295.27
337-7-25	ASPH CONC FC,INC BIT,FC-5,PG76-22	2,896.92	TN	\$159.94	\$463,333.38

#### X-Items

Pay item	Description	Quantity	Unit	Unit Price	Extended Amount
546-72-1	GROUND-IN RUMBLE STRIPS, 16"	3.76	GM	\$881.71	\$3,315.23
<b>Comment:</b> Express Lane Rumble Strips					

#### Pavement Marking Subcomponent

Description	Value
Include Thermo/Tape/Other	Y
Pavement Type	Asphalt

Solid Stripe No. of Paint Applications	1
Solid Stripe No. of Stripes	4
Skip Stripe No. of Paint Applications	1
Skip Stripe No. of Stripes	4

#### Pay Items

Pay item	Description	Quantity Unit	Unit Price	Extended Amount
706-1-1	RAISED PAVMT MARK, TYPE B W/O FINAL SURF	594.00 EA	\$3.58	\$2,126.52
710-11-101	PAINTED PAVT MARK,STD,WHITE,SOLID,6"	3.52 GM	\$1,080.33	\$3,802.76
710-11-131	PAINTED PAVT MARK,STD,WHITE,SKIP, 6"	3.52 GM	\$460.80	\$1,622.02
711-15-101	THERMOPLASTIC, STD-OP, WHITE, SOLID, 6"	3.52 GM	\$4,966.76	\$17,483.00
711-15-131	THERMOPLASTIC, STD-OP, WHITE, SKIP, 6"	3.52 GM	\$1,845.33	\$6,495.56
711-15-201	THERMOPLASTIC, STD-OP,YELLOW, SOLID, 6"	3.52 GM	\$4,988.35	\$17,558.99

#### Peripherals Subcomponent

Description	Value
Off Road Bike Path(s)	0
Off Road Bike Path Width L/R	0.00 / 0.00
Bike Path Structural Spread Rate	0
Noise Barrier Wall Length	0.00
Noise Barrier Wall Begin Height	0.00
Noise Barrier Wall End Height	0.00

#### Pay Items

Pay item	Description	Quantity Unit	Unit Price	Extended Amount
521-72-40	SHLDR CONC BARRIER,38" OR 44" HEIGHT	26,670.00 LF	\$306.25	\$8,167,687.50
550-10-120	FENCING, TYPE A, 5.1-6.0, STANDARD	9,290.00 LF	\$9.26	\$86,025.40
<b>Roadway Component Total</b>				<b>\$17,491,983.90</b>

### SHOULDER COMPONENT

#### User Input Data

Description	Value
Total Outside Shoulder Width L/R	22.00 / 22.00
Total Outside Shoulder Perf. Turf Width L/R	0.00 / 0.00
Paved Outside Shoulder Width L/R	22.00 / 22.00
Structural Spread Rate	220
Friction Course Spread Rate	80
Total Width (T) / 8" Overlap (O)	0
Rumble Strips $\frac{1}{2}$ No. of Sides	2

#### Pay Items

Pay item	Description	Quantity Unit	Unit Price	Extended Amount
285-705	OPTIONAL BASE,BASE GROUP 05	23,048.61 SY	\$40.53	\$934,160.16
334-1-13	SUPERPAVE ASPHALTIC CONC, TRAFFIC C	2,497.88 TN	\$126.72	\$316,531.35
337-7-25	ASPH CONC FC,INC BIT,FC-5,PG76-22	27.25 TN	\$159.94	\$4,358.36
546-72-1	GROUND-IN RUMBLE STRIPS, 16"	1.76 GM	\$881.71	\$1,551.81

**X-Items**

Pay item	Description	Quantity Unit	Unit Price	Extended Amount
521-8-7	CONC BARRIER, W/JUNCT SL, 36 SS	1,200.00 LF	\$303.07	\$363,684.00

**Erosion Control****Pay Items**

Pay item	Description	Quantity Unit	Unit Price	Extended Amount
104-10-3	SEDIMENT BARRIER	12,076.52 LF	\$1.20	\$14,491.82
104-11	FLOATING TURBIDITY BARRIER	219.92 LF	\$9.49	\$2,087.04
104-12	STAKED TURBIDITY BARRIER-NYL REINF PVC	219.92 LF	\$4.44	\$976.44
104-15	SOIL TRACKING PREVENTION DEVICE	1.00 EA	\$2,988.11	\$2,988.11
104-18	INLET PROTECTION SYSTEM	6.00 EA	\$88.37	\$530.22
107-1	LITTER REMOVAL	21.32 AC	\$20.76	\$442.60
107-2	MOWING	21.32 AC	\$46.89	\$999.69
<b>Shoulder Component Total</b>				<b>\$1,642,801.61</b>

**MEDIAN COMPONENT****User Input Data**

Description	Value
Total Median Width	174.00
Performance Turf Width	134.25
Total Median Shoulder Width L/R	20.00 / 20.00
Paved Median Shoulder Width L/R	20.00 / 20.00
Structural Spread Rate	220
Friction Course Spread Rate	80
Total Width (T) / 8" Overlap (O)	0
Rumble Strips 1/2 No. of Sides	2

**Pay Items**

Pay item	Description	Quantity Unit	Unit Price	Extended Amount
285-705	OPTIONAL BASE, BASE GROUP 05	20,984.25 SY	\$40.53	\$850,491.65
334-1-53	SUPERPAVE ASPH CONC, TRAF C, PG76-22	2,270.80 TN	\$127.05	\$288,505.14
337-7-25	ASPH CONC FC, INC BIT, FC-5, PG76-22	27.25 TN	\$159.94	\$4,358.36
546-72-1	GROUND-IN RUMBLE STRIPS, 16"	2.00 GM	\$881.71	\$1,763.42
570-1-2	PERFORMANCE TURF, SOD	69,285.17 SY	\$4.09	\$283,376.35
<b>Median Component Total</b>				<b>\$1,428,494.93</b>

**DRAINAGE COMPONENT****Pay Items**

Pay item	Description	Quantity Unit	Unit Price	Extended Amount
425-1-551	INLETS, DT BOT, TYPE E, <10'	6.00 EA	\$13,191.95	\$79,151.70
430-174-124	PIPE CULV, OPT MATL, ROUND, 24"SD	704.00 LF	\$126.21	\$88,851.84
430-175-124	PIPE CULV, OPT MATL, ROUND, 24"S/CD	304.00 LF	\$128.82	\$39,161.28
430-175-136	PIPE CULV, OPT MATL, ROUND, 36"S/CD	264.00 LF	\$342.26	\$90,356.64

430-984-129	MITERED END SECT, OPTIONAL RD, 24" SD	36.00 EA	\$2,253.96	\$81,142.56
524-1-1	CONCRETE DITCH PAVT, NR, 3"	1,759.40 SY	\$218.44	\$384,323.34
570-1-1	PERFORMANCE TURF	619.31 SY	\$3.19	\$1,975.60

**X-Items**

Pay item	Description	Quantity Unit	Unit Price	Extended Amount
425-1-921	INLETS, ADJACENT BARRIER, <=10'	233.00 EA	\$5,906.88	\$1,376,303.04

**Drainage Component Total** \$2,141,266.00

**SIGNING COMPONENT**

**Pay Items**

Pay item	Description	Quantity Unit	Unit Price	Extended Amount
700-1-11	SINGLE POST SIGN, F&I GM, <12 SF	2.00 AS	\$380.22	\$760.44
700-1-12	SINGLE POST SIGN, F&I GM, 12-20 SF	22.00 AS	\$1,503.18	\$33,069.96
700-2-14	MULTI- POST SIGN, F&I GM, 31-50 SF	2.00 AS	\$5,637.01	\$11,274.02
700-2-15	MULTI- POST SIGN, F&I GM, 51-100 SF	6.00 AS	\$7,713.11	\$46,278.66

**X-Items**

Pay item	Description	Quantity Unit	Unit Price	Extended Amount
700-4-114	OH STATIC SIGN STR, F&I, C 41-50 FT	3.00 EA	\$94,981.18	\$284,943.54
700-4-127	OH STATIC SIGN STR, F&I, S 151-200 FT	1.00 EA	\$211,285.18	\$211,285.18

**Signing Component Total** \$587,611.80

**INTELLIGENT TRAFFIC SYSTEM (ITS) COMPONENT**

**Description of Work**

**EX-Items**

Pay item	Description	Quantity Unit	Unit Price	Extended Amount
000-000	GENERAL ITS Comment: General ITS.	4,645.00 LF	\$70.00	\$325,150.00

**Intelligent Traffic System (ITS) Component Total** \$325,150.00

**LIGHTING COMPONENT**

**Rural Lighting Subcomponent**

Description	Value
Multiplier (Number of Poles)	98

**Pay Items**

Pay item	Description	Quantity Unit	Unit Price	Extended Amount
630-2-11	CONDUIT, F& I, OPEN TRENCH	19,600.00 LF	\$9.76	\$191,296.00
635-2-11	PULL & SPLICE BOX, F&I, 13" x 24"	98.00 EA	\$767.98	\$75,262.04
715-1-13	LIGHTING CONDUCTORS, F&I, INSUL, NO.4-2	58,800.00 LF	\$2.62	\$154,056.00



715-4-14	LIGHT POLE COMPLETE, F&I- STD, 45'	98.00 EA	\$7,063.23	\$692,196.54
715-500-1	POLE CABLE DIST SYS, CONVENTIONAL	98.00 EA	\$621.64	\$60,920.72
	<b>Subcomponent Total</b>			\$1,173,731.30
	<b>Lighting Component Total</b>			\$1,173,731.30

---

**LANDSCAPING COMPONENT**

**User Input Data**

<b>Description</b>	<b>Value</b>
Cost %	2.00
Component Detail	N

**Landscaping Component Total** \$454,090.93

---

**Sequence 40 Total** \$30,696,502.55

---

Sequence: 41 NDR - New Construction, Divided, Rural

Net Length: 0.346 MI  
1,826 LF

Description: I-4 Mainline: 3-Lanes EB GUL, 2-Lanes-EB EL, 3-Lanes WB GUL, 2-Lanes WB EL.

**EARTHWORK COMPONENT**

**User Input Data**

Description	Value
Standard Clearing and Grubbing Limits L/R	230.00 / 214.00
Incidental Clearing and Grubbing Area	0.00
Alignment Number	1
Distance	0.350
Top of Structural Course For Begin Section	105.00
Top of Structural Course For End Section	105.00
Horizontal Elevation For Begin Section	100.00
Horizontal Elevation For End Section	100.00
Front Slope L/R	6 to 1 / 6 to 1
Median Slope L/R	6 to 1 / 6 to 1
Median Shoulder Cross Slope L/R	5.00 % / 5.00 %
Outside Shoulder Cross Slope L/R	6.00 % / 6.00 %
Roadway Cross Slope L/R	2.00 % / 2.00 %

**Pay Items**

Pay item	Description	Quantity	Unit	Unit Price	Extended Amount
110-1-1	CLEARING & GRUBBING	18.62	AC	\$21,000.00	\$391,020.00
120-6	EMBANKMENT	61,064.76	CY	\$20.88	\$1,275,032.19
<b>Earthwork Component Total</b>					<b>\$1,666,052.19</b>

**ROADWAY COMPONENT**

**User Input Data**

Description	Value
Number of Lanes	6
Roadway Pavement Width L/R	64.00 / 64.00
Structural Spread Rate	440
Friction Course Spread Rate	80

**Pay Items**

Pay item	Description	Quantity	Unit	Unit Price	Extended Amount
160-4	TYPE B STABILIZATION	43,008.30	SY	\$11.66	\$501,476.78
285-712	OPTIONAL BASE,BASE GROUP 12	26,235.06	SY	\$73.16	\$1,919,356.99
334-1-53	SUPERPAVE ASPH CONC, TRAF C, PG76-22	5,712.80	TN	\$127.05	\$725,811.24
337-7-25	ASPH CONC FC,INC BIT,FC-5,PG76-22	1,038.69	TN	\$159.94	\$166,128.08

**X-Items**

Pay item	Description	Quantity	Unit	Unit Price	Extended Amount
546-72-1	GROUND-IN RUMBLE STRIPS, 16"	2.32	GM	\$881.71	\$2,045.57
<b>Comment:</b> Express Lane Rumble Strips					

**Pavement Marking Subcomponent**

Description	Value
Include Thermo/Tape/Other	Y
Pavement Type	Asphalt
Solid Stripe No. of Paint Applications	1

Solid Stripe No. of Stripes	4
Skip Stripe No. of Paint Applications	1
Skip Stripe No. of Stripes	4

**Pay Items**

Pay item	Description	Quantity Unit	Unit Price	Extended Amount
706-1-1	RAISED PAVMT MARK, TYPE B W/O FINAL SURF	233.00 EA	\$3.58	\$834.14
710-11-101	PAINTED PAVT MARK,STD,WHITE,SOLID,6"	1.38 GM	\$1,080.33	\$1,490.86
710-11-131	PAINTED PAVT MARK,STD,WHITE,SKIP, 6"	1.38 GM	\$460.80	\$635.90
711-15-101	THERMOPLASTIC, STD-OP, WHITE, SOLID, 6"	1.38 GM	\$4,966.76	\$6,854.13
711-15-131	THERMOPLASTIC, STD-OP, WHITE, SKIP, 6"	1.38 GM	\$1,845.33	\$2,546.56
711-15-201	THERMOPLASTIC, STD-OP,YELLOW, SOLID, 6"	1.38 GM	\$4,988.35	\$6,883.92

**Peripherals Subcomponent**

Description	Value
Off Road Bike Path(s)	0
Off Road Bike Path Width L/R	0.00 / 0.00
Bike Path Structural Spread Rate	0
Noise Barrier Wall Length	0.00
Noise Barrier Wall Begin Height	0.00
Noise Barrier Wall End Height	0.00

**Pay Items**

Pay item	Description	Quantity Unit	Unit Price	Extended Amount
521-72-40	SHLDR CONC BARRIER,38" OR 44" HEIGHT	16,660.00 LF	\$306.25	\$5,102,125.00
550-10-120	FENCING, TYPE A, 5.1-6.0, STANDARD	3,652.00 LF	\$9.26	\$33,817.52

**Roadway Component Total** \$8,470,006.69

**SHOULDER COMPONENT**

**User Input Data**

Description	Value
Total Outside Shoulder Width L/R	22.00 / 22.00
Total Outside Shoulder Perf. Turf Width L/R	0.00 / 0.00
Paved Outside Shoulder Width L/R	22.00 / 22.00
Structural Spread Rate	220
Friction Course Spread Rate	80
Total Width (T) / 8" Overlap (O)	0
Rumble Strips 1/2No. of Sides	2

**Pay Items**

Pay item	Description	Quantity Unit	Unit Price	Extended Amount
285-705	OPTIONAL BASE,BASE GROUP 05	9,060.14 SY	\$40.53	\$367,207.47
334-1-13	SUPERPAVE ASPHALTIC CONC, TRAFFIC C	981.89 TN	\$126.72	\$124,425.10
337-7-25	ASPH CONC FC,INC BIT,FC-5,PG76-22	10.71 TN	\$159.94	\$1,712.96
546-72-1	GROUND-IN RUMBLE STRIPS, 16"	0.69 GM	\$881.71	\$608.38

**X-Items**

Pay item	Description	Quantity	Unit	Unit Price	Extended Amount
521-8-7	CONC BARRIER, W/JUNCT SL, 36 SS	1,600.00	LF	\$303.07	\$484,912.00

**Erosion Control****Pay Items**

Pay item	Description	Quantity	Unit	Unit Price	Extended Amount
104-10-3	SEDIMENT BARRIER	4,747.14	LF	\$1.20	\$5,696.57
104-11	FLOATING TURBIDITY BARRIER	86.45	LF	\$9.49	\$820.41
104-12	STAKED TURBIDITY BARRIER-NYL REINF PVC	86.45	LF	\$4.44	\$383.84
104-15	SOIL TRACKING PREVENTION DEVICE	1.00	EA	\$2,988.11	\$2,988.11
104-18	INLET PROTECTION SYSTEM	3.00	EA	\$88.37	\$265.11
107-1	LITTER REMOVAL	8.38	AC	\$20.76	\$173.97
107-2	MOWING	8.38	AC	\$46.89	\$392.94

**Shoulder Component Total**

\$989,586.86

**MEDIAN COMPONENT****User Input Data**

Description	Value
Total Median Width	97.00
Performance Turf Width	86.50
Total Median Shoulder Width L/R	20.00 / 20.00
Paved Median Shoulder Width L/R	20.00 / 20.00
Structural Spread Rate	220
Friction Course Spread Rate	80
Total Width (T) / 8" Overlap (O)	O
Rumble Strips $i_c \frac{1}{2}$ No. of Sides	2

**Pay Items**

Pay item	Description	Quantity	Unit	Unit Price	Extended Amount
285-705	OPTIONAL BASE, BASE GROUP 05	8,248.67	SY	\$40.53	\$334,318.60
334-1-53	SUPERPAVE ASPH CONC, TRAF C, PG76-22	892.63	TN	\$127.05	\$113,408.64
337-7-25	ASPH CONC FC, INC BIT, FC-5, PG76-22	10.71	TN	\$159.94	\$1,712.96
521-1-11	MEDIAN CONC BARRIER, 38" HEIGHT	7,304.00	LF	\$316.17	\$2,309,305.68
546-72-1	GROUND-IN RUMBLE STRIPS, 16"	1.00	GM	\$881.71	\$881.71
570-1-2	PERFORMANCE TURF, SOD	17,548.20	SY	\$4.09	\$71,772.14

**Median Component Total**

\$2,831,399.73

**DRAINAGE COMPONENT****Pay Items**

Pay item	Description	Quantity	Unit	Unit Price	Extended Amount
425-1-551	INLETS, DT BOT, TYPE E, <10'	3.00	EA	\$13,191.95	\$39,575.85
430-174-124	PIPE CULV, OPT MATL, ROUND, 24"SD	280.00	LF	\$126.21	\$35,338.80
430-175-124	PIPE CULV, OPT MATL, ROUND, 24"S/CD	120.00	LF	\$128.82	\$15,458.40

430-175-136	PIPE CULV, OPT MATL, ROUND, 36"S/CD	104.00 LF	\$342.26	\$35,595.04
430-984-129	MITERED END SECT, OPTIONAL RD, 24" SD	14.00 EA	\$2,253.96	\$31,555.44
524-1-1	CONCRETE DITCH PAVT, NR, 3"	691.60 SY	\$218.44	\$151,073.10
570-1-1	PERFORMANCE TURF	243.44 SY	\$3.19	\$776.57

**X-Items**

Pay item	Description	Quantity Unit	Unit Price	Extended Amount
425-1-921	INLETS, ADJACENT BARRIER, <=10'	128.00 EA	\$5,906.88	\$756,080.64
<b>Drainage Component Total</b>				<b>\$1,065,453.84</b>

**SIGNING COMPONENT**

**Pay Items**

Pay item	Description	Quantity Unit	Unit Price	Extended Amount
700-1-11	SINGLE POST SIGN, F&I GM, <12 SF	1.00 AS	\$380.22	\$380.22
700-1-12	SINGLE POST SIGN, F&I GM, 12- 20 SF	9.00 AS	\$1,503.18	\$13,528.62
700-2-14	MULTI- POST SIGN, F&I GM, 31-50 SF	1.00 AS	\$5,637.01	\$5,637.01
700-2-15	MULTI- POST SIGN, F&I GM, 51- 100 SF	3.00 AS	\$7,713.11	\$23,139.33

**X-Items**

Pay item	Description	Quantity Unit	Unit Price	Extended Amount
700-4-114	OH STATIC SIGN STR, F&I, C 41- 50 FT	1.00 EA	\$94,981.18	\$94,981.18
700-4-127	OH STATIC SIGN STR, F&I, S 151- 200 FT	1.00 EA	\$211,285.18	\$211,285.18
<b>Signing Component Total</b>				<b>\$348,951.54</b>

**INTELLIGENT TRAFFIC SYSTEM (ITS) COMPONENT**

**Description of Work**

**EX-Items**

Pay item	Description	Quantity Unit	Unit Price	Extended Amount
000-000	GENERAL ITS <b>Comment:</b> General ITS.	1,826.00 LF	\$70.00	\$127,820.00
<b>Intelligent Traffic System (ITS) Component Total</b>				<b>\$127,820.00</b>

**LIGHTING COMPONENT**

**Rural Lighting Subcomponent**

Description	Value			
Multiplier (Number of Poles)	58			
Pay item	Description	Quantity Unit	Unit Price	Extended Amount
630-2-11	CONDUIT, F& I, OPEN TRENCH	11,600.00 LF	\$9.76	\$113,216.00
635-2-11	PULL & SPLICE BOX, F&I, 13" x 24"	58.00 EA	\$767.98	\$44,542.84

715-1-13	LIGHTING CONDUCTORS, F&I, INSUL, NO.4-2	34,800.00 LF	\$2.62	\$91,176.00
715-4-14	LIGHT POLE COMPLETE, F&I- STD, 45'	58.00 EA	\$7,063.23	\$409,667.34
715-500-1	POLE CABLE DIST SYS, CONVENTIONAL	58.00 EA	\$621.64	\$36,055.12
	<b>Subcomponent Total</b>			\$694,657.30
	<b>Lighting Component Total</b>			\$694,657.30

---

**LANDSCAPING COMPONENT**

**User Input Data**

<b>Description</b>	<b>Value</b>
Cost %	2.00
Component Detail	N

**Landscaping Component Total** \$267,128.94

---

**RETAINING WALLS COMPONENT**

**Retaining Wall 1**

<b>Description</b>	<b>Value</b>
Length	1,600.00
Begin height	17.50
End Height	17.50
Multiplier	2

**Pay Items**

<b>Pay item</b>	<b>Description</b>	<b>Quantity Unit</b>	<b>Unit Price</b>	<b>Extended Amount</b>
548-12	RET WALL SYSTEM, PERM, EX BARRIER	56,000.00 SF	\$36.17	\$2,025,520.00

**Retaining Walls Component Total** \$2,025,520.00

---

**Sequence 41 Total** \$18,486,577.09

---

# FDOT Long Range Estimating System - Production

## R3: Project Details by Sequence Report

**Project:** 446581-1-22-01

**Letting Date:** 01/2099

**Description:** PD&E FOR POINCIANA PKWY EXT FROM CR532 TO N OF I-4/SR429 INTCHG

**District:** 08      **County:** 92 OSCEOLA

**Market Area:** 08      **Units:** English

**Contract Class:** 3      **Lump Sum Project:** N

**Design/Build:** N      **Project Length:** 4.000 MI

**Project Manager:** UNDERWOOD

**Version 12 Project Grand Total**

**\$1,273,562,069.39**

**Description:** Copy from V-11: Preferred Alternative: Poinciana Parkway Extension from CR 532 to N of I-4/SR 429 Interchange

**Project Sequences Subtotal** **\$841,925,335.14**

102-1	Maintenance of Traffic	10.00 %	\$84,192,533.51
101-1	Mobilization	10.00 %	\$92,611,786.86

**Project Sequences Total** **\$1,018,729,655.51**

Project Unknowns	25.00 %	\$254,682,413.88
Design/Build	0.00 %	\$0.00

**Non-Bid Components:**

Pay item	Description	Quantity	Unit	Unit Price	Extended Amount
999-25	INITIAL CONTINGENCY AMOUNT (DO NOT BID)		LS	\$150,000.00	\$150,000.00

**Project Non-Bid Subtotal** **\$150,000.00**

**Version 12 Project Grand Total** **\$1,273,562,069.39**